



Post Office Box 10279  
Wilmington, NC 28404-0279  
Telephone: (910) 452-5861  
Fax: (910) 452-7563

June 18, 2003

Commander  
Naval Facilities Engineering Command  
Atlantic Division  
1510 Gilbert Street  
Norfolk, Virginia 23511-6287

Attention: EV23JC, Mr. John D. Conway, P.G.

Re: **FINAL** Soil Assessment Report  
**PP-3332**  
Marine Corps Base  
Camp Lejeune, North Carolina

**Navy Contract No. N62470-01-D-3009**  
**Delivery Order No. 0054**  
**CATLIN Project No. 203-016**

Dear Mr. Conway:

CATLIN Engineers and Scientists (CATLIN) is pleased to submit the FINAL Soil Assessment Report document for the above referenced site. We have reviewed the comments to the referenced draft Soil Assessment Report and offer the following responses to the comments/concerns offered by Ms. Hall and Ms. Hakola.

**Soil Assessment Report**  
**PP-3332**  
**May 2, 2003**

**EMD Comments (6/13/2003)**

- 1. Title Page**
  - Insert "Box" between PSC and 20004 in address.**

Revised per comment.

## 2. Executive Summary

- **1<sup>st</sup> paragraph, 1<sup>st</sup> sentence – Delete “the” in front of “MCB”.**

Revised per comment.

- **1<sup>st</sup> paragraph – “.... Building PP-3332 is designated as ‘base housing’....” Note that this site is located in the Paradise Point Housing Area instead of simply base housing.**

Revised per comment.

- **3<sup>rd</sup> bullet – “Soil contamination was detected in the sidewalls...” This refers to the UST closure report, not the LSA or SAR. Suggest inserting this sentence after the first sentence of the second paragraph and ahead of the last sentence, “The subsequent investigations....”.**

Revised per comment.

- **3<sup>rd</sup> paragraph – Swap the second and third sentences (i.e. “Soils with contaminant concentrations....are proposed for excavation. Approximately 28 cubic yards ....”).**

Revised per comment.

- **3<sup>rd</sup> paragraph - Mention that this site is classified as “Low Risk” and “Residential”.**

The last sentence of this paragraph has been revised as requested.

## 3. Site History, Phase I LSA

- **1<sup>st</sup> bullet – Verify <920 figure.**

The concentration reported is correct.

- **2<sup>nd</sup> bullet – Concentration levels were also below STGW standards.**

Acknowledged, however our site is subject to the Residential MSCCs, we feel adding reference to the STGW MSCCs would add confusion.

## 4. Receptor Information

- **Item 6, 1<sup>st</sup> sentence – Insert “A” at beginning of sentence and delete space between “north” and “eastern”.**

Revised per comment.

**5. Soil Investigation/Historical Soil Sampling – UST Removal**

- **1<sup>st</sup> paragraph – Consistent with the following sections, include date and location (i.e. sidewalls of former UST tank basin) of soil sampling activities.**

Revised per comment.

**6. Soil Investigation/Historical Soil Sampling – Phase I LSA**

- **1<sup>st</sup> paragraph, last sentence – Add “except toluene and benzoic acid” at end of sentence.**

Revised per comment.

**7. Soil Investigation/Current Soil Sampling – Soil Assessment Report**

- **1<sup>st</sup> paragraph, second sentence – Soil samples should have delineated the horizontal and vertical extent of contamination. Discuss vertical extent.**

The sentence has been revised to read “...soil samples delineate the horizontal and vertical extent of the petroleum release....”.

- **1<sup>st</sup> paragraph, third sentence – Consider deleting “The” at beginning of sentence.**

Revised per comment.

- **1<sup>st</sup> paragraph, last sentence – This sentence is essentially repeated at the end of the next paragraph. Consider revising.**

This sentence has been deleted.

- **EPA 8270 – Is benzoic acid a petroleum related substance? (Just curious.)**

No. A cursory review of the Merck Index indicates that it is naturally occurring in berries and secreted by all vertebrates except fowl. It's uses include food preservation and a topical antifungal pharmaceutical.

- **MADEP VPH/EPH, 2<sup>nd</sup> paragraph, 1<sup>st</sup> sentence – Insert “investigation” after “SAR”.**

Revised per comment.

**8. Proposed Remedy for Soil Contamination**

- **Item 1, last sentence – Consider revising sentence.**

Sentence has been revised.

- **Item 4 – Soil excavation should be completed in six months provided funding is available. Note that the State will be notified regarding any delays or changes.**

Revised per comment.

- **Item 5, last paragraph – Insert comma after MCB and move EMD between I & E and EQB.**

Revised per comment.

**9. Table 6**

- **Insert “Box” in address.**

Revised per comment.

In preparation of this Final document, we have also incorporated the comments made to the Draft report for Site PP-3326.

CATLIN Engineers and Scientists appreciates the opportunity to continue to provide services to LANTDIV and the MCB on your environmental projects. We look forward to hearing from you soon.

Sincerely,



Michael E. Mason, P.E.  
CATLIN Program Manager



Shane A. Chasteen  
Project Scientist

Attachments: Final SAR

cc: Mr. Roger R. Marce, Jr. - Code AQ 135 Contracts (correspondence only)  
Commanding General, Attn: Director I&E/EMD/EQB (2 copies)

203016\_SAR\_final ltr

**SOIL ASSESSMENT REPORT**

**FOR**

**PP-3332**

**MARINE CORPS BASE  
CAMP LEJEUNE, NORTH CAROLINA**

**NC DENR UST INCIDENT NO. 24011  
RICK CLASSIFICATION: LOW RISK  
LAND USE CLASSIFICATION: RESIDENTIAL**

**JUNE 18, 2003**

**CONTRACT NO. N62470-01-D-3009  
DELIVERY ORDER NO. 0054  
CATLIN PROJECT NO. 203-016**



**PREPARED BY:**

**CATLIN ENGINEERS AND SCIENTISTS  
P. O. BOX 10279  
WILMINGTON, NORTH CAROLINA 28404-0279  
(910) 452-5861**

## **REPRODUCTIONS**

This report has been prepared on behalf of and exclusively for the use of LANTDIV. This report and findings contained herein shall not, in whole or in part, be disseminated or conveyed to any parties other than LANTDIV, or be used or relied upon by any other party, in whole or in part, without the prior written consent of LANTDIV and CATLIN Engineers and Scientists.

## TABLE OF CONTENTS

	<u>PAGE</u>
<b>LIST OF ACRONYMS</b>	<b>i</b>
<b>A. TITLE PAGE</b>	<b>1</b>
<b>B. EXECUTIVE SUMMARY</b>	<b>2</b>
<b>C. SITE HISTORY</b>	<b>3</b>
<b>D. RECEPTOR INFORMATION</b>	<b>4</b>
<b>1. WATER SUPPLY WELLS</b>	<b>4</b>
<b>2. PUBLIC WATER SUPPLIES</b>	<b>4</b>
<b>3. SURFACE WATER</b>	<b>4</b>
<b>4. WELLHEAD PROTECTION AREAS</b>	<b>4</b>
<b>5. DEEP AQUIFERS IN THE COASTAL PLAIN PHYSIOGRAPHIC REGION</b>	<b>4</b>
<b>6. SUBSURFACE STRUCTURES</b>	<b>5</b>
<b>7. PROPERTY OWNERS AND OCCUPANTS</b>	<b>5</b>
<b>E. SITE GEOLOGY</b>	<b>5</b>
<b>F. SOIL INVESTIGATION</b>	<b>6</b>
<b>G. CONCLUSIONS AND RECOMMENDATIONS</b>	<b>7</b>
<b>H. PROPOSED REMEDY FOR SOIL CONTAMINATION</b>	<b>8</b>
<b>1. EVALUATION OF REMEDIATION ALTERNATIVES</b>	<b>8</b>
<b>2. PROPOSED REMEDIATION</b>	<b>8</b>
<b>3. POST REMEDIATION SAMPLING</b>	<b>8</b>
<b>4. SCHEDULE</b>	<b>8</b>
<b>5. PUBLIC NOTICE</b>	<b>8</b>
<b>I. LIMITATIONS</b>	<b>9</b>
<b>J. REFERENCES</b>	<b>10</b>

## TABLES

TABLE 1	SITE HISTORY - UST SYSTEM INFORMATION
TABLE 2	SITE HISTORY - UST OWNER/OPERATOR INFORMATION
TABLE 3A	SUMMARY OF SOIL LABORATORY RESULTS – EPA METHOD 8260B/5035
TABLE 3B	SUMMARY OF SOIL LABORATORY RESULTS – EPA METHOD 8270
TABLE 3C	SUMMARY OF SOIL LABORATORY RESULTS – MADEP VPH/EPH
TABLE 3D	SUMMARY OF SOIL LABORATORY RESULTS – MADEP VPH/EPH AS COMPARED TO NCDENR MSCCs
TABLE 4	SUMMARY OF GROUNDWATER LABORATORY RESULTS (NOT USED)
TABLE 5	WATER SUPPLY WELL INFORMATION (NOT USED)
TABLE 6	PROPERTY OWNERS/OCCUPANTS
TABLE 7	WELL CONSTRUCTION INFORMATION (NOT USED)

## FIGURES

FIGURE 1	SITE LOCATION AND WATER SURVEY (NOT USED)
FIGURE 2	SITE LOCATION WITH PLACES OF PUBLIC ASSEMBLY
FIGURE 3	SITE PLAN WITH UTILITIES
FIGURE 4A	SITE PLAN WITH SOIL LABORATORY RESULTS – EPA METHOD 8260B/5035
FIGURE 4B	SITE PLAN WITH SOIL LABORATORY RESULTS – EPA METHOD 8270
FIGURE 4C	SITE PLAN WITH SOIL LABORATORY RESULTS – MADEP EPH/VPH AS COMPARED TO NCDENR MSCCs
FIGURE 5	SITE PLAN WITH GROUNDWATER LABORATORY RESULTS (NOT USED)
FIGURE 6A	CROSS-SECTION – PLAN VIEW
FIGURE 6B	CROSS-SECTION – A-A'
FIGURE 6C	CROSS-SECTION – B-B'

## APPENDICES

APPENDIX A	BORING LOGS
APPENDIX B	NORTH CAROLINA WELL CONSTRUCTION RECORDS (NOT USED)
APPENDIX C	FIELD MEASUREMENTS (NOT USED)
APPENDIX D	STANDARD PROCEDURES
APPENDIX E	LABORATORY REPORTS AND CHAIN-OF-CUSTODY DOCUMENTATION
APPENDIX F	UST CLOSURE SAMPLING RESULTS

## LIST OF ACRONYMS

2000 Guidelines	Groundwater Section Guidelines for Investigation and Remediation of Soil and Groundwater
2001 Guidelines	Guidelines for Assessment and Corrective Action, North Carolina Underground Storage Tank Section (Effective July 1, 2001)
2L GWQS	NCAC T15A:02L Groundwater Quality Standards
ARO	Asheville Regional Office
AS	Air Sparge
AST	Aboveground Storage Tank
BDL	Below Detection Limit
BN	Base/Neutral (extractables)
BNA	Base/Neutral/Acid (extractables)
BQL	Below Quantitation Limit
BLS	Below Land Surface
BTEX	Benzene, Toluene, Ethylbenzene, Xylenes
CAP	Corrective Action Plan
CATLIN	CATLIN Engineers and Scientists (Formerly RC&A)
CFR	Code of Federal Regulations
Cr	Chromium
CSA	Comprehensive Site Assessment
CNP	Carbon Nitrogen Phosphorous
CPT	Cone Penetrometer Test
DEM	Division of Environmental Management
DIPE	Diisopropyl Ether
DO	Dissolved Oxygen
DOD	Department of Defense
DPT	Direct Push Technology
DWQ	Division of Water Quality
DWM	Division of Waste Management
DTW	Depth to Water
EAD	Environmental Affairs Department
EDB	Ethylene di-bromide
EMD	Environmental Management Division
EPA	Environmental Protection Agency
EPH	Extractable Petroleum Hydrocarbons
EQB	Environmental Quality Branch
Fe	Iron
FID	Flame Ionization Detector
FOD	Foreign Object Debris
FRO	Fayetteville Regional Office
FT	Feet
GCL	Gross Contaminant Level
GIS	Geographic Information System
GPS	Global Positioning System

Guidelines Vol. I	Groundwater Section Guidelines for Investigation and Remediation of Soil and Groundwater, Volume I, Sources Other Than Petroleum Underground Storage Tanks (May 1998)
Guidelines Vol. II	Groundwater Section Guidelines for Investigation and Remediation of Soil and Groundwater, Volume II, Petroleum Underground Storage Tanks (January 2, 1998)
HDPE	High Density Polyethylene
I/C	Industrial/Commercial
ID	Identification
I&E	Installations and Environment Department
IGWQS	Interim Groundwater Quality Standards
IPE	Isopropyl Ether
LANTDIV	Atlantic Division
LSA	Limited Site Assessment
LUST	Leaking Underground Storage Tank
m-	meta
m	meter
MADEP	Massachusetts Department of Environmental Protection
MCALF	Marine Corps Auxiliary Landing Field
MCAS	Marine Corps Air Station
MCB	Marine Corps Base
MCOLF	Marine Corps Outlying Landing Field
MDL	Method Detection Limit
mg/Kg	Milligrams per Kilogram
mg/L	Milligrams per Litre
MRO	Mooresville Regional Office
MSCC	Maximum Soil Contaminant Concentration
MSL	Mean Sea Level
MTBE	Methyl tertiary butyl ether
µg/Kg	Micrograms per Kilogram
µg/L	Micrograms per Litre
NA	Not Analyzed
N/A	Not Applicable
NC	North Carolina
NCAC	North Carolina Administrative Code
NCDENR	North Carolina Department of Environment and Natural Resources
NCDOC	North Carolina Department of Corrections
NCDOT	North Carolina Department of Transportation
NCSP	North Carolina State Plane
NCSPA	North Carolina State Ports Authority
NE	None Established
NM	Not Measured
NMT	No Measurable Thickness
NS	Not Sampled
o-	ortho
OVA	Organic Vapor Analyzer
p-	para
PAH	Polynuclear Aromatic Hydrocarbons
Pb	Lead
PPB	Parts Per Billion
PPM	Parts Per Million

PID	Photo Ionization Detector
PQL	Practical Quantitation Limit
PVC	Polyvinyl chloride
RBCA	Risk-Based Corrective Action
RCRA	Resource Conservation and Recovery Act
Res	Residential
ROI	Radius of Influence
RRO	Raleigh Regional Office
SAR	Soil Assessment Report
SOW	Scope of Work
STGW	Soil-to-Groundwater
SVE	Soil Vapor Extraction
SVOC	Semi Volatile Organic Compound
TDHF	Toxicologically Defined Hydrocarbons Fractions
TCLP	Toxicity Characteristic Leaching Procedure
TIC	Tentatively Identified Compound
TKN	Total Kjeldahl Nitrogen
TOC	Top of Casing
TPH	Total Petroleum Hydrocarbons
US	United States
USCS	Unified Soil Classification System
USEPA	United States Environmental Protection Agency
USGS	United States Geological Survey
UST	Underground Storage Tank
VOC	Volatile Organic Compounds
VPH	Volatile Petroleum Hydrocarbons
WaRO	Washington Regional Office
WiRO	Wilmington Regional Office
WSRO	Winston-Salem Regional Office

# SOIL ASSESSMENT REPORT

## A. TITLE PAGE

DATE OF REPORT: June 18, 2003  
Facility ID: N/A UST Incident Number (if known): 24011  
Site Name: PP-3332  
Site Location: Paradise Point Housing Area, Marine Corps Base, Camp Lejeune  
Nearest City/Town: Jacksonville County: Onslow  
Risk Classification: Low Land Use Classification: Residential

UST Owner: Commanding General - MCB Camp Lejeune  
I&E/EMD/EQB  
Address: PSC Box 20004  
MCB Camp Lejeune, NC 28542 Phone: (910) 451-5068

UST Operator: Same as above  
Address: Same as above Phone: Same as above

Property Owner: Same as above  
Address: Same as above Phone: Same as above

Property Occupant: 1<sup>st</sup> LT. P.J. Cabrera  
Address: 3332 Onslow Drive Phone: Unknown

Consultant/Contractor: CATLIN Engineers and Scientists  
Address: 220 Old Dairy Road, Wilmington, North Carolina 28405 Phone: (910) 452-5861

### Release Information

Date Discovered: September 13, 2001  
Longitude: 77.3675 W Latitude: 34.6841 N

Estimated Quantity of Release: Unknown

Cause of Release: Unknown

### Source of Release (e.g. Piping/UST):

UST and/or associated piping is suspected

### Sizes and contents of UST system(s) from which the release occurred:

Non-regulated, non-commercial, 285-gallon fuel oil UST used for heating a single-family residence

I, Michael E. Mason a Professional Engineer Licensed Geologist (circle one) for CATLIN Engineers and Scientists, do certify that the information contained in this report is correct and accurate to the best of my knowledge.

(Please Affix Seal and Signature)

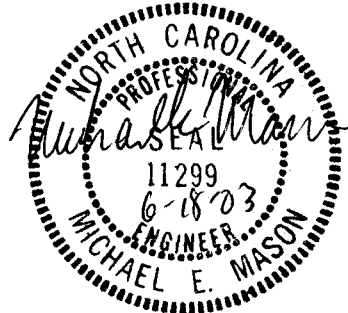

## **B. EXECUTIVE SUMMARY**

The project is located at building PP-3332 aboard MCB Camp Lejeune, North Carolina. Building PP-3332 is located in the Paradise Point Housing Area and was heated using fuel from a 285-gallon UST.

In September 2001, the UST was removed and as part of the closure reporting requirements, soil samples were collected and laboratory analyzed. Laboratory results indicated that the UST system had released hydrocarbons into the subsurface. Soil contamination was detected in the sidewalls of the former tank basin at levels in excess of the Residential Maximum Soil Contaminant Concentrations (MSCCs). The subsequent investigations (Phase I LSA and SAR) yielded the following findings:

- Free-product was not encountered in the subsurface of the site.
- Dissolved hydrocarbons were discovered within the groundwater at the site; however, no concentrations were detected in excess of any established Gross Contaminant Levels (GCLs).
- The extent of soil contamination has been delineated and appears to be limited to the immediate vicinity of the former tank basin to a depth of 3.5 feet below land surface.

Excavation of the contaminated soil is recommended based on the apparent limited extent of soil contamination. Soils with contaminant concentrations in excess of the Residential MSCCs are proposed for excavation. Approximately 28 cubic yards of soils are expected to require removal and disposal. As the site is classified as Residential and Low Risk, following soil excavation and verification of clean up, this site will meet the requirements for closure and No Further Action Status will be requested as part of a Soil Cleanup Report and Site Closure Request.

**C. SITE HISTORY**

*(Refer to Tables 1 and 2)*

The site previously contained one 285-gallon, non-regulated, non-commercial fuel oil UST. The fuel was used strictly for heating a single-family residence. The tank and associated product lines were closed by removal by J.A. Jones Environmental Services Company on September 13, 2001. UST history and owner information is included on Tables 1 and 2. The UST at this site was previously referred to as CC-3332 in the UST closure report, but is referred to as PP-3332 in this investigation.

Previous investigations at the site include a UST removal and tank closure performed by J.A. Jones and a Phase I LSA prepared by CATLIN.

<i>Underground Storage Tank Closure Report Marine Corps Base Building CC-3332, MCB Camp Lejeune, NC, January 23, 2002.</i>	J.A. Jones
<i>Leaking Underground Storage Tank (LUST) Phase I Limited Site Assessment Report for PP-3332, Marine Corps Base, Camp Lejeune, North Carolina, dated November 29, 2002</i>	CATLIN Engineers and Scientists

The results of these investigations indicate the following:

UST Removal/Closure

- The release or discharge from a petroleum underground storage tank (UST) system has impacted soils at the site.
- Laboratory analysis of the four sidewall soil samples collected at 4 feet BLS during UST Closure indicate concentration levels were found to be above Residential MSCCs for two parameters, the C<sub>9</sub>-C<sub>22</sub> Aromatics and 2-Methylnaphthalene.

Refer to Appendix F for UST Closure soil sampling results.

Phase I LSA

- Groundwater samples collected during the LSA activities did not exhibit contaminant concentrations in excess of established GCLs. Only the C<sub>9</sub>-C<sub>22</sub> Aromatics were detected at a concentration of <920 µg/L which is in excess of the IGWQS of 210 µg/L. There is no established GCL for the C<sub>9</sub>-C<sub>22</sub> Aromatics.
- Laboratory analysis of the soil sample collected during LSA activities indicate concentration levels were below Residential MSCCs.

LSA soil sample results are included on Tables 3A through 3D.

## **D. RECEPTOR INFORMATION**

The receptor information provided with the LSA remains unchanged as of the date of this report.

### **1. Water Supply Wells**

As documented in the LSA, there were no water supply wells located within 1,500 feet of subject site.

### **2. Public Water Supplies**

Public water is provided to buildings within 1,500 feet of the subject site by water mains which carry treated potable water. Potable water is supplied to the site and surrounding areas by the MCB water supply system. Potable water for the Paradise Point housing area is provided by the Hadnot Point Water Treatment Facility. Groundwater obtained from the Castle Hayne Aquifer beneath the MCB is the raw water source for the treatment facilities.

### **3. Surface Water**

The New River lies approximately 150 feet west of the subject site. Two unnamed, intermittent tidal creeks are located approximately 525 and 600 feet from the site.

### **4. Wellhead Protection Areas**

As discussed in the Phase I LSA, the site is not located in a proposed wellhead protection area.

### **5. Deep Aquifers in the Coastal Plain Physiographic Region**

As identified in the Geologic Map of North Carolina (North Carolina Department of Natural Resources and Community Development (1985)), the subject site lies within the Coastal Plain Physiographic Province. Potential impacts to deeper aquifers are unknown, though; minimal impact to surficial groundwater was revealed.

To some degree seven of the ten aquifers identified to date in the North Carolina Coastal Plain are typically present beneath portions of the MCB. In order of increasing depth, these aquifers include the Surficial, Castle Hayne, Beaufort, Peedee, Black Creek, and upper and lower Cape Fear aquifers.

Aquifers below the surficial aquifer in the area of Paradise Point typically include the Castle Hayne Aquifer, the Beaufort Aquifer, and the Peedee Aquifer, in order of increasing depth. Both the Beaufort and Peedee Aquifers contain saltwater in portions of the MCB and are not generally used for water supply. The Castle Hayne Aquifer contains freshwater and is the principal aquifer used in the area for water supply.

**6. Subsurface Structures**

*(Refer to Figure 3)*

A municipal sanitary sewer line enters the residence on the northeastern side of the residence, north of the source area. Underground power, cable and telephone enter the residence to the south of the source area. Due to the shallow depth of these utilities and the depth and limited nature of known contamination, it is not deemed likely that these utilities would serve as preferential pathways for contaminant migration. Known utilities are illustrated on Figure 3.

**7. Property Owners and Occupants**

*(Refer to Table 6)*

Refer to Table 6 for a list of property owners/occupants.

**E. SITE GEOLOGY**

According to the Geologic Map of North Carolina (North Carolina Department of Natural Resources and Community Development (1985)) the site lies within the Coastal Plain Physiographic Province.

Field observations noted during hand auger soil boring advancement (as part of the Phase I LSA) indicates site geology to be comprised of very fine silty sand to a depth of four feet below land surface. Split spoon samples collected during temporary monitoring well USTPP3332-TW01 boring advancement revealed fine to very fine silty sands to 5-7 feet below land surface and fine to very fine silty/sandy clay to 10-12 feet below land surface. Boring logs for the soil boring and temporary well are included in Appendix A.

Hand augered borings for this investigation indicate fine grained, silty sand to boring termination at 3.5 feet BLS. Boring logs for borings USTPP3332-SB02 through USTPP3332-SB04 are included in Appendix A. Geologic cross-sections of the study site have been prepared and are shown on Figures 6A through 6C.

The split spoons collected during advancement of the temporary monitoring well boring revealed soils to be saturated at approximately six feet below land surface. Groundwater depth as measured in the monitoring well in July 2002 was 5.8 feet below the top of the well casing. Groundwater depth was estimated at 3.5 feet BLS during this investigation (March 2003)

Subsurface soils in the water bearing zone were described as silty sands and clays, which typically exhibit low permeability. Based on experience with similar sites, rapid migration of groundwater contamination is not expected.

Due to the low contaminant concentrations observed, attenuation is expected due to adsorption and dispersion.

## **F. SOIL INVESTIGATION**

*(Refer to Tables 3A-3D, Figures 4A-4C, and Appendices D, E, and F)*

### Historical Soil Sampling – UST Removal

During UST removal procedures, soil samples were obtained in November 2001 from the sidewalls and base of the former tank basin. Laboratory analysis of samples CC3332-1 through CC3332-4 (sidewall samples) revealed concentrations of C<sub>9</sub>-C<sub>22</sub> aromatics and 2-Methylnaphthalene above the Residential MSCCs. The C<sub>9</sub>-C<sub>22</sub> Aromatics fraction was detected in the samples at concentrations ranging from 1,640 to 3,900 mg/Kg, which are in excess of the Residential MSCC of 469 mg/Kg. Also 2-Methylnaphthalene was detected in two of the samples at concentrations of 120 mg/Kg and 110 mg/Kg. The Residential MSCC for this compound is 63 mg/Kg. Refer to Appendix F for Historical Laboratory Data.

These results triggered the regulatory requirement for a Phase I LSA.

### Historical Soil Sampling – Phase I LSA

CATLIN personnel conducted soil sampling activities on July 22, 2002. Utilizing hand auger techniques, one soil boring (USTPP3332-SB01) was advanced to a depth of four feet BLS. This boring was advanced in the location of the former product feed line. Only one line sample was collected since the product line was less than five feet in length. The soil sample collected from three to four feet BLS in this boring was chosen for laboratory analysis. No contaminants were detected above the laboratory practical quantitation limits except toluene and benzoic acid.

It should be noted that a soil sample was not collected for laboratory analysis from the monitoring well boring installed in the former UST basin (USTPP3332-TW01), since the basin was backfilled with clean soil from the surface down into the surficial aquifer. Therefore, an undisturbed, vadose zone soil sample could not be collected within the former UST basin.

### Current Soil Sampling – Soil Assessment Report

On March 24, 2003, CATLIN personnel conducted a soil sampling event at the site as proposed in the Phase I LSA. It was intended that the collected soil samples delineate the horizontal and vertical extent of the petroleum release within the soils of the study area. Three soil borings were advanced to the water table utilizing hand auger technologies at the locations indicated on Figures 4A through 4C. At the time of the sampling event, the water table was noted at 3.5 feet BLS. Due to the seasonal high water table fluctuation, the soil samples were collected from 1-2 feet BLS for laboratory analysis. The soil samples were identified in the field and labeled on the chain of custody as USTPP3332-SB02 (1-2), USTPP3332-SB03 (1-2), and USTPP3332-SB04 (1-2).

All sampling was conducted in accordance with CATLIN's Standard Procedures included in Appendix D. The soil borings were immediately abandoned with cuttings following the collection of the samples. The soil samples were placed in laboratory glassware, labeled,

placed immediately on ice in a cooler, and transported under proper chain of custody protocol to Paradigm Analytical Laboratories, Inc. in Wilmington, North Carolina. The laboratory reports and chain of custody documentation are provided in Appendix E and are summarized as follows:

EPA Method 8260B/5035 (includes DIPE +MTBE)

As indicated in Table 3A and illustrated in Figure 4A, there were no EPA Method 8260B/5035 target compounds detected in the soil samples collected on March 24, 2003 at concentrations above the laboratory PQLs

EPA Method 8270

As indicated in Table 3B and illustrated in Figure 4B, benzoic acid was detected in all three soil samples collected on March 24, 2003. All concentrations detected were well below the Residential MSCC of 62,571 mg/kg. No other target compounds were detected in the soil samples collected on March 24, 2003 at concentrations above the laboratory PQLs.

MADEP VPH/EPH

As indicated in Tables 3C and 3D and illustrated in Figure 4C, there were no MADEP Aliphatic or Aromatic hydrocarbon fractions detected in the soil samples collected on March 24, 2003 above the laboratory PQLs.

Based on the results of the soil samples collected during this SAR investigation, it appears that vadose zone soil contamination has been delineated both horizontally and vertically. From the hand augered borings performed as part of this investigation, saturated soils were detected at 3.5 feet BLS, indicating that the seasonal high water table may be as shallow as 3.5 feet. Previous "dirty" samples were collected at the tank closure from 4 feet BLS, which may not be indicative of vadose zone soils. However, since they are "dirty" at 4 feet BLS, it is reasonable to assume that soil contamination may exist above 4 feet BLS in the vadose zone along the side walls of the former tank basin. Therefore, remediation of contaminated soils to the Residential MSCCs is recommended at this site.

**G. CONCLUSIONS AND RECOMMENDATIONS**

Based on the findings of this Soil Assessment Report, the levels of the hydrocarbons within the soils of the study area have been delineated. Soil contamination is reasonably assumed to exist in limited areas adjacent to the sidewalls of the former tank basin. It is recommended that these contaminated soils be remediated to the Residential MSCCs. Following soil remediation, the site will meet the requirements for closure and No Further Action Status will be requested as part of a Soil Cleanup Report and Site Closure Request.

## H. PROPOSED REMEDY FOR SOIL CONTAMINATION

### 1. Evaluation of Remediation Alternatives

Based on the limited horizontal and vertical extents of suspected soil contamination at this site, it appears that soil excavation would be the most economical remediation method. Further evaluation of remediation alternatives was not deemed necessary. The soil contamination appears limited to the sidewalls of the former tank basin from the land surface to approximately 3.5 feet BLS (the tank basin was backfilled with clean fill). It is proposed to clean up soils to the Residential MSCCs.

### 2. Proposed Remediation

An over-excavation of the walls of the former tank basin is proposed to eliminate the suspected remaining soil contamination on site. The estimated volume of soil to be removed assumes a 5 foot wide excavation around the former tank basin to a minimum depth of 3.5 feet BLS. The final dimensions of the tank excavation were 6.5 feet long by 5 feet wide by 5.5 feet deep. The estimated volume of soils to be removed is 28 cubic yards. The soils are proposed to be disposed off-Base at a State-approved disposal site.

### 3. Post Remediation Sampling

Confirmatory soil samples will be collected from the four sidewalls of the excavation after removal of the contaminated soils. Four samples are proposed (one from each side wall), each to be laboratory analyzed per the following methods:

<u>Method</u>	<u>Description</u>
8260	Volatile Organics + IPE + MTBE
8270	Base/Neutrals/Acid Extractables + TICS
VPH	MADEP
EPH	MADEP

### 4. Schedule

The soil excavation is expected to be completed within the next six months provided funding is available. The State will be notified regarding any delays or changes.

### 5. Public Notice

Public notice is required by the NCDENR if the responsible party proposes cleanup of soil contamination to an alternate standard (other than the lower of the Residential or Soil-to-Groundwater MSCC). As we are proposing cleanup to the Residential MSCC, public notice is required. The following parties are required to be notified:

- the local health director;
- the chief administrative officer of each political jurisdiction in which the

- contamination occurs; and
- all property owners and occupants contiguous to the area containing the contamination.

Public notification will be provided by the MCB, Camp Lejeune, Installations and Environment Department, Environmental Management Division, Environmental Quality Branch.

## **I. LIMITATIONS**

The soil and groundwater samples analyzed as part of this investigation only provide isolated data points and may not represent conditions at every location in the project area. Analyses and conclusions of this report, being based on interpolation between data points at the project area, may not be completely representative of all site conditions. Conclusions and recommendations of this investigation and report are based on the best available data in an effort to comply with current regulatory requirements.

## J. REFERENCES

- Cardinell, A.P. and Others, 1993, *Hydrogeologic Framework of U.S. Marine Corps Base at Camp Lejeune, North Carolina; U.S. Geological Survey Water-Resources Investigation Report 93-4049*: U.S. Geological Survey, Raleigh, North Carolina.
- CATLIN Engineers and Scientists, *Leaking Underground Storage Tank (LUST) Phase I Limited Site Assessment Report for PP-3332, Marine Corps Base, Camp Lejeune, North Carolina*, November 29, 2002.
- J.A. Jones Environmental Services Inc., *Underground Storage Tank Closure, UST No. CC-3332 Camp Lejeune, North Carolina*, January 23, 2002.
- North Carolina Department of Environment and Natural Resources, *Guidelines for Assessment and Corrective Action, North Carolina Underground Storage Tank Section* (Effective July 1, 2001).
- Stuckey, J.L., 1965, *North Carolina- It's Geology and Mineral Resources*, Raleigh, North Carolina: Department of Conservation and Development, 550 p.
- Winner, M.D., Jr., and Coble, R.W., 1989, *Hydrogeologic Framework of the North Carolina Coastal Plain Aquifer System: U.S. Geological Survey Open-File Report 87-690*, 155 p.

## **TABLES**

**TABLE 1**  
**SITE HISTORY**  
**UST SYSTEM INFORMATION**  
**UST PP-3332**

<b>UST ID Number</b>	<b>Product</b> (gasoline, diesel, jet fuel, etc.)	<b>Capacity</b> (gallons)	<b>Date Installed</b> (m/dd/yy)	<b>Date Permanently Closed (P), or Still in Use* (C)</b> (m/dd/yy)	<b>Was Release Associated With UST System?</b> (Yes / No)
PP-3332	Fuel Oil <sup>+</sup>	285	Unknown	(P) 9/13/01	Yes

\* UST was used strictly for residential heating purposes

\* Still in use means not permanently closed.

**TABLE 2**  
**SITE HISTORY**  
**UST OWNER/OPERATOR INFORMATION**  
**UST PP-3332**

UST ID Number	Name of Owner or Operator	Dates of Ownership/Operation (m/dd/yy) to (m/dd/yy)	Owner or Operator?
PP-3332	Commanding General Marine Corps Base Camp Lejeune, NC	Unknown to 9/13/01	Owner and Operator
Address		Telephone Number	
I&E/EMD/EQB PSC Box 20004 Marine Corps Base, Camp Lejeune, NC 28542		910-451-5068	

**TABLE 3A SUMMARY OF SOIL LABORATORY RESULTS**

Date: March 24, 2003

Incident Number and Name: 24011 - PP-3332

Facility ID#: N/A

**Analytical Method: EPA Method 8260B/5035**

Sample ID	Contaminant of Concern		Toluene	All Other Target Analytes
	Date Collected	Sample Depth (ft. BGS)		
<b>Residential MSCC (mg/kg)</b> <b>Industrial/Commercial MSCC (mg/kg)</b> <b>Soil to Groundwater MSCC (mg/kg)</b>			3,200 82,000 7	Varies Varies Varies
USTPP3332-SB01 (3-4)	7/22/02	3 - 4	0.0058	BQL
USTPP3332-SB02 (1-2)	3/24/03	1-2	<0.0061	BQL
USTPP3332-SB03 (1-2)	3/24/03	1-2	<0.0056	BQL
USTPP3332-SB04 (1-2)	3/24/03	1-2	<0.0054	BQL
USTPP3332-SB04D (1-2)	3/24/03	1-2	<0.0054	BQL

All results in mg/kg.

**TABLE 3B SUMMARY OF SOIL LABORATORY RESULTS**

Date: March 24, 2003

Incident Number and Name: 24011 - PP-3332

Facility ID#: N/A

**Analytical Method: EPA Method 8270**

Sample ID	Contaminant of Concern		Benzoic Acid	All Other Target Analytes
	Date Collected	Sample Depth (ft. BGS)		
Residential MSCC (mg/kg) Industrial/Commercial MSCC (mg/kg) Soil to Groundwater MSCC (mg/kg)			62,571 1,635,200 112	Varies Varies Varies
USTPP3332-SB01 (3-4)	7/22/02	3 - 4	7.1	BQL
USTPP3332-SB02 (1-2)	3/24/03	1-2	0.64 J	BQL
USTPP3332-SB03 (1-2)	3/24/03	1-2	0.38 J	BQL
USTPP3332-SB04 (1-2)	3/24/03	1-2	0.61 J	BQL

All results in mg/kg.

J = Detected below the quantitation limit.

**TABLE 3C SUMMARY OF SOIL LABORATORY RESULTS**

Date: March 24, 2003

Incident Number and Name: 24011 - PP-3332

Facility ID#: N/A

**Analytical Method: MADEP VPH/EPH**

Sample ID	Contaminant of Concern →		C9-C18 Aliphatics	C19-C36 Aliphatics	C11-C22 Aromatics	C5-C8 Aliphatics	C9-C12 Aliphatics	C9-C10 Aromatics
	Date Collected	Sample Depth (ft. BGS)						
USTPP3332-SB01 (3-4)	7/22/02	3 - 4	<10	<10	<10	<10	<10	<10
USTPP3332-SB02 (1-2)	3/24/03	1-2	<10	<10	<10	<10	<10	<10
USTPP3332-SB03 (1-2)	3/24/03	1-2	<10	<10	<10	<10	<10	<10
USTPP3332-SB04 (1-2)	3/24/03	1-2	<10	<10	<10	<10	<10	<10

All results in mg/kg.

**TABLE 3D SUMMARY OF SOIL LABORATORY RESULTS**

Date: March 24, 2003

Incident Number and Name: 24011 - PP-3332

Facility ID#: N/A

**Analytical Method: MADEP VPH/EPH AS COMPARED TO NCDENR MSCCs**

Sample ID	Contaminant of Concern →		C5-C8 Aliphatics	C9-C18 Aliphatics	C19-C36 Aliphatics	C9-C22 Aromatics
	Date Collected	Sample Depth (ft. BGS)				
Residential MSCC (mg/kg)			939	9,386	93,860	469
Industrial/Commercial MSCC (mg/kg)			24,528	245,280	#	12,264
Soil to Groundwater MSCC (mg/kg)			72	3,255	##	34
USTPP3332-SB01 (3-4)	7/22/02	3 - 4	<10	<20	<10	<20
USTPP3332-SB02 (1-2)	3/24/03	1-2	<10	<20	<10	<20
USTPP3332-SB03 (1-2)	3/24/03	1-2	<10	<20	<10	<20
USTPP3332-SB04 (1-2)	3/24/03	1-2	<10	<20	<10	<20

# Health based level &gt;100%

## Considered immobile

All results in mg/kg.

**TABLE 6**

**PROPERTY OWNERS/OCCUPANTS**

Date: March-03

Incident No. and Name: 24011 - PP-3332

Facility ID#: N/A

<b>Tax Parcel Number/Map ID</b>	<b>Owner/Occupant Name</b>	<b>Address</b>
N/A	Owner: Commanding General, MCB Camp Lejeune	I&E/EMD/EQB PSC Box 20004 Marine Corps Base, Camp Lejeune, NC 28542
N/A	Occupant: 1st LT P.J. Cabrera	3332 Onslow Drive Marine Corps Base, Camp Lejeune, NC 28542

## FIGURES

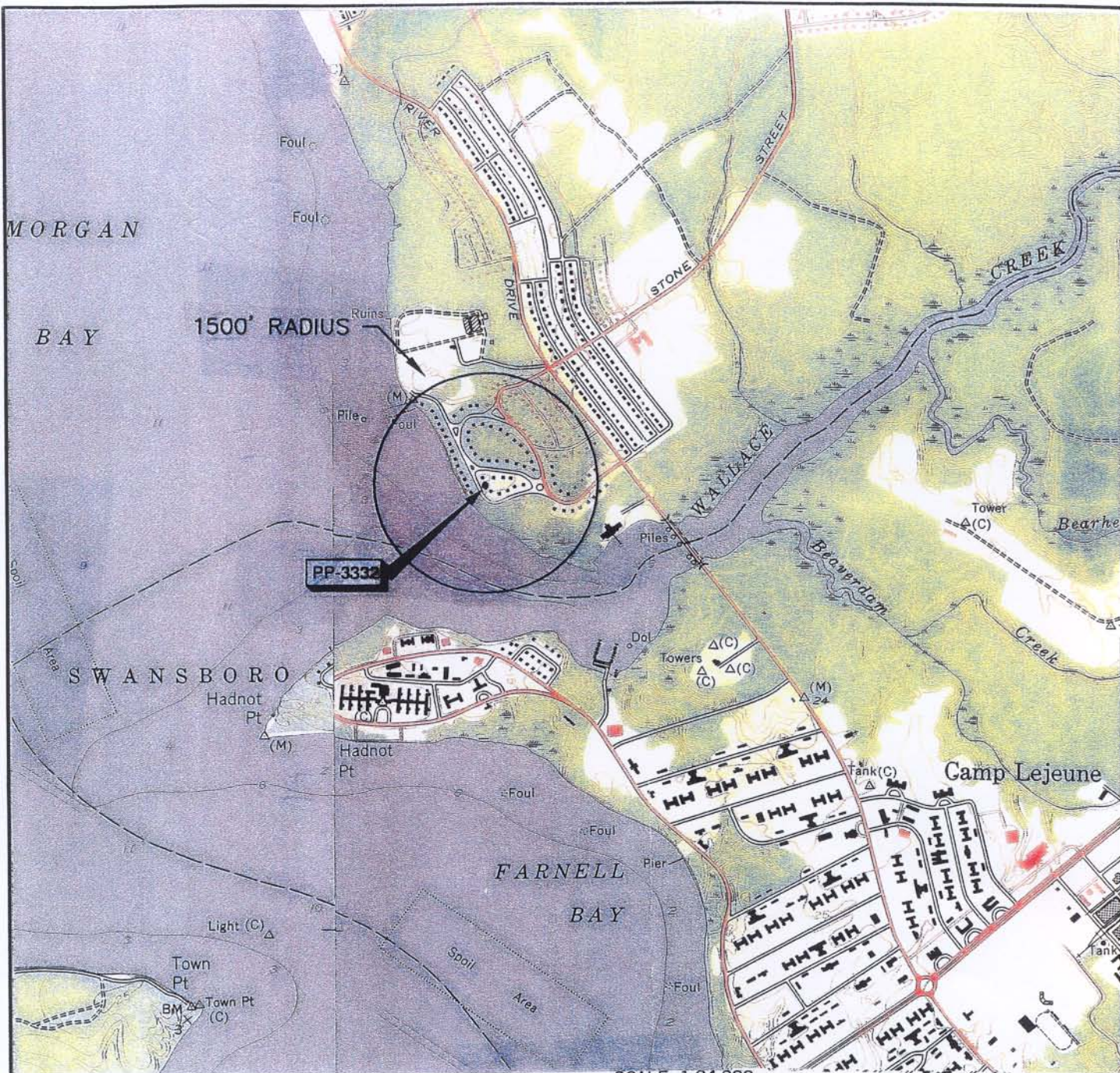

SCALE 1:24 000

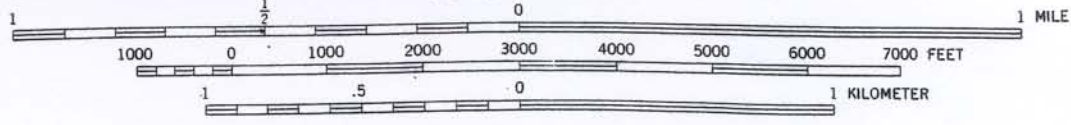

CAMP LEJEUNE, N. C.

N 3437.5—W 7715/7.5

1952  
PHOTOREVISED 1971

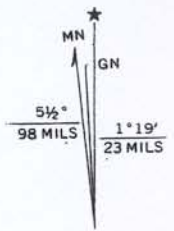

UTM GRID AND 1971 MAGNETIC NORTH DECLINATION AT CENTER OF SHEET

NOTE:  
NO PLACES OF PUBLIC ASSEMBLY IDENTIFIED WITHIN A 1,500' RADIUS OF THE SUBJECT SITE

<p>WILMINGTON, NORTH CAROLINA</p>	<p>PROJECT</p> <p>PP-3332 MARINE CORPS BASE CAMP LEJEUNE, N. C.</p>	<p>TITLE</p> <p>SITE LOCATION WITH PLACES OF PUBLIC ASSEMBLY</p>	<p>FIGURE</p> <p>2</p>
	<p>JOB NO: 202044-02</p>	<p>DATE: SEP 2002</p>	<p>SCALE: 1"=10'</p>

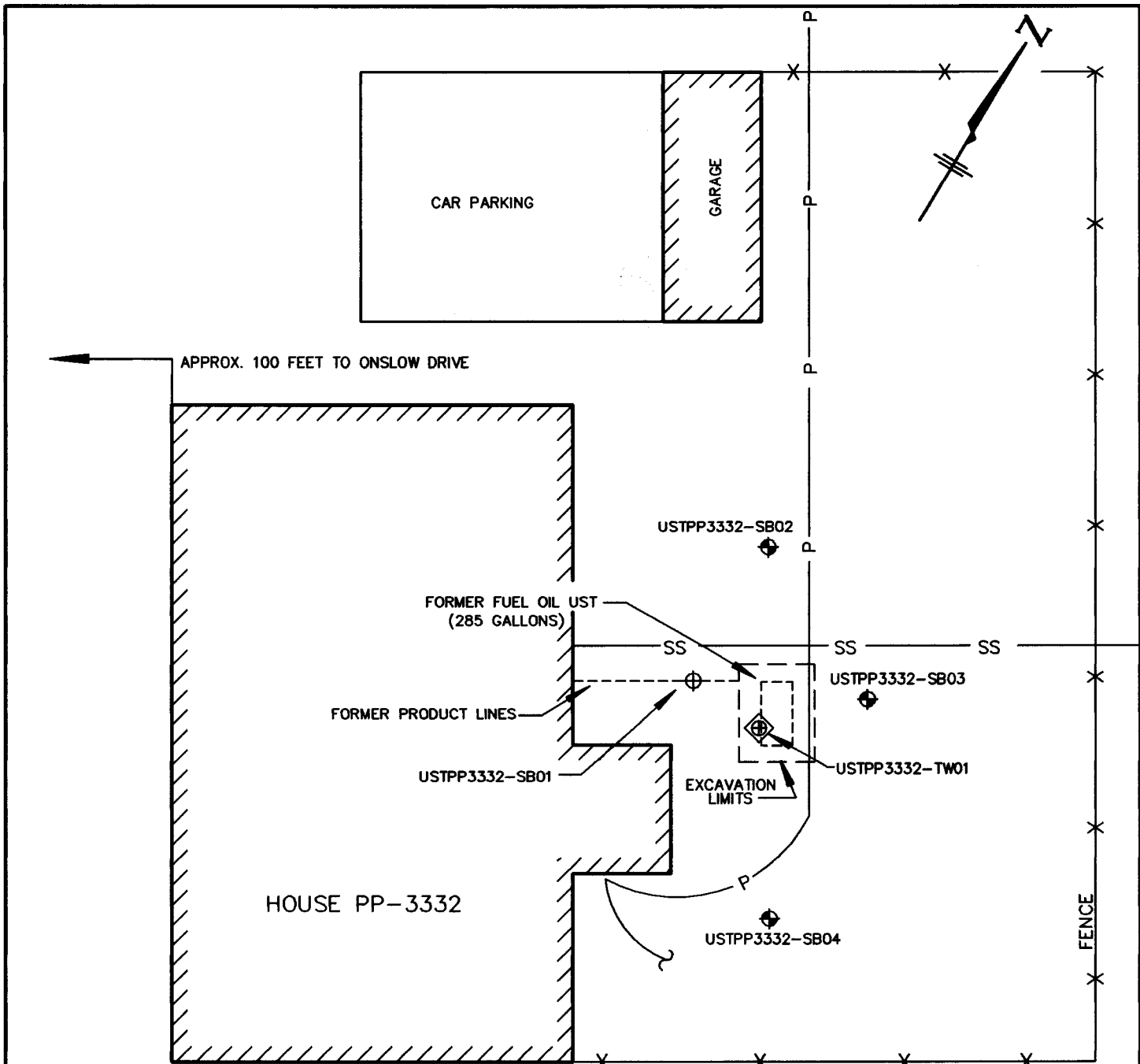

LEGEND

EXISTING	NEW	DESCRIPTION
		BUILDING
		SOIL BORING (HAND AUGER)
		TYPE II WELL (TEMPORARY)
— P —		POWER LINE
— SS —		SANITARY SEWER



NOTE:

1. MAP ADAPTED FROM J.A. JONES

 WILMINGTON, NORTH CAROLINA	PROJECT PP-3332 MARINE CORPS BASE CAMP LEJEUNE, N.C.	TITLE SITE PLAN WITH UTILITIES	FIGURE 3
	JOB NO: 203016-41    DATE: MAY 2003	SCALE: 1"=10'	DRAWN BY: WHW    CHECKED BY: MEM

Analytical Method: EPA Method 8260B/5035

Sample ID	Contaminant of Concern →		Toluene	All Other Target Analytes
	Date Collected	Sample Depth (ft. BGS)		
Residential MSCC (mg/kg)			3,200	Varies
Industrial/Commercial MSCC (mg/kg)			82,000	Varies
Soil to Groundwater MSCC (mg/kg)			7	Varies
USTPP3331-SB01 (3-4)	7/22/02	3 - 4	0.0058	BQL
USTPP3332-SB02 (1-2)	3/24/03	1-2	<0.0061	BQL
USTPP3332-SB03 (1-2)	3/24/03	1-2	<0.0056	BQL
USTPP3332-SB04 (1-2)	3/24/03	1-2	<0.0054	BQL
USTPP3332-SB04D (1-2)	3/24/03	1-2	<0.0054	BQL

All results in mg/kg.

CAR PARKING

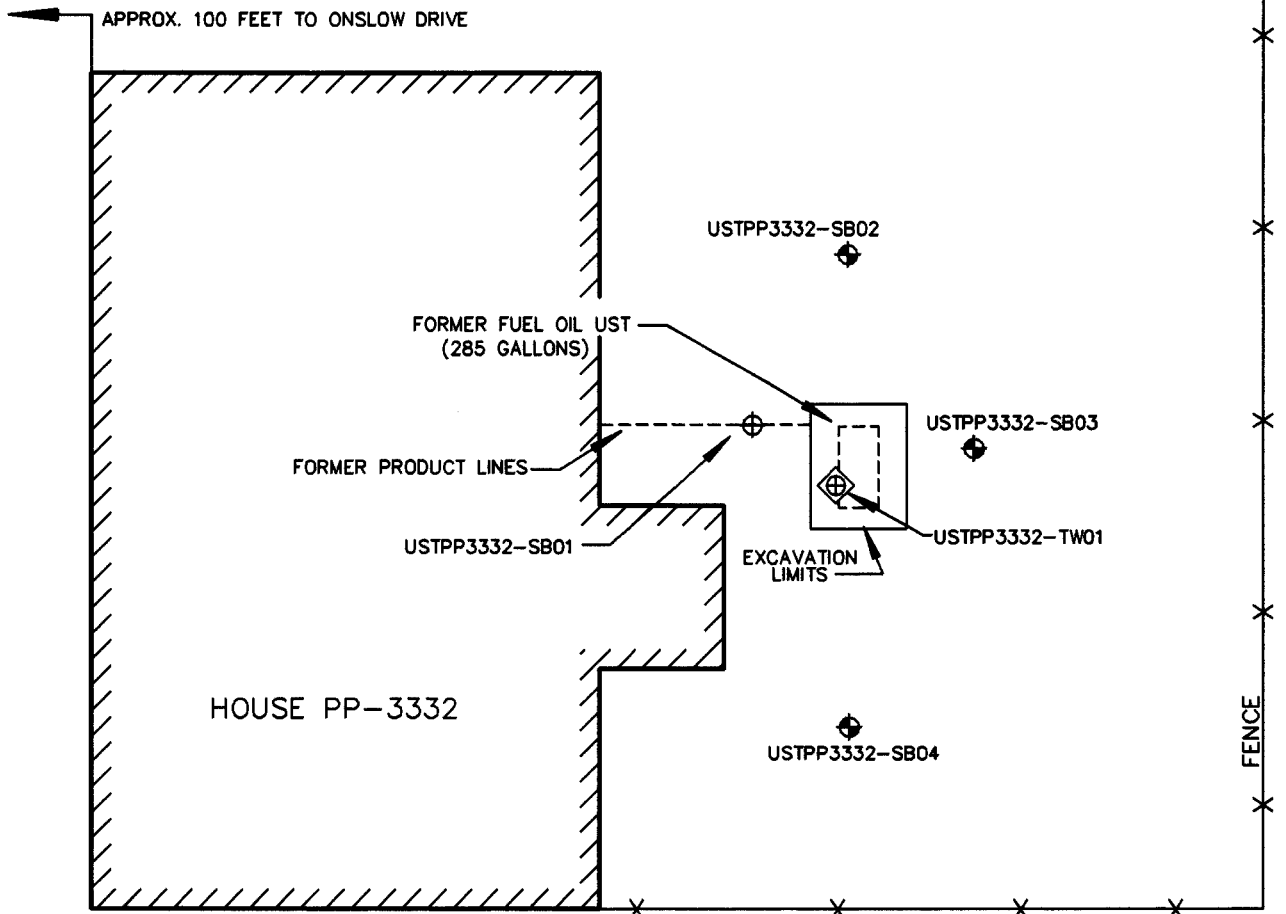
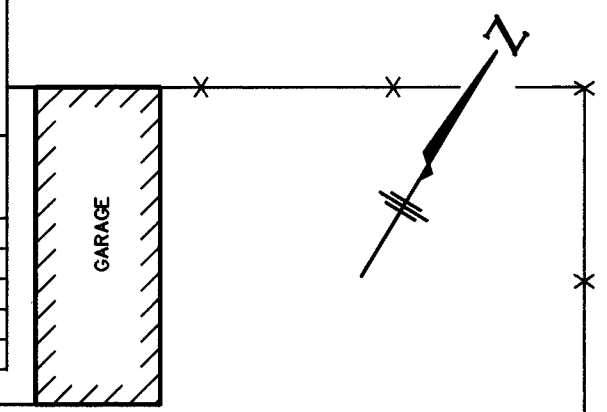

LEGEND

EXISTING	NEW	DESCRIPTION
		BUILDING
		SOIL BORING (HAND AUGER)
		TYPE II WELL (TEMPORARY)



NOTE:

1. MAP ADAPTED FROM J.A. JONES

 WILMINGTON, NORTH CAROLINA	PROJECT PP-3332 MARINE CORPS BASE CAMP LEJEUNE, N.C.	TITLE SITE PLAN WITH SOIL LABORATORY RESULTS -EPA METHOD 8260B/5035	FIGURE 4A
	JOB NO: 203016-41	DATE: MAY 2003	SCALE: 1"=10' DRAWN BY: WHW CHECKED BY: MEM

Analytical Method: EPA Method 8270

Sample ID	Contaminant of Concern		Benzoic Acid	All Other Target Analytes
	Date Collected	Sample Depth (ft. BGS)		
Residential MSCC (mg/kg)			62,571	Varies
Industrial/Commercial MSCC (mg/kg)			1,635,200	Varies
Soil to Groundwater MSCC (mg/kg)			112	Varies
USTPP3332-SB01 (3-4)	7/22/02	3 - 4	7.1	BQL
USTPP3332-SB02 (1-2)	3/24/03	1-2	0.64 J	BQL
USTPP3332-SB03 (1-2)	3/24/03	1-2	0.38 J	BQL
USTPP3332-SB04 (1-2)	3/24/03	1-2	0.61 J	BQL

All results in mg/kg.

J = Detected below the quantitation limit.

CAR PARKING

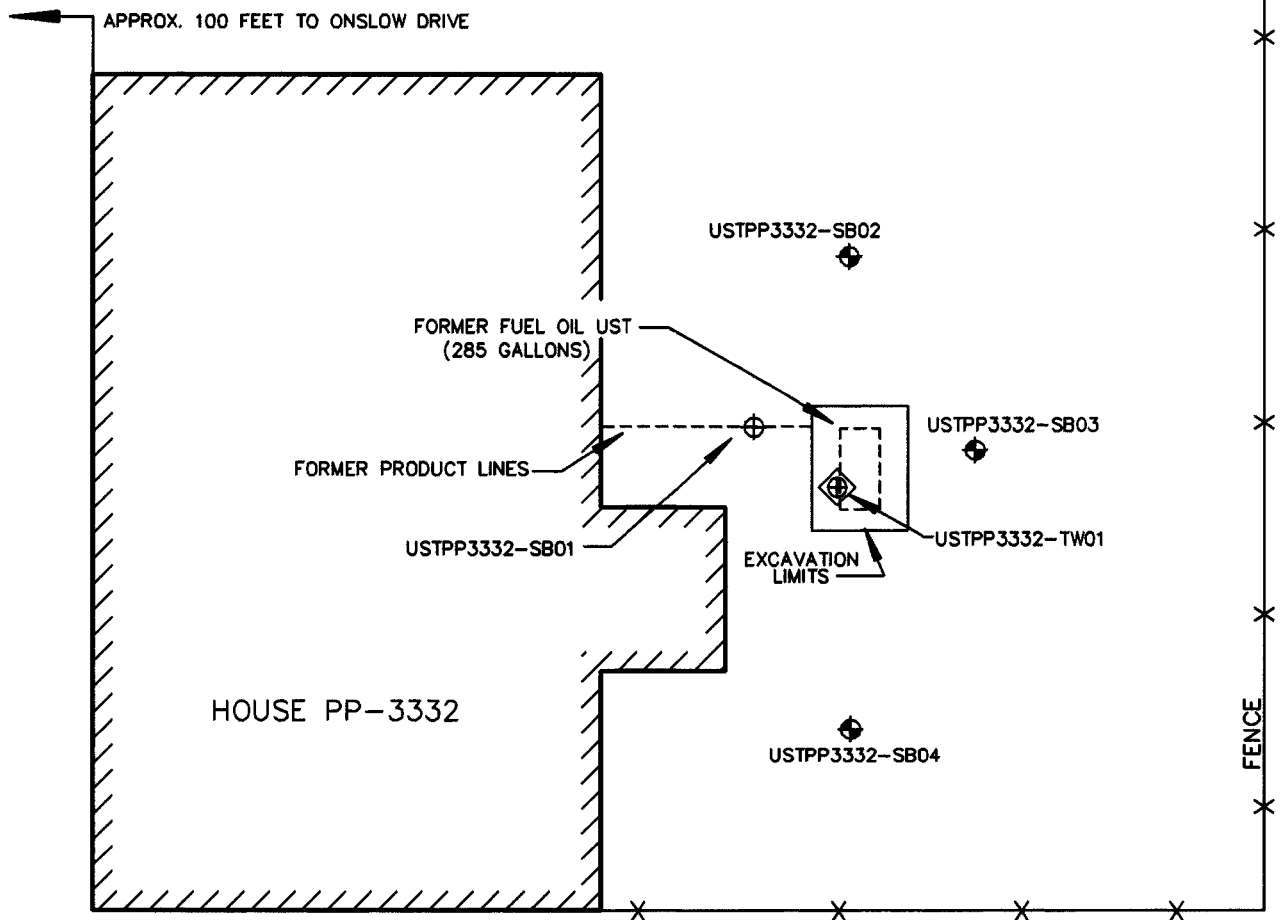
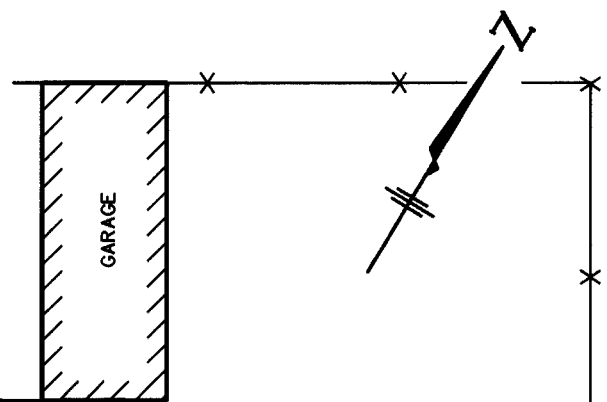

LEGEND

EXISTING	NEW	DESCRIPTION
		BUILDING
		SOIL BORING (HAND AUGER)
		TYPE II WELL (TEMPORARY)



NOTE:

1. MAP ADAPTED FROM J.A. JONES

 WILMINGTON, NORTH CAROLINA	PROJECT PP-3332 MARINE CORPS BASE CAMP LEJEUNE, N.C.	TITLE SITE PLAN WITH SOIL LABORATORY RESULTS -EPA METHOD 8270	FIGURE 4B
	JOB NO: 203016-41	DATE: MAY 2003	SCALE: 1"=10' DRAWN BY: WHW CHECKED BY: MEM

Analytical Method: MADEP VPH/EPH AS COMPARED TO NCDENR MSCCs

Sample ID	Contaminant of Concern →		C5-C8 Aliphatics	C9-C18 Aliphatics	C19-C36 Aliphatics	C9-C22 Aromatics
	Date Collected	Sample Depth (ft. BGS)				
Residential MSCC (mg/kg)			939	9,386	93,860	469
Industrial/Commercial MSCC (mg/kg)			24,528	245,280	#	12,264
Soil to Groundwater MSCC (mg/kg)			72	3,255	##	34
USTPP3332-SB01 (3-4)	7/22/02	3 - 4	<10	<20	<10	<20
USTPP3332-SB02 (1-2)	3/24/03	1-2	<10	<20	<10	<20
USTPP3332-SB03 (1-2)	3/24/03	1-2	<10	<20	<10	<20
USTPP3332-SB04 (1-2)	3/24/03	1-2	<10	<20	<10	<20

# Health based level >100%  
## Considered immobile  
All results in mg/kg.

CAR PARKING

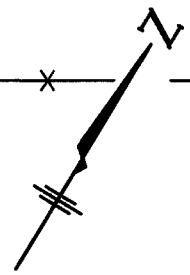
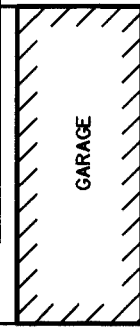

APPROX. 100 FEET TO ONSLOW DRIVE

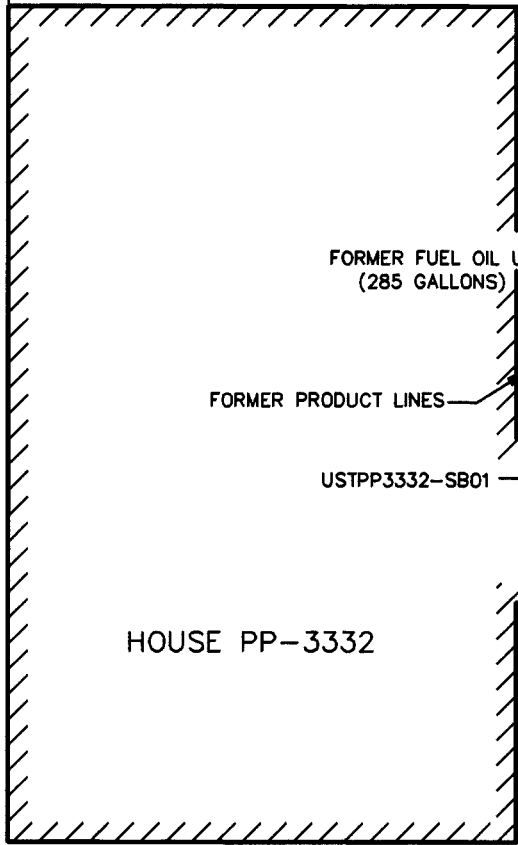

USTPP3332-SB02

FORMER FUEL OIL UST  
(285 GALLONS)

FORMER PRODUCT LINES

USTPP3332-SB01

EXCAVATION LIMITS

USTPP3332-SB03

USTPP3332-TW01

HOUSE PP-3332

USTPP3332-SB04

FENCE

LEGEND

EXISTING	NEW	DESCRIPTION
		BUILDING
		SOIL BORING (HAND AUGER)
		TYPE II WELL (TEMPORARY)

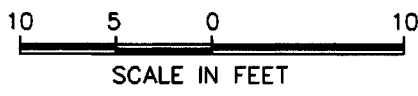

NOTE:  
1. MAP ADAPTED FROM J.A. JONES

 WILMINGTON, NORTH CAROLINA	PROJECT PP-3332 MARINE CORPS BASE CAMP LEJEUNE, N.C.	TITLE SITE PLAN WITH SOIL LABORATORY RESULTS -MADEP EPH/VPH AS COMPARED TO NCDENR MSCCs	FIGURE 4C
	JOB NO: 203016-41    DATE: MAY 2003	SCALE: 1"=10'	DRAIN BY: WHW    CHECKED BY: MEM

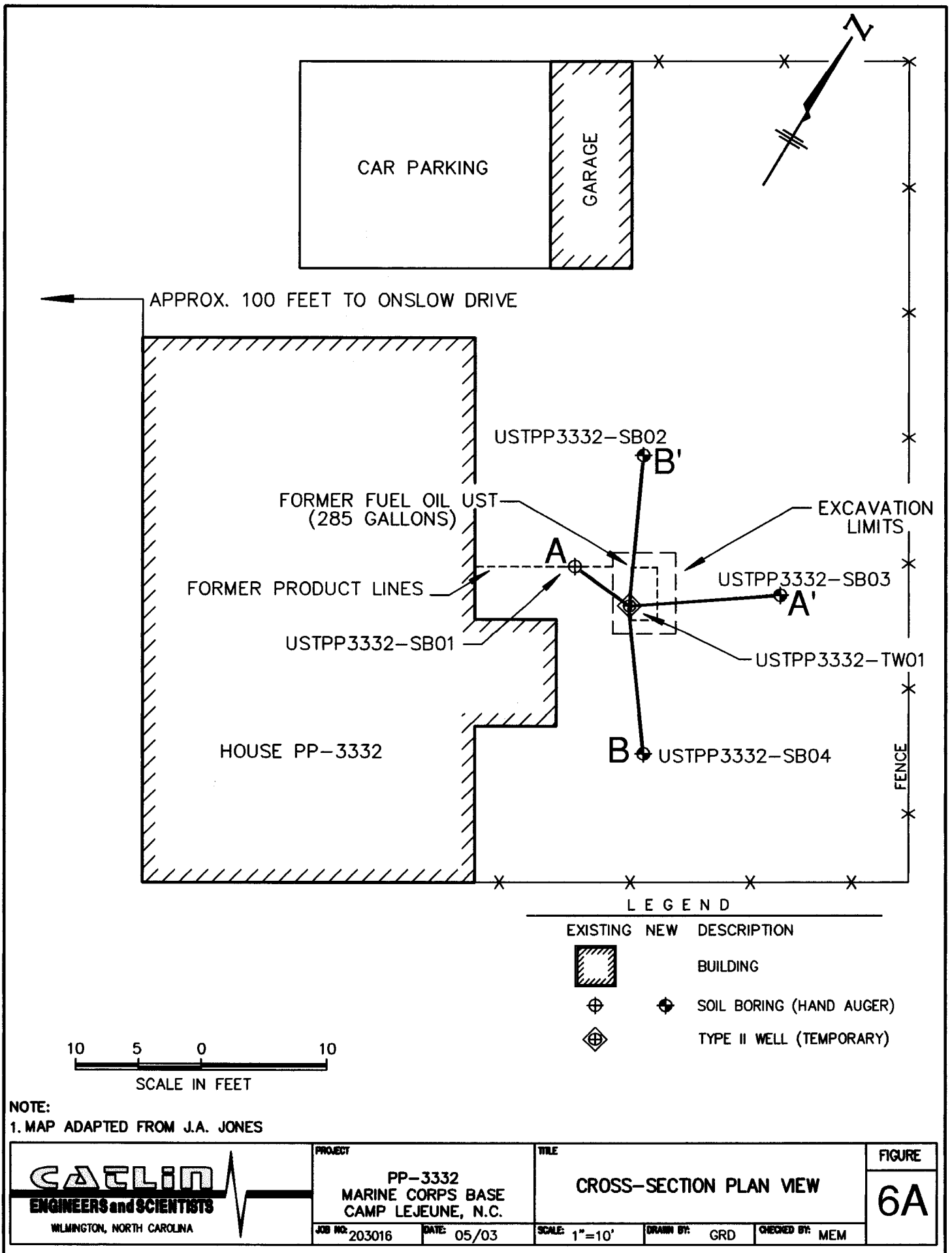

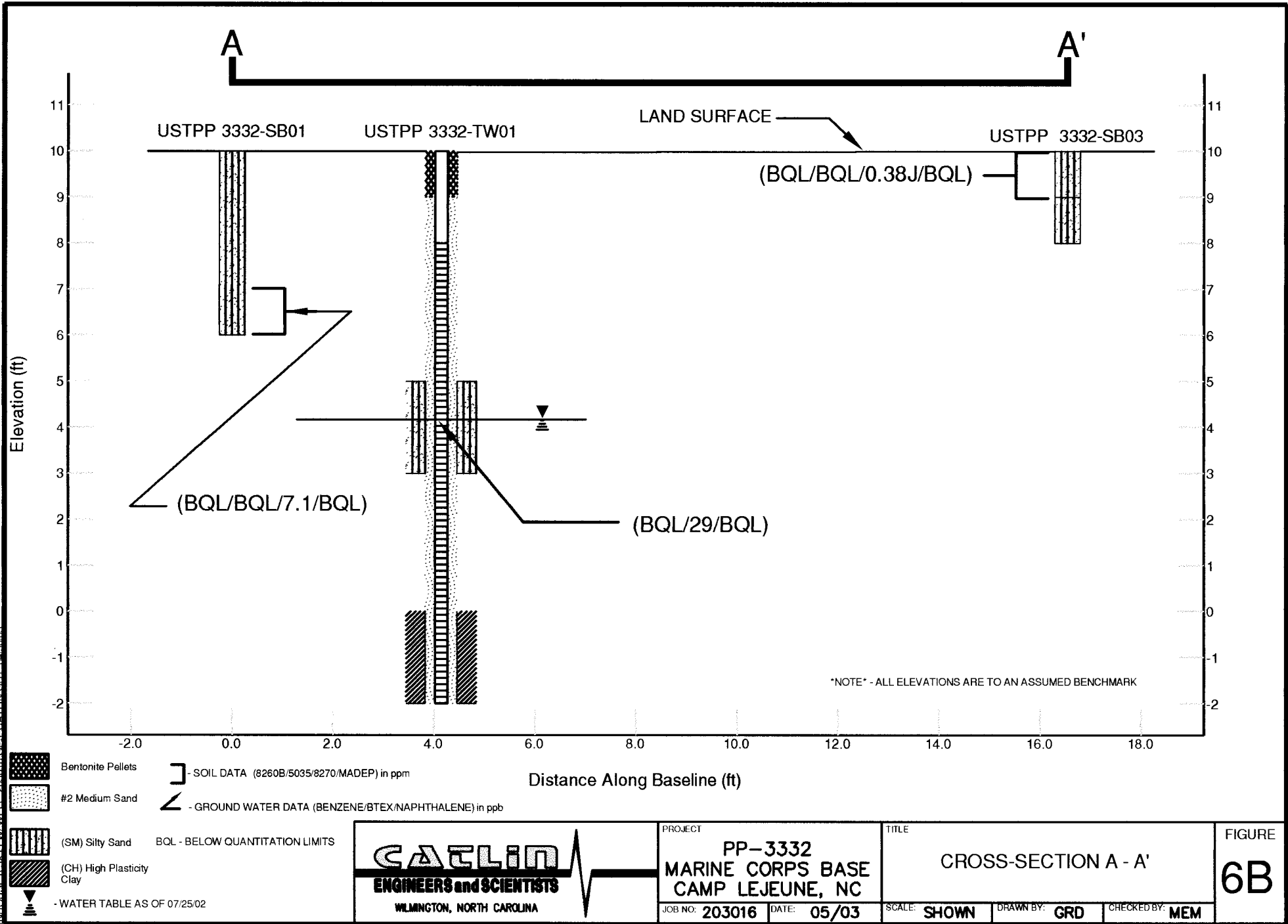





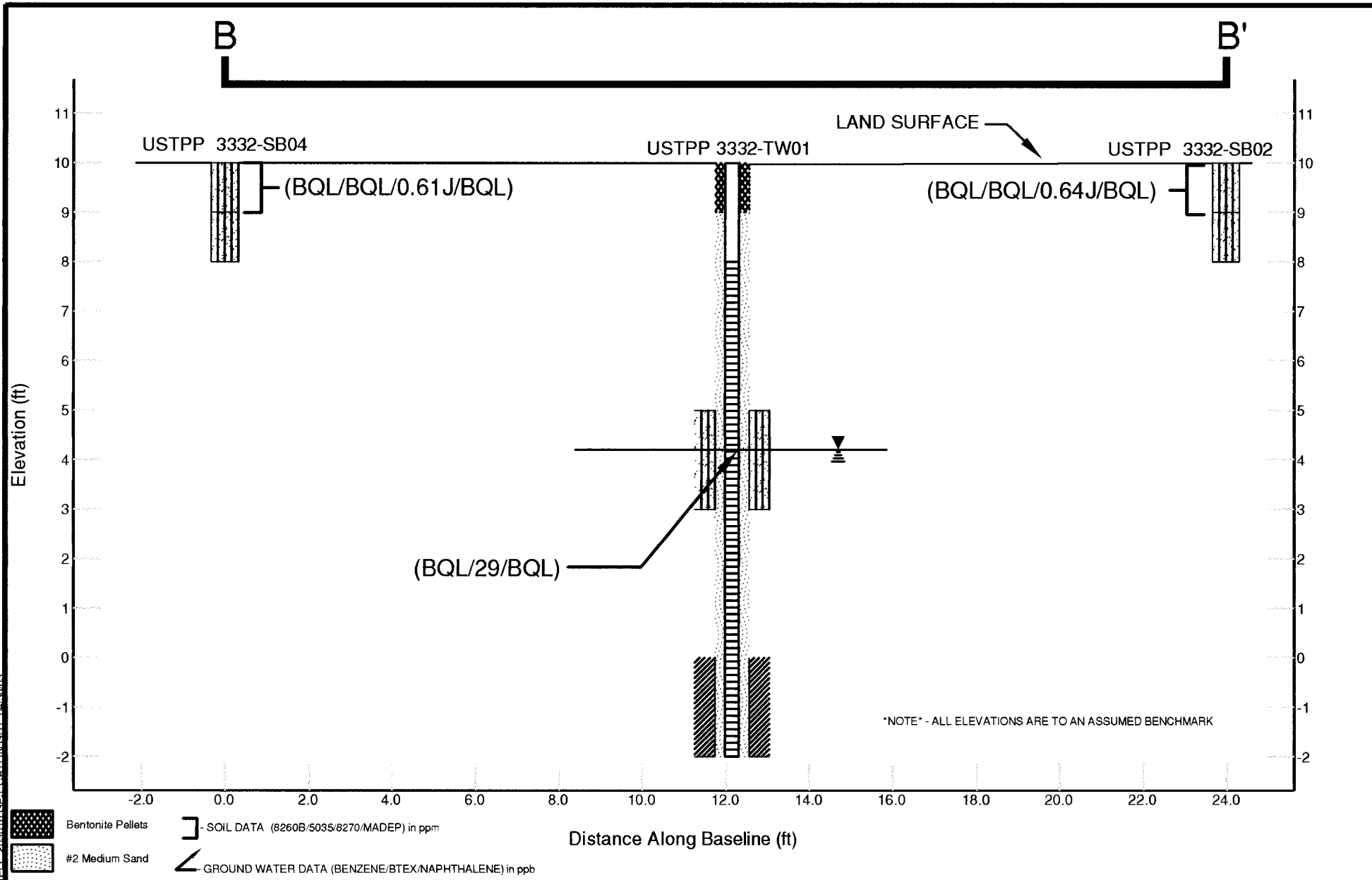



INHOUSE 8.5X11 W/ WELL 203016.GPJ CATLIN.GDT 04/20/03

INHQ/USE 4.5X11 W/WELL - 202016.GBL CATLIN.GDT 04/30/03



-  Bentonite Pellets
  -  #2 Medium Sand
  -  (SM) Silty Sand
  -  (CH) High Plasticity Clay
  -  - WATER TABLE AS OF 07/25/02
-  SOIL DATA (8260B/5035/8270/MADEP) in ppm  
 GROUND WATER DATA (BENZENE/BTEX/NAPHTHALENE) in ppb
- BQL - BELOW QUANTITATION LIMITS

 WILMINGTON, NORTH CAROLINA	PROJECT <b>PP-3332</b> <b>MARINE CORPS BASE</b> <b>CAMP LEJEUNE, NC</b>	TITLE <b>CROSS-SECTION B - B'</b>		FIGURE <b>6C</b>
	JOB NO: <b>203016</b> DATE: <b>05/03</b>	SCALE: <b>SHOWN</b>	DRAWN BY: <b>GRD</b>	CHECKED BY: <b>MEM</b>

## **APPENDICES**

**APPENDIX A**  
**BORING LOGS**

# WELL LOG

**CATLIN**  
ENGINEERS and SCIENTISTS  
Wilmington, North Carolina

SHEET 1 OF 1

PROJECT NO.: 203-016	STATE: NC	COUNTY: Onslow	LOCATION: MCB, Camp Lejuene
PROJECT NAME: PP-3332	LOGGED BY: Charles Ray	WELL ID: USTPP 3332-TW01	
	DRILLER: Bobbie Fowler		
NORTHING:	EASTING:	CREW: Tom Stetler	
SYSTEM: N/A	BORING LOCATION:		T.O.C. ELEV.: 10.00
DRILL MACHINE: CME 45B ATV	METHOD: HSA	0 HOUR DTW:	BORING DEPTH: 12.0
START DATE: 07/23/02	FINISH DATE: 07/23/02	24 HOUR DTW: 5.80	WELL DEPTH: 12.0

DEPTH	BLOW COUNT				OVA (ppm)	LAB.	USCS	LOG	SOIL AND ROCK DESCRIPTION	ELEVATION	WELL DETAIL
	6in	6in	6in	6in							
0.0									LAND SURFACE	10.0	0.0
5.0										5.0	
7.0	HP	HP	HP	HP		SM			Gray, SILTY, v.f. to f. SAND. Wet to sat. High HCO.	3.0	
10.0										10.0	
12.0	HP	HP	HP	HP		CH			Dark gray, v.f. to f., SILTY/SANDY CLAY with med. to high plasticity. Wet, High HCO.	-2.0	12.0
									Boring Terminated at Elevation -2.0 ft Elevation based on assumed land surface elevation of 10 feet.		12.0

CATLIN BORING LOG\_203016.GE1\_CATLIN.GDI\_05/02/03

 Bentonite Pellets     #2 Medium Sand

# BORING LOG

**CATLIN**  
ENGINEERS and SCIENTISTS

Wilmington, North Carolina

SHEET 1 OF 1

PROJECT NO.: 203-016	STATE: NC	COUNTY: Onslow	LOCATION: MCB, Camp Lejuene
PROJECT NAME: PP-3332	LOGGED BY: Charles Ray	BORING ID: USTPP 3332-SB01	
	DRILLER: Charles Ray		
NORTHING:	EASTING:	CREW: Tom Stetler	
SYSTEM: N/A	BORING LOCATION:		LAND ELEV.: 10.00
DRILL MACHINE: Hand Auger	METHOD: Hand Auger	0 HOUR DTW:	BORING DEPTH: 4.0
START DATE: 07/22/02	FINISH DATE: 07/22/02	24 HOUR DTW:	ROCK DEPTH: ---

DEPTH	BLOW COUNT 6" 6" 6" 6"	SAMP. TYPE	OVA RESULTS (ppm)	LAB.	USCS	LOG	SOIL AND ROCK		
							DEPTH	DESCRIPTION	ELEVATION
0.0			0 200 400 600 800 1000				0.0	LAND SURFACE	10
1.0		HA	▲0.2						
2.0		HA	▲0		SM			Dark Brown, SILTY, v.f. SAND with mixed topsoil and roots in top 1'. Dry to moist. No HCO.	
3.0		HA	▲0						
4.0		HA	▲0.4	sampled			4.0		6.0
								Boring Terminated at Elevation 6.0 ft Elevation based on assumed land surface elevation of 10 feet.	

CATLIN ENVIRO. LOG\_203016.GPJ\_CATLIN.GDT\_05/02/03

# BORING LOG

**CATLIN**  
ENGINEERS and SCIENTISTS

Wilmington, North Carolina

SHEET 1 OF 1

PROJECT NO.: 203-016	STATE: NC	COUNTY: Onslow	LOCATION: MCB, Camp Lejuene
PROJECT NAME: PP-3332	LOGGED BY: J. Carscallen	BORING ID: USTPP 3332-SB02	
	DRILLER: J. Carscallen		
NORTHING:	EASTING:	CREW:	
SYSTEM: N/A	BORING LOCATION:		LAND ELEV.: 10.00
DRILL MACHINE: Hand Auger	METHOD: Hand Auger	0 HOUR DTW:	BORING DEPTH: 3.5
START DATE: 03/24/03	FINISH DATE: 03/24/03	24 HOUR DTW:	ROCK DEPTH: ---

DEPTH	BLOW COUNT 6" 6" 6" 6"	SAMP. TYPE	OVA RESULTS (ppm) 0 200 400 600 800 1000	LAB.	U S C S	L O G	SOIL AND ROCK DESCRIPTION	
							DEPTH	ELEVATION
							0.0	LAND SURFACE 10.0
0.0					SM			SILTY SAND, ORANGE-BROWN; VERY FINE GRAINS; MOIST
1.0				SAMPLE	SM		1.0	SILTY SAND, ORANGE-BROWN; VERY FINE GRAINS; MOIST 9.0
2.0							2.0	SOIL WET AT 3.5 FEET BLS 8.0
							3.0	7.0
								Boring Terminated at Elevation 6.5 ft Elevation based on assumed land surface elevation of 10 feet.

CATLIN\ENVIRO.LOG\_203016.GPJ.CATLIN.GDT\_05/02/03

# BORING LOG

**CATLIN**

ENGINEERS and SCIENTISTS

Wilmington, North Carolina

SHEET 1 OF 1

PROJECT NO.: 203-016	STATE: NC	COUNTY: Onslow	LOCATION: MCB, Camp Lejuene
PROJECT NAME: PP-3332	LOGGED BY: J. Carscallen	BORING ID: USTPP	
	DRILLER: J. Carscallen	3332-SB03	
NORTHING:	EASTING:	CREW:	
SYSTEM: N/A	BORING LOCATION:		LAND ELEV.: 10.00
DRILL MACHINE: Hand Auger	METHOD: Hand Auger	0 HOUR DTW:	BORING DEPTH: 3.5
START DATE: 03/24/03	FINISH DATE: 03/24/03	24 HOUR DTW:	ROCK DEPTH: ---

DEPTH	BLOW COUNT 6" 6" 6" 6"	SAMP. TYPE	OVA RESULTS (ppm)	LAB.	U S C S	L O G	SOIL AND ROCK DESCRIPTION	
							DEPTH	ELEVATION
0.0			0 200 400 600 800 1000				0.0	LAND SURFACE 10.0
0.0					SM		0.0	SILTY SAND, ORANGE-BROWN; VERY FINE GRAINS; MOIST
1.0					SM		1.0	SILTY SAND, ORANGE-BROWN; VERY FINE GRAINS; MOIST
2.0					SM		2.0	SILTY SAND, ORANGE-BROWN; VERY FINE GRAINS; MOIST
							3.0	SOIL WET AT 3.5 FEET BLS
							7.0	Boring Terminated at Elevation 6.5 ft Elevation based on assumed land surface elevation of 10 feet.

CATLIN\ENVIRO.LOG\_203016.GPJ CATLIN.GDI\_05/02/03

# BORING LOG

**CATLIN**

ENGINEERS and SCIENTISTS

Wilmington, North Carolina

SHEET 1 OF 1

PROJECT NO.:	203-016	STATE:	NC	COUNTY:	Onslow	LOCATION:	MCB, Camp Lejeune	
PROJECT NAME:	PP-3332			LOGGED BY:	J. Carscallen		BORING ID:	
				DRILLER:	J. Carscallen		<b>USTPP</b>	
NORTHING:		EASTING:		CREW:			<b>3332-SB04</b>	
SYSTEM:	N/A		BORING LOCATION:			LAND ELEV.:		10.00
DRILL MACHINE:	Hand Auger		METHOD:	Hand Auger		0 HOUR DTW:	BORING DEPTH:	3.5
START DATE:	03/24/03		FINISH DATE:	03/24/03		24 HOUR DTW:	ROCK DEPTH:	---

DEPTH	BLOW COUNT				SAMP. TYPE	OVA RESULTS (ppm)	LAB.	U S C S	L O G	SOIL AND ROCK		
	6"	6"	6"	6"						DEPTH	DESCRIPTION	ELEVATION
0.0						0 200 400 600 800 1000				0.0	LAND SURFACE	10
1.0					▲0			SM		1.0	SILTY SAND, YELLOW/BROWN; VERY FINE GRAINS; MOIST	9.0
2.0					▲0		SAMPLE	SM		2.0	SILTY SAND, YELLOW/BROWN; VERY FINE GRAINS; MOIST	8.0
										3.0	SOIL WET AT 3.5 FEET BLS	7.0
											Boring Terminated at Elevation 6.5 ft Elevation based on assumed land surface elevation of 10 feet.	

**APPENDIX B**  
**NORTH CAROLINA WELL CONSTRUCTION RECORDS**  
***(NOT USED)***

**APPENDIX C**  
**FIELD MEASUREMENTS**  
***(NOT USED)***

**APPENDIX D**  
**STANDARD PROCEDURES**

# CATLIN STANDARD METHODS OF INVESTIGATION

(REVISED APRIL 2002)

## 1.0 DATA COLLECTION

### 1.1 BACKGROUND DATA

Background data and history information relevant to the site investigation is generated through numerous sources. These sources may include, but are not limited to, the following:

- Conversations with the client and regulatory officials involved with the incident.
- Review of pertinent regulatory correspondence.
- Review of previous and existing reports and other technical data.
- Review of available historical records.

### 1.2 SURVEYS AND POTENTIAL RECEPTOR DATA

Physical survey and potential receptor data are collected in accordance with the intended level of investigation. In general, the purpose is to collect sufficient information for site assessment and corrective action planning.

Individual receptors are identified and evaluated in the context of their potential for contaminant impact. Potential receptors of contamination can include surface water bodies, groundwater supply wells, wellhead protection areas, and subsurface building structures.

#### 1.2.1 Horizontal Survey

Horizontal survey data are generated using either accepted general field surveying techniques, or existing survey maps; or by using a combination of existing data and field generated information. The survey area generally extends to a point at least 50 feet beyond suspected plume boundaries. A receptor scale survey of a larger area surrounding a site will be made if appropriate and necessary.

#### 1.2.2 Vertical Survey

A vertical survey is conducted at the site typically within an accuracy of 0.01 foot. The datum plane is generally assumed unless otherwise noted. Assumed temporary benchmarks (TBM) are selected near ground level. The vertical survey includes such points as top of all well casings, selected ground shots, important utility inverts, utility fluid levels, important surface water levels, and other items determined to be significant.

### **1.3 DRILLING AND MONITORING WELL/PIEZOMETER INSTALLATION**

Necessary permits are applied for and obtained in accordance with federal, state, and local requirements prior to drilling or well construction activities. Additionally, the well locations are scanned for underground utilities prior to conducting intrusive subsurface activities. Wells are installed under applicable licensing requirements, and are designed and constructed in accordance with accepted standards and practices. Any wells purposely installed at off-site locations are permitted through appropriate right-of-entry agreements with all necessary property owners and/or their agents.

#### **1.3.1 Drilling Methods and Subsurface Data Collection**

Drilling is accomplished utilizing one or more of the following methods:

##### ***Auger Drilling***

Auger drilling is the preferred, most often used method of subsurface investigation and is accomplished using a vehicle or trailer mounted drill rig. Continuous flight auger types used vary upon the site and situation; ranging from the 4-inch outside diameter solid stem to the 12-inch outside diameter hollow stem. Auger type is selected based upon appropriateness and/or site-specific requirements.

##### ***Hand Augering***

Hand augering is utilized when economically and scientifically feasible, or when no other method is suitable. Hand augers typically produce three-inch diameter holes and are generally limited to depths of less than 15 feet.

##### ***Direct Push***

Direct push methods of subsurface investigation are used generally for soil screening purposes or collection of groundwater samples where permanent wells are not viable.

##### ***Other Methods***

Other drilling methods, such as mud and air rotary, rock coring, cable tool, and large bucket augering are used when site conditions or project requirements dictate.

Regardless of the drilling method used, the drill rig(s) and all drilling tools are thoroughly cleaned between boreholes to prevent cross introduction of contaminants. Split spoon samples are collected and field-described at intervals of five feet or less, and cuttings are continuously monitored for organic vapors. Drill cuttings are containerized for off-site disposal or are spread on the ground surface in proximity to the well or boring in accordance with North Carolina Department of Environment and Natural Resources (NCDENR) requirements. A geologist or engineer, trained in using visual/manual techniques, is always present during drilling and is responsible for subsurface contaminant and geologic data collection. Soils are classified in general agreement with the Unified Soils Classification System (USCS).

### **1.3.2 Hydropunch Installation**

Hydropunch penetrometers (Hydropunches) are used to delineate the spatial extent of dissolved and free phase plumes. Soil borings are advanced to the appropriate depth and then the Hydropunch is advanced through the soil boring into undisturbed material. Groundwater samples are collected by pulling back on the body of the Hydropunch and allowing the groundwater to enter the screened portion of the sample chamber. Samples are retrieved using a decontaminated Teflon bailer or peristaltic pump.

### **1.3.3 Well Installation**

Wells are typically constructed of threaded PVC casing and screen. No glues or cements are used in joining PVC components. Well diameter, slot sizes, and protective covers vary depending upon site-specific conditions or situation-specific requirements.

### **1.3.4 Well Development**

Wells are developed by over-pumping or surging using appropriate pumps, blocks, or bailers. Through development, unwanted fine materials are removed from the natural formation surrounding the well. Well development will be performed no sooner than 24-hours after grouting is completed for the Type III wells. Water generated during development is containerized and properly disposed or is discharged onto the ground in proximity of the well in accordance with NCDENR requirements.

## **1.4 HYDROGEOLOGIC DATA COLLECTION**

Data used to help characterize hydrogeologic conditions at a site are obtained through various procedures including, but not necessarily limited to, those described below:

#### **1.4.1 Regional Geology**

Information pertaining to the regional geologic framework is compiled from existing publications, maps, and scientific papers.

#### **1.4.2 Site Geology**

Shallow site geology is generally determined from field descriptions and borehole samples. Interpretations with regard to hydrogeologically important contacts, zones, fractures, faults, cleavage, and facies changes are made when possible.

#### **1.4.3 Groundwater Occurrence and Characteristics**

Groundwater data is obtained utilizing a number of methods and procedures, not limited to the general list below:

##### ***Well Water Levels***

After well development, wells are allowed to stabilize for a minimum of 24 hours prior to measuring. Water level and free product thickness (where applicable) measurements are performed using an electronic interface probe or steel tape with water/product finding pastes.

The specific gravity of any accumulated product is determined and used to calculate true hydraulic grade from measured water levels. This information is combined with vertical survey data to determine relative potentiometric surface elevations for all wells.

##### ***Aquifer Testing***

Various aquifer tests may be used to make determinations of hydraulic conductivity. Slug or pumping tests are often used to characterize site hydrogeologic conditions and to develop remedial action alternatives utilizing appropriate pumping technologies.

##### ***Other Methods***

Other methods may be deemed appropriate for determining various groundwater characteristics. These other methods may include nested well configurations and/or clustered piezometer installations; sieve or pipette analysis; fracture trace analysis; computer modeling; and geophysical logging.

## **1.5 PETROLEUM HYDROCARBON DATA COLLECTION**

### **1.5.1 Collection Methods**

Petroleum hydrocarbon data is obtained through various methods including, but not limited to, the following:

#### ***Field Analysis***

- Direct thickness measurement of phase separated components using tapes and/or probes.
- Manual vapor analysis using a photoionization detector (PID) or flame ionization detector (FIS).
- Detectable odor and visual observation.

#### ***Laboratory Analysis***

- Laboratory analysis of phase-separated products.
- Laboratory vapor, soil, and groundwater analysis using appropriate EPA Methods.

### **1.5.2 Field Sampling**

Field sampling procedures are performed in accordance with recommended protocol, accepted industry standards, and under appropriate chain-of-custody procedures. Generally, sampling procedures are as follows:

#### ***Product Samples***

Product samples are obtained using clean equipment and containers. Each is shipped to the analytical laboratory in protective containers.

#### ***Vapor Samples***

PID/FID readings are measured from soil sample headspace using containerized samples that have been brought to ambient temperature.

Carbon tubes are utilized in conjunction with a laboratory-calibrated vacuum pump to obtain vapor samples. The carbon tubes are sealed and refrigerated for shipment to the analytical laboratory (This method is known as the Carbon Adsorption Method).

### *Soil Samples*

Soil samples are immediately packed into clean containers, and refrigerated for shipment to the analytical laboratory.

### *Groundwater Samples*

Groundwater samples are collected in accordance with the following procedures:

- Creeks/Lakes/Etc.

Grab samples are obtained.

- Domestic Wells

Wells are pumped for a time sufficient to completely purge the well and any pressure or holding tanks prior to sampling.

- Monitoring Wells

Water level measurements are made and well volumes calculated for each well.

Three well volumes are removed from each well using a thoroughly cleaned Teflon bailer or appropriate purging pump. If it is not possible to remove three volumes, due to very low yields, a minimum of one volume is removed prior to obtaining a sample.

Where analysis for metals is required, wells are typically sampled utilizing low flow techniques, which reduce turbidity and the potential for matrix interference.

Samples are collected and containerized in a manner that minimizes agitation and contact with the air.

Sampling records are field prepared.

Samples are labeled and proper chain of custody documents are maintained.

Samples are promptly protectively packed, refrigerated, and shipped to the analytical laboratory for analysis.

## 2.0 DATA EVALUATION

Data obtained as a result of the site investigation is compiled and evaluated and a report is prepared for client review and distribution to the appropriate agencies. Generally, specific data are evaluated as follows:

- Background data are evaluated in context with the suspected or confirmed problem.
- Survey data are utilized to develop site maps and to evaluate contaminant receptors.
- Well construction records are compiled and presented as part of the report. As-built information is used in combination with other data to evaluate subsurface conditions and monitoring well screen settings as they relate to the investigation.
- Subsurface drilling logs are used to develop geologic cross-sections, fence diagrams, isopachs, structure contours, or other constructions. Regional geologic data are used to obtain an overall framework.
- Hydrogeologic data are used to develop contour maps, flow nets and other constructions. The data is also used to calculate various hydrogeologic parameters that describe aquifer characteristics.
- Hydrocarbon data are utilized to develop various plume geometry and isoconcentration maps.
- All data are compiled and utilized for making specific recommendations with regard to remedial action alternatives.

**APPENDIX E**

**LABORATORY REPORTS  
AND  
CHAIN-OF-CUSTODY DOCUMENTATION**

**FILE COPY**

203-016

**PARADIGM ANALYTICAL LABORATORIES, INC.**  
2627 Northchase Parkway S.E.  
Wilmington, North Carolina 28405  
(910) 350-1903  
Fax (910) 350-1557

Mr. Mike E. Mason  
Richard Catlin & Associates  
P.O. Box 10279  
Wilmington, NC 28404-0279

April 8, 2003

Report Number: G128-1082

Client Project ID: PP-3332

Dear Mr. Mason,

Enclosed are the results of the analytical services performed under the referenced project. Copies of this report and supporting data will be retained in our files for a period of five years in the event they are required for future reference. Any samples submitted to our laboratory will be retained for a maximum of thirty (30) days from the date of this report unless other arrangements are requested.

If there are any questions about the report or the services performed during this project, please call for assistance. We will be happy to answer any questions or concerns which you may have.

Thank you for using Paradigm Analytical Labs for your analytical services. We look forward to working with you again on any additional analytical needs which you may have.

Sincerely,

Paradigm Analytical Laboratories, Inc.



---

Laboratory Director  
J. Patrick Weaver

**PARADIGM ANALYTICAL LABORATORIES, INC.**

**Results for Volatiles**

by GCMS 8260B/5035

Client Sample ID: USTPP3332-SB02 (1-2)

Date Analyzed: 3/31/03

Client Project ID: PP-3332

Analyzed By: EKR

Lab Sample ID: 66354

Date Collected: 3/25/03

Lab Project ID: G128-1082

Date Received: 3/25/03

Matrix: Soil

%Solids: 82.5

Dilution: 1

<b>Compound</b>	<b>Quantitation Limit (mg/KG)</b>	<b>Result (mg/KG)</b>
Acetone	0.061	BQL
Acrolein	0.12	BQL
Acrylonitrile	0.12	BQL
Benzene	0.0061	BQL
Bromobenzene	0.0061	BQL
Bromochloromethane	0.0061	BQL
Bromodichloromethane	0.0061	BQL
Bromoform	0.0061	BQL
Bromomethane	0.0061	BQL
2-Butanone	0.03	BQL
n-Butylbenzene	0.0061	BQL
sec-Butylbenzene	0.0061	BQL
tert-Butylbenzene	0.0061	BQL
Carbon disulfide	0.0061	BQL
Carbon tetrachloride	0.0061	BQL
Chlorobenzene	0.0061	BQL
Chloroethane	0.0061	BQL
2-Chloroethyl vinyl ether	0.0061	BQL
Chloroform	0.0061	BQL
Chloromethane	0.0061	BQL
2-Chlorotoluene	0.0061	BQL
4-Chlorotoluene	0.0061	BQL
Dibromochloromethane	0.0061	BQL
1,2-Dibromo-3-chloropropane	0.0061	BQL
Dibromomethane	0.0061	BQL
1,2-Dibromoethane (EDB)	0.0061	BQL
1,2-Dichlorobenzene	0.0061	BQL
1,3-Dichlorobenzene	0.0061	BQL
1,4-Dichlorobenzene	0.0061	BQL
trans-1,4-Dichloro-2-butene	0.0061	BQL
1,1-Dichloroethane	0.0061	BQL
1,1-Dichloroethene	0.0061	BQL
1,2-Dichloroethane	0.0061	BQL
cis-1,2-Dichloroethene	0.0061	BQL
trans-1,2-dichloroethene	0.0061	BQL
1,2-Dichloropropane	0.0061	BQL
1,3-Dichloropropane	0.0061	BQL
2,2-Dichloropropane	0.0061	BQL
1,1-Dichloropropene	0.0061	BQL
cis-1,3-Dichloropropene	0.0061	BQL
trans-1,3-Dichloropropene	0.0061	BQL
Dichlorodifluoromethane	0.0061	BQL
Diisopropyl ether (DIPE)	0.0061	BQL
Ethylbenzene	0.0061	BQL
Hexachlorobutadiene	0.0061	BQL

Reviewed by: mle

**PARADIGM ANALYTICAL LABORATORIES, INC.**

**Results for Volatiles**

by GCMS 8260B/5035

Client Sample ID: USTPP3332-SB02 (1-2)

Date Analyzed: 3/31/03

Client Project ID: PP-3332

Analyzed By: EKR

Lab Sample ID: 66354

Date Collected: 3/25/03

Lab Project ID: G128-1082

Date Received: 3/25/03

Matrix: Soil

%Solids: 82.5

Dilution: 1

Compound	Quantitation Limit (mg/KG)	Result (mg/KG)
2-Hexanone	0.0061	BQL
Iodomethane	0.0061	BQL
Isopropylbenzene	0.0061	BQL
4-Isopropyltoluene	0.0061	BQL
Methylene chloride	0.024	BQL
4-Methyl-2-pentanone	0.0061	BQL
Methyl-tert-butyl ether (MTBE)	0.0061	BQL
Naphthalene	0.0061	BQL
n-Propyl benzene	0.0061	BQL
Styrene	0.0061	BQL
1,1,1,2-Tetrachloroethane	0.0061	BQL
1,1,2,2-Tetrachloroethane	0.0061	BQL
Tetrachloroethene	0.0061	BQL
Toluene	0.0061	BQL
1,2,3-Trichlorobenzene	0.0061	BQL
1,2,4-Trichlorobenzene	0.0061	BQL
Trichloroethene	0.0061	BQL
1,1,1-Trichloroethane	0.0061	BQL
1,1,2-Trichloroethane	0.0061	BQL
Trichlorofluoromethane	0.0061	BQL
1,2,3-Trichloropropane	0.0061	BQL
1,2,4-Trimethylbenzene	0.0061	BQL
1,3,5-Trimethylbenzene	0.0061	BQL
Vinyl chloride	0.0061	BQL
m-,p-Xylene	0.012	BQL
o-Xylene	0.0061	BQL

Surrogate Spike Recoveries	Spike Added (mg/KG)	Surrogate Result (mg/KG)	%Rec
Compound			
Bromofluorobenzene	0.0500	0.0484	97
1,2-Dichloroethane-d4	0.0500	0.0543	109
Toluene-d8	0.0500	0.0499	100

**Comments:**

All results are corrected for dilution.

Reviewed by: jmrc

**PARADIGM ANALYTICAL LABORATORIES, INC.**

**Results for Volatiles**

by GCMS 8260B/5035

Client Sample ID: USTPP3332-SB03 (1-2)	Date Analyzed: 3/31/03
Client Project ID: PP-3332	Analyzed By: EKR
Lab Sample ID: 66355	Date Collected: 3/25/03
Lab Project ID: G128-1082	Date Received: 3/25/03
Matrix: Soil	Dilution: 1
%Solids: 89.5	

Compound	Quantitation Limit (mg/KG)	Result (mg/KG)
Acetone	0.056	BQL
Acrolein	0.11	BQL
Acrylonitrile	0.11	BQL
Benzene	0.0056	BQL
Bromobenzene	0.0056	BQL
Bromochloromethane	0.0056	BQL
Bromodichloromethane	0.0056	BQL
Bromoform	0.0056	BQL
Bromomethane	0.0056	BQL
2-Butanone	0.028	BQL
n-Butylbenzene	0.0056	BQL
sec-Butylbenzene	0.0056	BQL
tert-Butylbenzene	0.0056	BQL
Carbon disulfide	0.0056	BQL
Carbon tetrachloride	0.0056	BQL
Chlorobenzene	0.0056	BQL
Chloroethane	0.0056	BQL
2-Chloroethyl vinyl ether	0.0056	BQL
Chloroform	0.0056	BQL
Chloromethane	0.0056	BQL
2-Chlorotoluene	0.0056	BQL
4-Chlorotoluene	0.0056	BQL
Dibromochloromethane	0.0056	BQL
1,2-Dibromo-3-chloropropane	0.0056	BQL
Dibromomethane	0.0056	BQL
1,2-Dibromoethane (EDB)	0.0056	BQL
1,2-Dichlorobenzene	0.0056	BQL
1,3-Dichlorobenzene	0.0056	BQL
1,4-Dichlorobenzene	0.0056	BQL
trans-1,4-Dichloro-2-butene	0.0056	BQL
1,1-Dichloroethane	0.0056	BQL
1,1-Dichloroethene	0.0056	BQL
1,2-Dichloroethane	0.0056	BQL
cis-1,2-Dichloroethene	0.0056	BQL
trans-1,2-dichloroethene	0.0056	BQL
1,2-Dichloropropane	0.0056	BQL
1,3-Dichloropropane	0.0056	BQL
2,2-Dichloropropane	0.0056	BQL
1,1-Dichloropropene	0.0056	BQL
cis-1,3-Dichloropropene	0.0056	BQL
trans-1,3-Dichloropropene	0.0056	BQL
Dichlorodifluoromethane	0.0056	BQL
Diisopropyl ether (DIPE)	0.0056	BQL
Ethylbenzene	0.0056	BQL
Hexachlorobutadiene	0.0056	BQL

Reviewed by: MLC

**PARADIGM ANALYTICAL LABORATORIES, INC.**

**Results for Volatiles**

by GCMS 8260B/5035

Client Sample ID: USTPP3332-SB03 (1-2)

Date Analyzed: 3/31/03

Client Project ID: PP-3332

Analyzed By: EKR

Lab Sample ID: 66355

Date Collected: 3/25/03

Lab Project ID: G128-1082

Date Received: 3/25/03

Matrix: Soil

%Solids: 89.5

Dilution: 1

Compound	Quantitation Limit (mg/KG)	Result (mg/KG)
2-Hexanone	0.0056	BQL
Iodomethane	0.0056	BQL
Isopropylbenzene	0.0056	BQL
4-Isopropyltoluene	0.0056	BQL
Methylene chloride	0.022	BQL
4-Methyl-2-pentanone	0.0056	BQL
Methyl-tert-butyl ether (MTBE)	0.0056	BQL
Naphthalene	0.0056	BQL
n-Propyl benzene	0.0056	BQL
Styrene	0.0056	BQL
1,1,1,2-Tetrachloroethane	0.0056	BQL
1,1,2,2-Tetrachloroethane	0.0056	BQL
Tetrachloroethene	0.0056	BQL
Toluene	0.0056	BQL
1,2,3-Trichlorobenzene	0.0056	BQL
1,2,4-Trichlorobenzene	0.0056	BQL
Trichloroethene	0.0056	BQL
1,1,1-Trichloroethane	0.0056	BQL
1,1,2-Trichloroethane	0.0056	BQL
Trichlorofluoromethane	0.0056	BQL
1,2,3-Trichloropropane	0.0056	BQL
1,2,4-Trimethylbenzene	0.0056	BQL
1,3,5-Trimethylbenzene	0.0056	BQL
Vinyl chloride	0.0056	BQL
m-,p-Xylene	0.011	BQL
o-Xylene	0.0056	BQL

**Surrogate Spike Recoveries**

Compound	Spike Added (mg/KG)	Surrogate Result (mg/KG)	%Rec
Bromofluorobenzene	0.0500	0.0465	93
1,2-Dichloroethane-d4	0.0500	0.0547	109
Toluene-d8	0.0500	0.0496	99

**Comments:**

All results are corrected for dilution.

Reviewed by: MLC

**PARADIGM ANALYTICAL LABORATORIES, INC.**

**Results for Volatiles**  
by GCMS 8260B/5035

Client Sample ID: USTPP3332-SB04 (1-2)	Date Analyzed: 3/31/03
Client Project ID: PP-3332	Analyzed By: EKR
Lab Sample ID: 66356	Date Collected: 3/25/03
Lab Project ID: G128-1082	Date Received: 3/25/03
Matrix: Soil	Dilution: 1
%Solids: 91.8	

Compound	Quantitation Limit (mg/KG)	Result (mg/KG)
Acetone	0.054	BQL
Acrolein	0.11	BQL
Acrylonitrile	0.11	BQL
Benzene	0.0054	BQL
Bromobenzene	0.0054	BQL
Bromochloromethane	0.0054	BQL
Bromodichloromethane	0.0054	BQL
Bromoform	0.0054	BQL
Bromomethane	0.0054	BQL
2-Butanone	0.027	BQL
n-Butylbenzene	0.0054	BQL
sec-Butylbenzene	0.0054	BQL
tert-Butylbenzene	0.0054	BQL
Carbon disulfide	0.0054	BQL
Carbon tetrachloride	0.0054	BQL
Chlorobenzene	0.0054	BQL
Chloroethane	0.0054	BQL
2-Chloroethyl vinyl ether	0.0054	BQL
Chloroform	0.0054	BQL
Chloromethane	0.0054	BQL
2-Chlorotoluene	0.0054	BQL
4-Chlorotoluene	0.0054	BQL
Dibromochloromethane	0.0054	BQL
1,2-Dibromo-3-chloropropane	0.0054	BQL
Dibromomethane	0.0054	BQL
1,2-Dibromoethane (EDB)	0.0054	BQL
1,2-Dichlorobenzene	0.0054	BQL
1,3-Dichlorobenzene	0.0054	BQL
1,4-Dichlorobenzene	0.0054	BQL
trans-1,4-Dichloro-2-butene	0.0054	BQL
1,1-Dichloroethane	0.0054	BQL
1,1-Dichloroethene	0.0054	BQL
1,2-Dichloroethane	0.0054	BQL
cis-1,2-Dichloroethene	0.0054	BQL
trans-1,2-dichloroethene	0.0054	BQL
1,2-Dichloropropane	0.0054	BQL
1,3-Dichloropropane	0.0054	BQL
2,2-Dichloropropane	0.0054	BQL
1,1-Dichloropropene	0.0054	BQL
cis-1,3-Dichloropropene	0.0054	BQL
trans-1,3-Dichloropropene	0.0054	BQL
Dichlorodifluoromethane	0.0054	BQL
Diisopropyl ether (DIPE)	0.0054	BQL
Ethylbenzene	0.0054	BQL
Hexachlorobutadiene	0.0054	BQL

Reviewed by: mit

**PARADIGM ANALYTICAL LABORATORIES, INC.**

**Results for Volatiles**

by GCMS 8260B/5035

Client Sample ID: USTPP3332-SB04 (1-2)

Date Analyzed: 3/31/03

Client Project ID: PP-3332

Analyzed By: EKR

Lab Sample ID: 66356

Date Collected: 3/25/03

Lab Project ID: G128-1082

Date Received: 3/25/03

Matrix: Soil

%Solids: 91.8

Dilution: 1

Compound	Quantitation Limit (mg/KG)	Result (mg/KG)
2-Hexanone	0.0054	BQL
Iodomethane	0.0054	BQL
Isopropylbenzene	0.0054	BQL
4-Isopropyltoluene	0.0054	BQL
Methylene chloride	0.022	BQL
4-Methyl-2-pentanone	0.0054	BQL
Methyl-tert-butyl ether (MTBE)	0.0054	BQL
Naphthalene	0.0054	BQL
n-Propyl benzene	0.0054	BQL
Styrene	0.0054	BQL
1,1,1,2-Tetrachloroethane	0.0054	BQL
1,1,2,2-Tetrachloroethane	0.0054	BQL
Tetrachloroethene	0.0054	BQL
Toluene	0.0054	BQL
1,2,3-Trichlorobenzene	0.0054	BQL
1,2,4-Trichlorobenzene	0.0054	BQL
Trichloroethene	0.0054	BQL
1,1,1-Trichloroethane	0.0054	BQL
1,1,2-Trichloroethane	0.0054	BQL
Trichlorofluoromethane	0.0054	BQL
1,2,3-Trichloropropane	0.0054	BQL
1,2,4-Trimethylbenzene	0.0054	BQL
1,3,5-Trimethylbenzene	0.0054	BQL
Vinyl chloride	0.0054	BQL
m-,p-Xylene	0.011	BQL
o-Xylene	0.0054	BQL

Surrogate Spike Recoveries	Spike Added (mg/KG)	Surrogate Result (mg/KG)	%Rec
Compound			
Bromofluorobenzene	0.0500	0.0493	99
1,2-Dichloroethane-d4	0.0500	0.0544	109
Toluene-d8	0.0500	0.0508	102

**Comments:**

All results are corrected for dilution.

Reviewed by: myk

**PARADIGM ANALYTICAL LABORATORIES, INC.**

**Results for Volatiles**

by GCMS 8260B/5035

Client Sample ID: USTPP3332-SB04D (1-2)	Date Analyzed: 3/31/03
Client Project ID: PP-3332	Analyzed By: EKR
Lab Sample ID: 66357	Date Collected: 3/25/03
Lab Project ID: G128-1082	Date Received: 3/25/03
Matrix: Soil	Dilution: 1
%Solids: 91.8	

Compound	Quantitation Limit (mg/KG)	Result (mg/KG)
Acetone	0.054	BQL
Acrolein	0.11	BQL
Acrylonitrile	0.11	BQL
Benzene	0.0054	BQL
Bromobenzene	0.0054	BQL
Bromochloromethane	0.0054	BQL
Bromodichloromethane	0.0054	BQL
Bromoform	0.0054	BQL
Bromomethane	0.0054	BQL
2-Butanone	0.027	BQL
n-Butylbenzene	0.0054	BQL
sec-Butylbenzene	0.0054	BQL
tert-Butylbenzene	0.0054	BQL
Carbon disulfide	0.0054	BQL
Carbon tetrachloride	0.0054	BQL
Chlorobenzene	0.0054	BQL
Chloroethane	0.0054	BQL
2-Chloroethyl vinyl ether	0.0054	BQL
Chloroform	0.0054	BQL
Chloromethane	0.0054	BQL
2-Chlorotoluene	0.0054	BQL
4-Chlorotoluene	0.0054	BQL
Dibromochloromethane	0.0054	BQL
1,2-Dibromo-3-chloropropane	0.0054	BQL
Dibromomethane	0.0054	BQL
1,2-Dibromoethane (EDB)	0.0054	BQL
1,2-Dichlorobenzene	0.0054	BQL
1,3-Dichlorobenzene	0.0054	BQL
1,4-Dichlorobenzene	0.0054	BQL
trans-1,4-Dichloro-2-butene	0.0054	BQL
1,1-Dichloroethane	0.0054	BQL
1,1-Dichloroethene	0.0054	BQL
1,2-Dichloroethane	0.0054	BQL
cis-1,2-Dichloroethene	0.0054	BQL
trans-1,2-dichloroethene	0.0054	BQL
1,2-Dichloropropane	0.0054	BQL
1,3-Dichloropropane	0.0054	BQL
2,2-Dichloropropane	0.0054	BQL
1,1-Dichloropropene	0.0054	BQL
cis-1,3-Dichloropropene	0.0054	BQL
trans-1,3-Dichloropropene	0.0054	BQL
Dichlorodifluoromethane	0.0054	BQL
Diisopropyl ether (DIPE)	0.0054	BQL
Ethylbenzene	0.0054	BQL
Hexachlorobutadiene	0.0054	BQL

Reviewed by: AKC

**PARADIGM ANALYTICAL LABORATORIES, INC.**

**Results for Volatiles**

by GCMS 8260B/5035

Client Sample ID: USTPP3332-SB04D (1-2)	Date Analyzed: 3/31/03
Client Project ID: PP-3332	Analyzed By: EKR
Lab Sample ID: 66357	Date Collected: 3/25/03
Lab Project ID: G128-1082	Date Received: 3/25/03
Matrix: Soil	Dilution: 1
%Solids: 91.8	

Compound	Quantitation Limit (mg/KG)	Result (mg/KG)
2-Hexanone	0.0054	BQL
Iodomethane	0.0054	BQL
Isopropylbenzene	0.0054	BQL
4-Isopropyltoluene	0.0054	BQL
Methylene chloride	0.022	BQL
4-Methyl-2-pentanone	0.0054	BQL
Methyl-tert-butyl ether (MTBE)	0.0054	BQL
Naphthalene	0.0054	BQL
n-Propyl benzene	0.0054	BQL
Styrene	0.0054	BQL
1,1,1,2-Tetrachloroethane	0.0054	BQL
1,1,2,2-Tetrachloroethane	0.0054	BQL
Tetrachloroethene	0.0054	BQL
Toluene	0.0054	BQL
1,2,3-Trichlorobenzene	0.0054	BQL
1,2,4-Trichlorobenzene	0.0054	BQL
Trichloroethene	0.0054	BQL
1,1,1-Trichloroethane	0.0054	BQL
1,1,2-Trichloroethane	0.0054	BQL
Trichlorofluoromethane	0.0054	BQL
1,2,3-Trichloropropane	0.0054	BQL
1,2,4-Trimethylbenzene	0.0054	BQL
1,3,5-Trimethylbenzene	0.0054	BQL
Vinyl chloride	0.0054	BQL
m-,p-Xylene	0.011	BQL
o-Xylene	0.0054	BQL

Surrogate Spike Recoveries	Spike Added	Surrogate Result	%Rec
Compound	(mg/KG)	(mg/KG)	
Bromofluorobenzene	0.0500	0.0490	98
1,2-Dichloroethane-d4	0.0500	0.0550	110
Toluene-d8	0.0500	0.0511	102

**Comments:**

All results are corrected for dilution.

Reviewed by: MLC

VPH (Aliphatics/Aromatics) Laboratory Reporting Form

Client Name: Richard Catlin & Associates

Project Name: PP-3332

Sample Information and Analytical Results	
Sample Identification	USTPP3332-SB02 (1-2)
Sample Matrix	Soil
Collection Option (for Soil)*	3
Date Collected	03/25/03
Date Received	03/25/03
Date Extracted	03/25/03
Date Analyzed	03/29/03
Dry Weight	82
Dilution Factor	1
C <sub>5</sub> -C <sub>8</sub> Aliphatics**	< 10 (mg/Kg)
C <sub>9</sub> -C <sub>12</sub> Aliphatics**	< 10 (mg/Kg)
C <sub>9</sub> -C <sub>10</sub> Aromatics**	< 10 (mg/Kg)
Surrogate % Recovery - PID	94
Surrogate % Recovery - FID	120

\* = Option 1 = Established fill line on vial, Option 2 = Sampling Device/Brand, or Option 3 = Field weight of soil.

\*\* = Excludes any surrogates or internal standards.

Lab Info: G128-1082-66354

Reviewed By: mlc

VPH (Aliphatics/Aromatics) Laboratory Reporting Form

Client Name: Richard Catlin & Associates

Project Name: PP-3332

Sample Information and Analytical Results	
Sample Identification	USTPP3332-SB03 (1-2)
Sample Matrix	Soil
Collection Option (for Soil)*	3
Date Collected	03/25/03
Date Received	03/25/03
Date Extracted	03/25/03
Date Analyzed	03/29/03
Dry Weight	89
Dilution Factor	1
C <sub>5</sub> -C <sub>8</sub> Aliphatics**	< 10 (mg/Kg)
C <sub>9</sub> -C <sub>12</sub> Aliphatics**	< 10 (mg/Kg)
C <sub>9</sub> -C <sub>10</sub> Aromatics**	< 10 (mg/Kg)
Surrogate % Recovery - PID	90
Surrogate % Recovery - FID	110

\* = Option 1 = Established fill line on vial, Option 2 = Sampling Device/Brand, or Option 3 = Field weight of soil.

\*\* = Excludes any surrogates or internal standards.

Lab Info: G128-1082-66355

Reviewed By: mke

**VPH (Aliphatics/Aromatics) Laboratory Reporting Form**

Client Name: Richard Catlin & Associates

Project Name: PP-3332

Sample Information and Analytical Results	
Sample Identification	USTPP3332-SB04 (1-2)
Sample Matrix	Soil
Collection Option (for Soil)*	3
Date Collected	03/25/03
Date Received	03/25/03
Date Extracted	03/25/03
Date Analyzed	03/29/03
Dry Weight	92
Dilution Factor	1
C <sub>5</sub> -C <sub>8</sub> Aliphatics**	< 10 (mg/Kg)
C <sub>9</sub> -C <sub>12</sub> Aliphatics**	< 10 (mg/Kg)
C <sub>9</sub> -C <sub>10</sub> Aromatics**	< 10 (mg/Kg)
Surrogate % Recovery - PID	87
Surrogate % Recovery - FID	110

\* = Option 1 = Established fill line on vial, Option 2 = Sampling Device/Brand, or Option 3 = Field weight of soil.  
 \*\* = Excludes any surrogates or internal standards.

Lab Info: G128-1082-66356

Reviewed By: MILC

PARADIGM ANALYTICAL LABORATORIES, INC.

Attachment 2

VPH Laboratory Reporting Form

Calibration and QA/QC Information

FID Initial Calibration Date: 12/26/02 PID Initial Calibration Date: 12/26/02

**Calibration Ranges and Limits**

Range	MDL		ML		RL	
	(µg/L)	(mg/Kg)	(µg/L)	(mg/Kg)	(µg/L)	(mg/Kg)
C <sub>5</sub> -C <sub>8</sub> Aliphatics	9.3	0.41	29.4	1.3	100	10
C <sub>9</sub> -C <sub>12</sub> Aliphatics	7.9	0.3	25.2	0.97	100	10
C <sub>9</sub> -C <sub>10</sub> Aromatics	0.5	0.04	1.5	0.14	100	10

**Calibration Concentration Levels**

Range	Levels		%RSD or CCC	Method of Quantitation
	(µg/L)	(mg/Kg)		
C <sub>5</sub> -C <sub>8</sub> Aliphatics	20	2	4.0	Calibration Factor
	80	8		
	200	20		
	800	80		
	2000	200		
C <sub>9</sub> -C <sub>12</sub> Aliphatics	15	1.5	12.3	Calibration Factor
	60	6		
	150	15		
	600	60		
	1500	150		
C <sub>9</sub> -C <sub>10</sub> Aromatics	32.5	3.25	11.3	Calibration Factor
	130	13		
	325	32.5		
	1300	130		
	3250	325		

Calibration Check Date: 03/28/03

**Calibration Check**

Range	Levels		RPD
	(µg/L)	(mg/Kg)	
C <sub>5</sub> -C <sub>8</sub> Aliphatics	200	20	-0.7
C <sub>9</sub> -C <sub>12</sub> Aliphatics	150	15	11.5
C <sub>9</sub> -C <sub>10</sub> Aromatics	325	32.5	-1.4

MDL = Method Detection Limit

ML = Minimum Limit

RL = Reportable Limit

RPD = Relative Percent Difference

%RSD = Percent Relative Standard Deviation

CCC = Correlation Coefficient of Curve

Reviewed By: mw

N.C. Certification #481 S.C. Certification #99029

**PARADIGM ANALYTICAL LABORATORIES, INC.**

**Results for Semivolatiles**

by GCMS 8270

Client Sample ID: USTPP3332-SB02 (1-2)

Date Collected: 3/25/2003

Client Project ID: PP-3332

Date Received: 3/25/2003

Lab Sample ID: 66354

Date Analyzed: 3/31/2003

Lab Project ID: G128-1082

Analyzed By: MRC

Matrix: Soil

%Solids: 82.5

Dilution: 1

<b>Compound</b>	<b>Quantitation Limit (mg/KG)</b>	<b>Result (mg/KG)</b>
Acenaphthene	0.38	BQL
Acenaphthylene	0.38	BQL
Anthracene	0.38	BQL
Benzo[a]anthracene	0.38	BQL
Benzo[a]pyrene	0.38	BQL
Benzo[b]fluoranthene	0.38	BQL
Benzo[g,h,i]perylene	0.38	BQL
Benzo[k]fluoranthene	0.38	BQL
Benzoic Acid	0.76	0.64 J
Bis(2-chloroethoxy)methane	0.38	BQL
Bis(2-chloroethyl)ether	0.38	BQL
Bis(2-chloroisopropyl)ether	0.38	BQL
Bis(2-ethylhexyl)phthalate	0.38	BQL
4-bromophenyl phenyl ether	0.38	BQL
Butylbenzylphthalate	0.38	BQL
4-Chloroaniline	1.9	BQL
4-Chloro-3-methylphenol	0.38	BQL
2-Chloronaphthalene	0.38	BQL
2-Chlorophenol	0.38	BQL
4-Chlorophenyl phenyl ether	0.38	BQL
Chrysene	0.38	BQL
Di-n-Butylphthalate	0.38	BQL
Di-n-octylphthalate	0.38	BQL
Dibenzo[a,h]anthracene	0.38	BQL
Dibenzofuran	0.38	BQL
1,2-Dichlorobenzene	0.38	BQL
1,3-Dichlorobenzene	0.38	BQL
1,4-Dichlorobenzene	0.38	BQL
3,3'-Dichlorobenzidine	0.76	BQL
2,4-Dichlorophenol	0.38	BQL
Diethylphthalate	0.38	BQL
2,4-Dimethylphenol	0.38	BQL
Dimethylphthalate	0.38	BQL
4,6-Dinitro-2-methylphenol	1.9	BQL
2,4-Dinitrophenol	1.9	BQL
2,4-Dinitrotoluene	0.38	BQL
2,6-Dinitrotoluene	0.38	BQL
Fluoranthene	0.38	BQL
Fluorene	0.38	BQL
Hexachlorobenzene	0.38	BQL

**PARADIGM ANALYTICAL LABORATORIES, INC.**

**Results for Semivolatiles**

by GCMS 8270

Client Sample ID: USTPP3332-SB02 (1-2)

Date Collected: 3/25/2003

Client Project ID: PP-3332

Date Received: 3/25/2003

Lab Sample ID: 66354

Date Analyzed: 3/31/2003

Lab Project ID: G128-1082

Analyzed By: MRC

Matrix: Soil

%Solids: 82.5

Dilution: 1

Compound	Quantitation Limit (mg/KG)	Result (mg/KG)
Hexachlorobutadiene	0.38	BQL
Hexachlorocyclopentadiene	0.76	BQL
Hexachloroethane	0.38	BQL
Indeno(1,2,3-c,d)pyrene	0.38	BQL
Isophorone	0.38	BQL
2-Methylnaphthalene	0.38	BQL
2-Methylphenol	0.38	BQL
3- & 4-Methylphenol	0.38	BQL
N-Nitrosodi-n-propylamine	0.38	BQL
N-Nitrosodiphenylamine	0.38	BQL
Naphthalene	0.38	BQL
2-Nitroaniline	0.38	BQL
3-Nitroaniline	1.9	BQL
4-Nitroaniline	1.9	BQL
Nitrobenzene	0.38	BQL
2-Nitrophenol	0.38	BQL
4-Nitrophenol	1.9	BQL
Pentachlorophenol	1.9	BQL
Phenanthrene	0.38	BQL
Phenol	0.38	BQL
Pyrene	0.38	BQL
1,2,4-Trichlorobenzene	0.38	BQL
2,4,5-Trichlorophenol	0.38	BQL
2,4,6-Trichlorophenol	0.38	BQL

Surrogate Spike Recoveries	Spike Added	Spike Result	Percent Recovered
2-Fluorobiphenyl	10	9.7	97
2-Fluorophenol	10	8.6	86
Nitrobenzene-d5	10	9.3	93
Phenol-d6	10	8.9	89
2,4,6-Tribromophenol	10	11.3	113
4-Terphenyl-d14	10	11.0	110

**Comments:**

Results are corrected for %solids and dilution where applicable.

**Flags:**

BQL = Below Quantitation Limit.

J = Detected below the quantitation limit.

Reviewed By: MRC

N.C. Certification #481 S.C. Certification #99029

PARADIGM ANALYTICAL LABORATORIES, INC.

Results of Library Search for Semivolatile Compounds

by GCMS

Client Sample ID: USTPP3332-SB02 (1-2)

Client Project ID: PP-3332

Lab Sample ID: 66354

Lab Project ID: G128-1082

Matrix: Soil

% SOLIDS: 82.5

Date Collected: 3/25/2003

Date Received: 3/25/2003

Date Analyzed: 3/31/2003

Analyzed By: MRC

Dilution: 1

No.	Compound	Retention Time	CAS#	Match Probability	Result (ug/KG)
1	Alkane, Unknown	22.79			0.53
2	Alkane, Unknown	21.12			0.49
3	Aldehyde, Unknown	9.74			0.39
4	Alkane, Unknown	8.19			0.28
5	Vanillin	11.42	000121-33-5	93	0.27
6	Unknown	6.84			0.24
7	Unknown	15.59			0.16
8					
9					
10					

**Comment:**

Tentatively Identified Compound (TIC) refers to substances which are not present in the list of target compounds. Therefore, not all TICs are identified and quantitated using individual standards. TIC listings are prepared utilizing a computerized library search of electron impact mass spectral data and evaluation of the relevant data by a mass spectral data specialist.

Quantitation is accomplished by relative peak area of the compound compared to that of the nearest internal standard from the total ion chromatogram. TICs are identified and quantitated only if the peak area is equal to or greater than 10% of that of the nearest internal standard. Quantitation provided is an estimate.

Reviewed by: MRC

PARADIGM ANALYTICAL LABORATORIES, INC.

Results for Semivolatiles

by GCMS 8270

Client Sample ID: USTPP3332-SB03 (1-2)

Date Collected: 3/25/2003

Client Project ID: PP-3332

Date Received: 3/25/2003

Lab Sample ID: 66355

Date Analyzed: 3/31/2003

Lab Project ID: G128-1082

Analyzed By: MRC

Matrix: Soil

%Solids: 89.5

Dilution: 1

Compound	Quantitation Limit (mg/KG)	Result (mg/KG)
Acenaphthene	0.35	BQL
Acenaphthylene	0.35	BQL
Anthracene	0.35	BQL
Benzo[a]anthracene	0.35	BQL
Benzo[a]pyrene	0.35	BQL
Benzo[b]fluoranthene	0.35	BQL
Benzo[g,h,i]perylene	0.35	BQL
Benzo[k]fluoranthene	0.35	BQL
Benzoic Acid	0.69	0.38 J
Bis(2-chloroethoxy)methane	0.35	BQL
Bis(2-chloroethyl)ether	0.35	BQL
Bis(2-chloroisopropyl)ether	0.35	BQL
Bis(2-ethylhexyl)phthalate	0.35	BQL
4-bromophenyl phenyl ether	0.35	BQL
Butylbenzylphthalate	0.35	BQL
4-Chloroaniline	1.7	BQL
4-Chloro-3-methylphenol	0.35	BQL
2-Chloronaphthalene	0.35	BQL
2-Chlorophenol	0.35	BQL
4-Chlorophenyl phenyl ether	0.35	BQL
Chrysene	0.35	BQL
Di-n-Butylphthalate	0.35	BQL
Di-n-octylphthalate	0.35	BQL
Dibenzo[a,h]anthracene	0.35	BQL
Dibenzofuran	0.35	BQL
1,2-Dichlorobenzene	0.35	BQL
1,3-Dichlorobenzene	0.35	BQL
1,4-Dichlorobenzene	0.35	BQL
3,3'-Dichlorobenzidine	0.69	BQL
2,4-Dichlorophenol	0.35	BQL
Diethylphthalate	0.35	BQL
2,4-Dimethylphenol	0.35	BQL
Dimethylphthalate	0.35	BQL
4,6-Dinitro-2-methylphenol	1.7	BQL
2,4-Dinitrophenol	1.7	BQL
2,4-Dinitrotoluene	0.35	BQL
2,6-Dinitrotoluene	0.35	BQL
Fluoranthene	0.35	BQL
Fluorene	0.35	BQL
Hexachlorobenzene	0.35	BQL

**PARADIGM ANALYTICAL LABORATORIES, INC.**

**Results for Semivolatiles**

by GCMS 8270

Client Sample ID: USTPP3332-SB03 (1-2)

Date Collected: 3/25/2003

Client Project ID: PP-3332

Date Received: 3/25/2003

Lab Sample ID: 66355

Date Analyzed: 3/31/2003

Lab Project ID: G128-1082

Analyzed By: MRC

Matrix: Soil

%Solids: 89.5

Dilution: 1

Compound	Quantitation Limit (mg/KG)	Result (mg/KG)
Hexachlorobutadiene	0.35	BQL
Hexachlorocyclopentadiene	0.69	BQL
Hexachloroethane	0.35	BQL
Indeno(1,2,3-c,d)pyrene	0.35	BQL
Isophorone	0.35	BQL
2-Methylnaphthalene	0.35	BQL
2-Methylphenol	0.35	BQL
3- & 4-Methylphenol	0.35	BQL
N-Nitrosodi-n-propylamine	0.35	BQL
N-Nitrosodiphenylamine	0.35	BQL
Naphthalene	0.35	BQL
2-Nitroaniline	0.35	BQL
3-Nitroaniline	1.7	BQL
4-Nitroaniline	1.7	BQL
Nitrobenzene	0.35	BQL
2-Nitrophenol	0.35	BQL
4-Nitrophenol	1.7	BQL
Pentachlorophenol	1.7	BQL
Phenanthrene	0.35	BQL
Phenol	0.35	BQL
Pyrene	0.35	BQL
1,2,4-Trichlorobenzene	0.35	BQL
2,4,5-Trichlorophenol	0.35	BQL
2,4,6-Trichlorophenol	0.35	BQL

Surrogate Spike Recoveries	Spike Added	Spike Result	Percent Recovered
2-Fluorobiphenyl	10	9.6	96
2-Fluorophenol	10	8.6	86
Nitrobenzene-d5	10	9.3	93
Phenol-d6	10	8.9	89
2,4,6-Tribromophenol	10	11.0	110
4-Terphenyl-d14	10	11.1	111

**Comments:**

Results are corrected for %solids and dilution where applicable.

**Flags:**

BQL = Below Quantitation Limit.

J = Detected below the quantitation limit.

Reviewed By:   jmrC

**PARADIGM ANALYTICAL LABORATORIES, INC.**

**Results of Library Search for Semivolatile Compounds**  
by GCMS

Client Sample ID: USTPP3332-SB03 (1-2)

Client Project ID: PP-3332

Lab Sample ID: 66355

Lab Project ID: G128-1082

Matrix: Soil

% SOLIDS: 89.5

Date Collected: 3/25/2003

Date Received: 3/25/2003

Date Analyzed: 3/31/2003

Analyzed By: MRC

Dilution: 1

No.	Compound	Retention Time	CAS#	Match Probability	Result (ug/KG)
1	Aromatic, Unknown	18.56			1.9
2	Unknown	23.63			1
3	Unknown	17.61			0.94
4	Unknown	11.00			0.45
5	Alkane, Unknown	21.12			0.42
6	alpha.-Pinene	6.49	000080-56-8	91	0.4
7	Unknown	26.34			0.38
8	Unknown	13.78			0.2
9	Unknown	13.73			0.2
10	Unknown	26.51			0.18

**Comment:**

Tentatively Identified Compound (TIC) refers to substances which are not present in the list of target compounds. Therefore, not all TICs are identified and quantitated using individual standards. TIC listings are prepared utilizing a computerized library search of electron impact mass spectral data and evaluation of the relevant data by a mass spectral data specialist.

Quantitation is accomplished by relative peak area of the compound compared to that of the nearest internal standard from the total ion chromatogram. TICs are identified and quantitated only if the peak area is equal to or greater than 10% of that of the nearest internal standard. Quantitation provided is an estimate.

Reviewed by:           MRC

**PARADIGM ANALYTICAL LABORATORIES, INC.**

**Results for Semivolatiles**

by GCMS 8270

Client Sample ID: USTPP3332-SB04 (1-2)

Client Project ID: PP-3332

Lab Sample ID: 66356

Lab Project ID: G128-1082

Matrix: Soil

%Solids: 91.8

Date Collected: 3/25/2003

Date Received: 3/25/2003

Date Analyzed: 3/31/2003

Analyzed By: MRC

Dilution: 1

Compound	Quantitation Limit (mg/KG)	Result (mg/KG)
Acenaphthene	0.34	BQL
Acenaphthylene	0.34	BQL
Anthracene	0.34	BQL
Benzo[a]anthracene	0.34	BQL
Benzo[a]pyrene	0.34	BQL
Benzo[b]fluoranthene	0.34	BQL
Benzo[g,h,i]perylene	0.34	BQL
Benzo[k]fluoranthene	0.34	BQL
Benzoic Acid	0.68	0.61 J
Bis(2-chloroethoxy)methane	0.34	BQL
Bis(2-chloroethyl)ether	0.34	BQL
Bis(2-chloroisopropyl)ether	0.34	BQL
Bis(2-ethylhexyl)phthalate	0.34	BQL
4-bromophenyl phenyl ether	0.34	BQL
Butylbenzylphthalate	0.34	BQL
4-Chloroaniline	1.7	BQL
4-Chloro-3-methylphenol	0.34	BQL
2-Chloronaphthalene	0.34	BQL
2-Chlorophenol	0.34	BQL
4-Chlorophenyl phenyl ether	0.34	BQL
Chrysene	0.34	BQL
Di-n-Butylphthalate	0.34	BQL
Di-n-octylphthalate	0.34	BQL
Dibenzo[a,h]anthracene	0.34	BQL
Dibenzofuran	0.34	BQL
1,2-Dichlorobenzene	0.34	BQL
1,3-Dichlorobenzene	0.34	BQL
1,4-Dichlorobenzene	0.34	BQL
3,3'-Dichlorobenzidine	0.68	BQL
2,4-Dichlorophenol	0.34	BQL
Diethylphthalate	0.34	BQL
2,4-Dimethylphenol	0.34	BQL
Dimethylphthalate	0.34	BQL
4,6-Dinitro-2-methylphenol	1.7	BQL
2,4-Dinitrophenol	1.7	BQL
2,4-Dinitrotoluene	0.34	BQL
2,6-Dinitrotoluene	0.34	BQL
Fluoranthene	0.34	BQL
Fluorene	0.34	BQL
Hexachlorobenzene	0.34	BQL

**PARADIGM ANALYTICAL LABORATORIES, INC.**

**Results for Semivolatiles**

by GCMS 8270

Client Sample ID: USTPP3332-SB04 (1-2)

Client Project ID: PP-3332

Lab Sample ID: 66356

Lab Project ID: G128-1082

Matrix: Soil

%Solids: 91.8

Date Collected: 3/25/2003

Date Received: 3/25/2003

Date Analyzed: 3/31/2003

Analyzed By: MRC

Dilution: 1

Compound	Quantitation Limit (mg/KG)	Result (mg/KG)
Hexachlorobutadiene	0.34	BQL
Hexachlorocyclopentadiene	0.68	BQL
Hexachloroethane	0.34	BQL
Indeno(1,2,3-c,d)pyrene	0.34	BQL
Isophorone	0.34	BQL
2-Methylnaphthalene	0.34	BQL
2-Methylphenol	0.34	BQL
3- & 4-Methylphenol	0.34	BQL
N-Nitrosodi-n-propylamine	0.34	BQL
N-Nitrosodiphenylamine	0.34	BQL
Naphthalene	0.34	BQL
2-Nitroaniline	0.34	BQL
3-Nitroaniline	1.7	BQL
4-Nitroaniline	1.7	BQL
Nitrobenzene	0.34	BQL
2-Nitrophenol	0.34	BQL
4-Nitrophenol	1.7	BQL
Pentachlorophenol	1.7	BQL
Phenanthrene	0.34	BQL
Phenol	0.34	BQL
Pyrene	0.34	BQL
1,2,4-Trichlorobenzene	0.34	BQL
2,4,5-Trichlorophenol	0.34	BQL
2,4,6-Trichlorophenol	0.34	BQL

Surrogate Spike Recoveries	Spike Added	Spike Result	Percent Recovered
2-Fluorobiphenyl	10	9.7	97
2-Fluorophenol	10	8.5	85
Nitrobenzene-d5	10	9.4	94
Phenol-d6	10	8.9	89
2,4,6-Tribromophenol	10	11.2	112
4-Terphenyl-d14	10	11.0	110

**Comments:**

Results are corrected for %solids and dilution where applicable.

**Flags:**

BQL = Below Quantitation Limit.

J = Detected below the quantitation limit.

Reviewed By: mmu

PARADIGM ANALYTICAL LABORATORIES, INC.

Results of Library Search for Semivolatile Compounds  
by GCMS

Client Sample ID: USTPP3332-SB04 (1-2)

Client Project ID: PP-3332

Lab Sample ID: 66356

Lab Project ID: G128-1082

Matrix: Soil

% SOLIDS: 91.8

Date Collected: 3/25/2003

Date Received: 3/25/2003

Date Analyzed: 3/31/2003

Analyzed By: MRC

Dilution: 1

No.	Compound	Retention Time	CAS#	Match Probability	Result (ug/KG)
1	Unknown	20.11			14
2	Unknown	25.96			1.2
3	Unknown	19.50			0.78
4	Unknown	18.55			0.42
5	Unknown	17.61			0.27
6					
7					
8					
9					
10					

**Comment:**

Tentatively Identified Compound (TIC) refers to substances which are not present in the list of target compounds. Therefore, not all TICs are identified and quantitated using individual standards. TIC listings are prepared utilizing a computerized library search of electron impact mass spectral data and evaluation of the relevant data by a mass spectral data specialist.

Quantitation is accomplished by relative peak area of the compound compared to that of the nearest internal standard from the total ion chromatogram. TICs are identified and quantitated only if the peak area is equal to or greater than 10% of that of the nearest internal standard. Quantitation provided is an estimate.

Reviewed by: MRC

**EPH (Aliphatics/Aromatics) Results**

by MDEP-EPH

Client Name: Richard Catlin & Associates

Project Name: PP-3332

Sample Information and Analytical Results	
Sample Identification	USTPP3332-SB02 (1-2)
Sample Matrix	Soil
Date Collected	03/25/03
Date Received	03/25/03
Date Extracted	03/27/03
Date Analyzed	03/31/03
Dry Weight	82.5
Dilution Factor	1
C <sub>9</sub> -C <sub>18</sub> Aliphatics*	< 10 (mg/Kg)
C <sub>19</sub> -C <sub>36</sub> Aliphatics*	< 10 (mg/Kg)
C <sub>11</sub> -C <sub>22</sub> Aromatics*	< 10 (mg/Kg)
Aliphatic Surrogate % Recovery	95
Aromatic Surrogate % Recovery	95

**Comments:**

\* = Excludes any surrogates or internal standards.  
 Sample did not require fractionation.

Lab info: G128-1082-66354

Reviewed By: mac

**EPH (Aliphatics/Aromatics) Results**

by MDEP-EPH

Client Name: Richard Catlin & Associates

Project Name: PP-3332

Sample Information and Analytical Results	
Sample Identification	USTPP3332-SB03 (1-2)
Sample Matrix	Soil
Date Collected	03/25/03
Date Received	03/25/03
Date Extracted	03/27/03
Date Analyzed	03/28/03
Dry Weight	89.5
Dilution Factor	1
C <sub>9</sub> -C <sub>18</sub> Aliphatics*	< 10 (mg/Kg)
C <sub>19</sub> -C <sub>36</sub> Aliphatics*	< 10 (mg/Kg)
C <sub>11</sub> -C <sub>22</sub> Aromatics*	< 10 (mg/Kg)
Aliphatic Surrogate % Recovery	85
Aromatic Surrogate % Recovery	84

**Comments:**

\* = Excludes any surrogates or internal standards.  
 Sample did not require fractionation.

Lab info: G128-1082-66355

Reviewed By: MLC

**EPH (Aliphatics/Aromatics) Results**

by MDEP-EPH

Client Name: Richard Catlin & Associates

Project Name: PP-3332

Sample Information and Analytical Results	
Sample Identification	USTPP3332-SB04 (1-2)
Sample Matrix	Soil
Date Collected	03/25/03
Date Received	03/25/03
Date Extracted	03/27/03
Date Analyzed	03/31/03
Dry Weight	91.8
Dilution Factor	1
C <sub>9</sub> -C <sub>18</sub> Aliphatics*	< 10 (mg/Kg)
C <sub>19</sub> -C <sub>36</sub> Aliphatics*	< 10 (mg/Kg)
C <sub>11</sub> -C <sub>22</sub> Aromatics*	< 10 (mg/Kg)
Aliphatic Surrogate % Recovery	94
Aromatic Surrogate % Recovery	94

**Comments:**

\* = Excludes any surrogates or internal standards.  
 Sample did not require fractionation.

Lab info: G128-1082-66356

Reviewed By: MAC

**PARADIGM ANALYTICAL LABORATORIES, INC.**

Attachment 3

**EPH Laboratory Reporting Form**

<b>Calibration and QA/QC Information</b>
--

Initial Calibration Date: 03/19/03

**Calibration Ranges and Limits**

Range	MDL		ML		RL	
	(mg/Kg)	(µg/L)	(mg/Kg)	(µg/L)	(mg/Kg)	(µg/L)
C <sub>9</sub> -C <sub>18</sub> Aliphatics	0.1	0.8	0.3	2.6	100	10
C <sub>19</sub> -C <sub>36</sub> Aliphatics	0.1	1.6	0.3	5	100	10
C <sub>11</sub> -C <sub>22</sub> Aromatics	0.2	2.1	0.6	6.7	100	10

**Calibration Concentration Levels**

Range	Levels		%RSD or CCC	Method of Quantitation
	(µg/L)	(mg/Kg)		
C <sub>9</sub> -C <sub>18</sub> Aliphatics	0.06	1	5.00	Calibration Factor
	0.15	2.5		
	0.3	5		
	0.6	10		
	1.2	20		
C <sub>19</sub> -C <sub>36</sub> Aliphatics	0.08	1.33	2.4	Calibration Factor
	0.2	3.33		
	0.4	6.67		
	0.8	13.3		
	1.6	26.7		
C <sub>11</sub> -C <sub>22</sub> Aromatics	0.17	2.83	1.3	Calibration Factor
	0.425	7.08		
	0.85	14.2		
	1.7	28.3		
	3.4	56.7		

Calibration Check Date: 03/28/03

**Calibration Check**

Range	Levels		RPD
	(µg/mL)	(mg/Kg)	
C <sub>9</sub> -C <sub>18</sub> Aliphatics	0.6	10	3.7
C <sub>19</sub> -C <sub>36</sub> Aliphatics	0.8	13.3	2.0
C <sub>11</sub> -C <sub>22</sub> Aromatics	1.7	28.3	-2.6

MDL = Method Detection Limit

ML = Minimum Limit

RL = Reportable Limit

RPD = Relative Percent Difference

%RSD = Percent Relative Standard Deviation

CCC = Correlation Coefficient of Curve

**PARADIGM ANALYTICAL LABORATORIES, INC.**

Attachment 3

**EPH Laboratory Reporting Form**

<b>Calibration and QA/QC Information</b>
--

Initial Calibration Date: 03/19/03

**Calibration Ranges and Limits**

Range	MDL		ML		RL	
	(mg/Kg)	(µg/L)	(mg/Kg)	(µg/L)	(mg/Kg)	(µg/L)
C <sub>9</sub> -C <sub>18</sub> Aliphatics	0.1	0.8	0.3	2.6	100	10
C <sub>19</sub> -C <sub>36</sub> Aliphatics	0.1	1.6	0.3	5	100	10
C <sub>11</sub> -C <sub>22</sub> Aromatics	0.2	2.1	0.6	6.7	100	10

**Calibration Concentration Levels**

Range	Levels		%RSD or CCC	Method of Quantitation
	(µg/L)	(mg/Kg)		
C <sub>9</sub> -C <sub>18</sub> Aliphatics	0.06	1	5.00	Calibration Factor
	0.15	2.5		
	0.3	5		
	0.6	10		
	1.2	20		
C <sub>19</sub> -C <sub>36</sub> Aliphatics	0.08	1.33	2.4	Calibration Factor
	0.2	3.33		
	0.4	6.67		
	0.8	13.3		
	1.6	26.7		
C <sub>11</sub> -C <sub>22</sub> Aromatics	0.17	2.83	1.3	Calibration Factor
	0.425	7.08		
	0.85	14.2		
	1.7	28.3		
	3.4	56.7		

Calibration Check Date: 03/31/03

**Calibration Check**

Range	Levels		RPD
	(µg/mL)	(mg/Kg)	
C <sub>9</sub> -C <sub>18</sub> Aliphatics	0.6	10	3.1
C <sub>19</sub> -C <sub>36</sub> Aliphatics	0.8	13.3	3.3
C <sub>11</sub> -C <sub>22</sub> Aromatics	1.7	28.3	-1.6

MDL = Method Detection Limit

ML = Minimum Limit

RL = Reportable Limit

RPD = Relative Percent Difference

%RSD = Percent Relative Standard Deviation

CCC = Correlation Coefficient of Curve

Client: CATLIN Project ID: PP-3332 Date: 3/25/03 Report To: MIKE E. MASON @ CATLIN  
 Address: 220 OLD DIARY ROAD Contact: MIKE E. MASON Turnaround: STANDARD  
 Address: Wilmington, NC 28405 Phone: 452-5861 Job Number: 203-016-38  
 Note #: DOD 101 Fax: 452-7563 P.O. Number: 230130-6 Invoice To: Shiela @ CATLIN

Sample ID	Date	Time	Matrix	Preservatives				Analyses				Comments: Please specify any special reporting requirements	
				ICE	Methanol	Sodium Bisulfate		B2LO+I+RET MTBE	VPH	B270+10 101+070/101 101+070/101	EPH		
STPP 3332- B02 (1-2)	3/25/03	0750	Soil	+	+	+		+	+	+	+		
STPP 3332- B03 (1-2)	3/25/03	0800	Soil	+	+	+		+	+	+	+		G128-1082
STPP 3332- B04 (1-2)	3/25/03	0815	Soil	+	+	+		+	+	+	+		
STPP 3332- B04 D (1-2)	3/25/03	0815	Soil	+	+	+		+					
	24 GDC												

Relinquished By	Date	Time	Received By	Date	Time	Temperature	State Certification Requested
<i>Jahli Caswell</i>	3/25/03	0940	<i>Jahli Caswell</i>	3/25/03	0940	ON ICE 4.4°C	NC <input checked="" type="checkbox"/> SC <input type="checkbox"/> Other <input type="checkbox"/>

SEE REVERSE FOR TERMS AND CONDITIONS

**APPENDIX F**  
**UST CLOSURE SAMPLING RESULTS**



Table SOIL SAMPLES ANALYTICAL RESULTS

SAMPLE ID	DATE	SAMPLE DEPTH																							
			C9-C22 Aromatics	C5-C8 Aliphatics	C9-C18 Aliphatics	C19-C36 Aliphatics	Fluorene	Sec-Butylbenzene	Ethylbenzene	Isopropylbenzene	4-Isopropyltoluene	Naphthalene	N-Propylbenzene	1,2,4-Trimethylbenzene	1,3,5-Trimethylbenzene	1-Methylnaphthalene	2-Methylnaphthalene	Phenanthrene	Dibenzofuran	Acenaphthene	Toluene	Pyrene	Methylene chloride	Total Xylenes	
CC-3332-1	11/5/01	4'	<b>3900</b>	670	9160	150	11	7.3	5.2	3.1	6.3	49	6.3	62	20	70	<b>120</b>	18	4.8	4.4					30.2
CC-3332-2	11/5/01	4'	<b>1640</b>	66	1770	67	3.8						35		8.2	25	2.2	7.2	1.2	2.2		0.79			
CC-3332-3	11/5/01	4'	<b>1670</b>	84	1600	83	4.6	1.2			1.3	13		7.5	3.3	26	40	7	1.6	1.8					3.1
CC-3332-4	11/5/01	4'	<b>3170</b>	430	3820	160	12	9.1	5.9	3.5	8.4	56	7.4	76	26	69	<b>110</b>	19	4.4	4.6					32.6
CC-3332-5	11/5/01	6'							0.0098				0.047		0.022	0.0063					0.02		0.038	0.05	
Residential Soil Cleanup Level	--		469	939	9386	93860	620	156	1560	1564	n/e	63	156	782	782	n/e	63	469	62	940	3200	469	85	32000	
Soil-to-Water Maximum Soil Contaminant Concentration	--		34	72	3255		44	3	0.24	2	n/e	0.58	2	8	7	n/e	3	60	4.7	8	7	286	0.02	5	

- Note:
1. Only those compounds whose concentration is above Method Detection Limit are listed
  2. A no-entry-cell indicates compound concentration Below Method Detection Limit
  3. n/e ---- Not established yet by NCDENR
  4. Bold indicates compound concentration above Residential Soil Cleanup Level