

Soil Contamination Report (for Petroleum Releases Only)

A. Site Identification

DATE OF REPORT: 22 September 2005

Site Name: Campbell Street Fuel Farm

Nearest City/Town: MCAS, New River

County: Onslow

UST Owner: Commanding General

Address: PSC Box 20004, MCB, Camp Lejeune, NC 28542

Phone: 910-451-9660

UST Operator: MCAS New River Fuels Officer

Address: Bldg AS148, White Street

Phone: 910-449-6694

Release Information

Date Discovered: 15 August 2005

Latitude: 34° 43' 13" N

Longitude: 77° 27' 09" W

Estimated Quantity of Release: 200 Gallons

Cause of Release: Sample port left open when delivery was made to Tank 2

Source of Release (Piping/UST): Piping

Sizes and contents of Aboveground Storage Tank (AST) system(s) from which the release occurred):

Tank 2: 215,000 Gallons

Complete and include as Attachments items B through E in the order listed.

I, William Carl Morris, Jr., a Professional Engineer/Licensed Geologist (circle one) for Engineering and Environment, Inc. (EEI), do certify that the information contained in this report is correct and accurate to the best of my knowledge.

9-22-05

(Please Affix Seal and Signature)

B. Site Investigation

1. Describe all soil sampling performed to date (use maps and tables whenever possible) and include:
 - ☐ location of soil samples;
 - ☐ type of soil samples (from excavation, borehole, geoprobe, etc.);
 - ☐ Complete and attach Table 3.

Soil samples were collected from the sidewalls of the excavation advanced on 16 and 17 August 2005. A total of four samples were collected. The attached Figure 2 illustrates the approximate limits of the excavation, soil sample locations, soil sample depths, and soil sample analytical results. The attached Table 3 summarizes the soil sample analytical results.

2. Describe any groundwater sampling performed to date. Use maps and tables whenever possible and include:
 - ☐ location of groundwater samples/monitoring wells/water supply wells;
 - ☐ Complete and attach Table 4.

Groundwater samples were not collected as part of this investigation. Several monitoring wells exist at the site; wells located in the immediate vicinity of the excavation are illustrated on Figure 2. Recent groundwater quality data from nearby wells are summarized in the attached Table 4.

3. Describe any excavation, treatment and/or disposal of contaminated soil.

Late on 15 August 2005, a fuel sample port was discovered in an open position, from which an estimated 200 gallons of JP-5 jet fuel reportedly was released prior to the discovery and subsequent closing of the port. EEI received notification of the release the morning of 16 August and mobilized to the site that morning.

Excavation activities were initiated the afternoon of 16 August 2005 and continued uninterrupted into the early morning of 17 August 2005. Soils were excavated using a small backhoe. Horizontal excavation limits corresponded to an area where ground surface appeared visually stained. Vertically, the excavation was extended to a depth of approximately four feet below ground surface (bgs) throughout most of the area, corresponding to the maximum reach of the backhoe, and a depth at which little or no visible staining was evident on the base of the excavation. At the north end of the excavation, the base of the excavation was sloped from approximately four feet bgs upwards to ground surface. Along the east-central portion of the area, excavation was conducted to a depth of approximately two-feet bgs as site structures limited the access and reach of the backhoe. In the southern portion of the area, a concrete pad was present, and surface material (approximately four inches of gravel) was removed with shovels, exposing hard-packed soil overlying the pad; the pad was not disturbed during the activities. Figure 2 illustrates the approximate extent of the excavation, including estimated depths of the excavation.

Excavated soils were stockpiled at the site and placed on plastic sheeting, then covered with plastic sheeting. Sand bags were used to secure the sheeting to limit exposure of the stockpiled soil. An estimated 30 cubic yards of soil were excavated and stockpiled.

Upon completion of the excavation, four soil samples were collected from the base and sidewalls of the excavation (Figure 2). Samples were collected with a steel-bladed shovel; larger, relatively undisturbed soil clumps from the shovel blade were packed in laboratory-supplied sample containers. Samples were labeled, placed in an iced cooler, and transported under chain-of-custody by EEI directly to Paradigm Analytical Laboratories, Inc.'s Wilmington, North Carolina facility. All samples were analyzed for Gasoline Range Organics and Diesel Range Organics under an expedited (24-hour) turn-around basis. Soil sample analytical results are summarized in Table 3; the laboratory analytical report is included as an attachment.

The shovel used to collect the soil samples was decontaminated before first use and between each use. Decontamination included washing the shovel blade in a solution of potable water and Liquinox (a laboratory grade detergent), rinsing in potable water, and final rinsing in deionized water.

Once soil sampling had been completed, the excavation was backfilled with clean soil. As soil was placed into the excavation, it was compacted by tamping the soil with the backhoe bucket and repeatedly driving the backhoe over the emplaced soil. Backfilling was conducted until the soil level approximately matched the surrounding ground

surface level. Sod was placed over the backfilled soil. Clean gravel was placed above the concrete pad in the southern portion of the area.

C. Figures

- ☐ 7½ minute United States Geographical Survey (USGS) topographic quadrangle map (copy) with site location identified and showing an area within 1,500-foot radius of source of release.
- ☐ Site map with Aboveground Storage Tank (AST) system location(s) including piping and pump islands, site boundaries, buildings, named roads, subsurface utilities, basements, adjacent properties, and any on-site water supply well, ditches, or adjoining surface waters.
- ☐ Site map showing the results of all soil sampling conducted. Indicate sample identifications, sample locations, sampling depths, and analytical results.
- ☐ Site map showing the results of all groundwater sampling conducted. Indicate sample identifications, sample locations/monitoring well identifications, and analytical results.

Figure 1 presents the site location overlain on a USGS topographic map. A circle of 1,500-foot radius centered on the site is included on the figure. No active water supply wells are present within 1,500 feet of the site (Remedial Action Optimization and Revised Corrective Action Plan, Campbell Street Fuel Farm, Marine Corps Air Station New River, North Carolina, 9 May 2005, Catlin Engineers and Scientists).

Figure 3 identifies relevant site structures (e.g., AST systems, buildings, roads, etc.). There are no water supply wells at the site.

Figure 2 identifies the approximate limits of the excavation. Soil sample locations and depths are presented on the figure.

Figure 3 presents the location of nearby existing monitoring wells. Groundwater samples were not collected as part of this investigation.

NOTE: *If possible, use a single base map to prepare site plans using a map scale of 1 inch = 40 feet (or a smaller scale for large sites, if necessary). Maps and figures should include conventional symbols, notations, labeling, legends, scales, and north arrows and should conform to generally accepted practices of map presentation such as those enumerated in the USGS Geological Survey pamphlet, "Topographic Maps."*

D. Tables

- ☐ Site history (Tables 1 and 2);
- ☐ Soil sampling results (Table 3); and
- ☐ Groundwater sampling results (Table 4).

Tables 1 and 2 respectively provide construction and ownership data for the ASTs.

Table 3 summarizes laboratory results for soil samples collected as part of this investigation.

Groundwater samples were not collected as part of this investigation. Available recent groundwater quality data for several existing monitoring wells located near the excavation are included in Table 4.

E. Other Information

- ☐ Boring logs and lithologic descriptions;
- ☐ Well construction records (Table 5);
- ☐ Field measurements (e.g., pH, dissolved oxygen, specific conductivity, temperature) made during groundwater sampling;
- ☐ Standard procedures used for sampling, field equipment decontamination, field screening, etc.;
- ☐ Disposal manifests; and
- ☐ Laboratory reports and chain-of-custody documents.

A lithologic log was not maintained during the excavation activities.

Available well construction records for existing monitoring wells located near the excavation are included in Attachment A. Table 5 summarizes the monitoring well construction data.

Groundwater sampling was not conducted during this investigation.

Methods employed during the investigation are described above.

Excavated soil was stockpiled at the site. Soil removal was not conducted as part of this investigation.

The laboratory report and chain-of-custody are included in Attachment B.

FIGURES

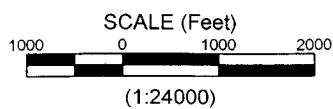
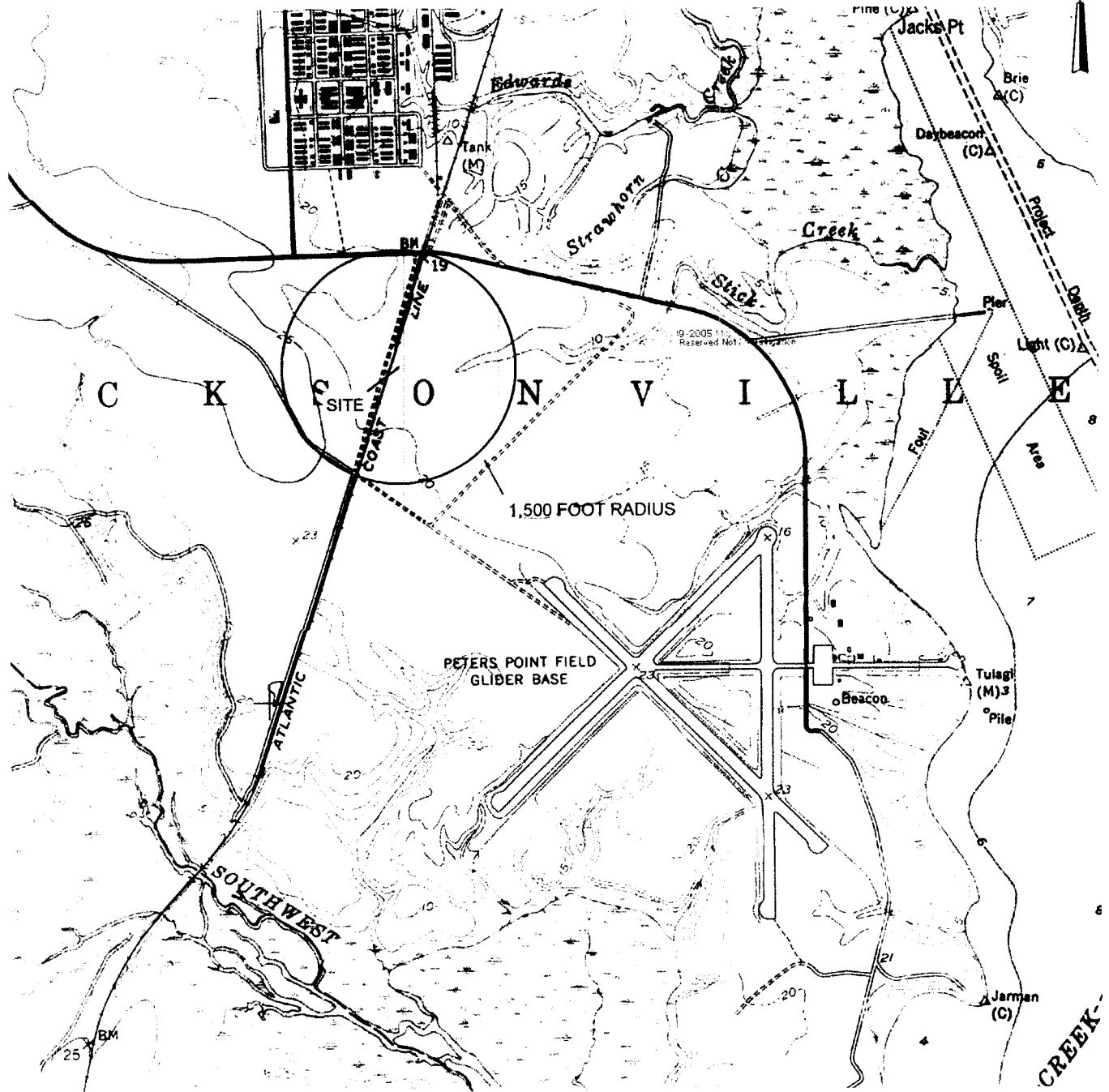
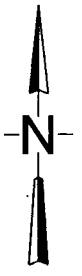
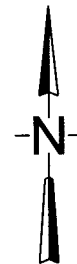

	FIGURE	1	SITE LOCATION CAMPBELL STREET FUEL FARM SITE SOIL CONTAMINATION REPORT MCAS NEW RIVER, NC
	DATE	9/14/05	
	REVISION	0	
	DRAWN BY	AER	
	FILE	CSFF-SCR-TOPO	

U.S.G.S TOPOGRAPHIC MAP:
JACKSONVILLE SOUTH, N.C.



APPROXIMATE
LIMITS OF
SEPTEMBER 2005
EXCAVATION

EXCAVATION
SLOPES
NORTHWARD
TO GROUND
SURFACE

S0004
(~1.5')
GRO: 647 MG/KG
DRO: 21,200 MG/KG

EXCAVATION DEPTH: ~ 4 FEET

S0003
(~1.5')
GRO: 6.7 MG/KG
DRO: 31.1 MG/KG

EXCAVATION DEPTH:
~2 FEET

S0002
(~1')
GRO: 376 MG/KG
DRO: 2770 MG/KG

ESTIMATED POINT
OF FUEL RELEASE

S0001
(~0.3')
GRO: 205 MG/KG
DRO: 4020 MG/KG

EXCAVATION DEPTH:
~0.3 FOOT

PUMP STATION

LEGEND

- ⊗ SOIL SAMPLE LOCATION
- S0004 SOIL SAMPLE NUMBER
- (~1.5') APPROXIMATE SAMPLE DEPTH (FEET BELOW GROUND SURFACE)
- FUEL PIPELINE

GRO: GASOLINE RANGE ORGANICS (10 MG/KG REPORTABLE CONCENTRATION)
DRO: DIESEL RANGE ORGANICS (40 MG/KG REPORTABLE COCNENTRATION)
MG/KG: MILLIGRAMS PER KILOGRAM

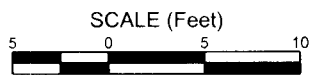
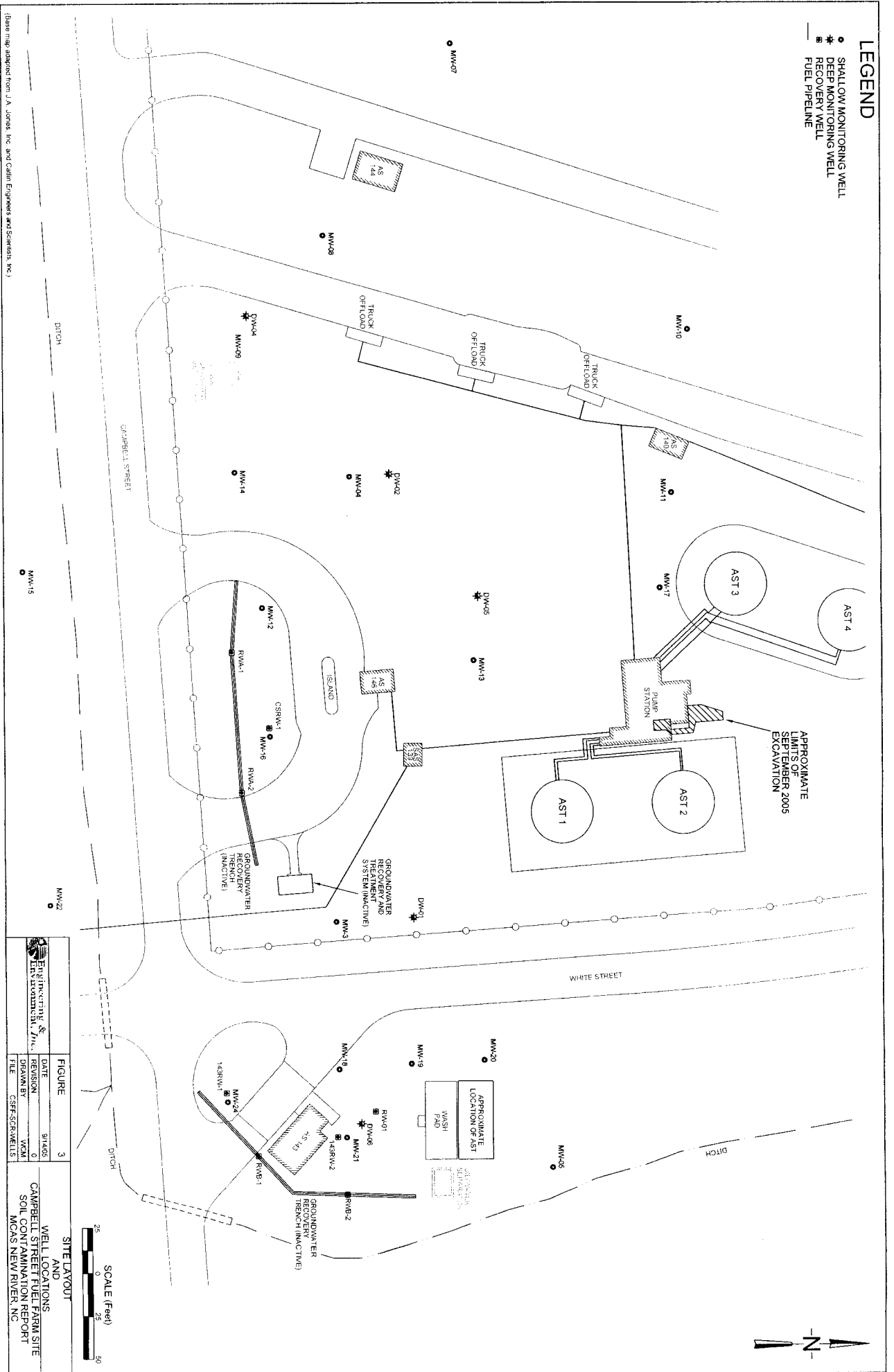

	FIGURE	2	EXCAVATION LIMITS AND SOIL SAMPLE LOCATIONS CAMPBELL STREET FUEL FARM SITE SOIL CONTAMINATION REPORT MCAS NEW RIVER, NC
	DATE	9/14/05	
	REVISION	0	
	DRAWN BY	WCM	
	FILE	CSFF-EXCAVATE	

LEGEND

- SHALLOW MONITORING WELL
- ★ DEEP MONITORING WELL
- RECOVERY WELL
- FUEL PIPELINE



TABLES

Table 1
Summary of Above Ground Storage Tank Construction Data
Campbell Street Fuel Farm

AST ID Number	Product Type	Capacity (gallons)	Date Installed	Date Permanently Closed (P) or Still in Use (C)	Release Associated with AST System? (Yes/No)
1	JP-5	215,500	1985	C	No
2	JP-5	215,500	1985	C	Yes*
3	JP-5	215,500	1985	C	No
4	JP-5	215,500	1985	C	No

* Release occurred at a fuel sample port installed on piping connected to the tank
 AST: Aboveground storage tank

Table 2
Summary of Above Ground Storage Tank Ownership Data
Campbell Street Fuel Farm

AST ID Number	Name of Owner or Operator	Dates of Ownership / Opertaion	Owner or Operator?
1	Commanding General, MCB Camp Lejeune, North Carolina	1985 to Present	Owner
2	Commanding General, MCB Camp Lejeune, North Carolina	1985 to Present	Owner
3	Commanding General, MCB Camp Lejeune, North Carolina	1985 to Present	Owner
4	Commanding General, MCB Camp Lejeune, North Carolina	1985 to Present	Owner

AST: Aboveground storage tank

Table 3
Summary of Laboratory Analyses for Soil
Campbell Street Fuel Farm
17 August 2005

Sample Identification	Approximate Sample Depth (ft bgs)	Gasoline Range Organics (mg/kg)	Diesel Range Organics (mg/kg)
S001	0.3	205	4,020
S002	1.0	376	2,770
S003	1.5	6.7	31.1
S004	1.5	647	21,200
Reportable Concentration		10	40

ft bgs: feet below ground surface

mg/kg: milligrams per kilogram

Shading indicates sample concentration exceeds reportable concentration

Table 4
Summary of Laboratory Analyses for Groundwater
Campbell Street Fuel Farm
June 2005

Sample Location Date Sampled	NCGWQS	MW-03 06/22/05	MW-11 06/22/05	MW-12 06/22/05	MW-14 06/22/05	MW-16 06/22/05	MW-21 06/21/05	MW-24 06/21/05	DW-02 06/22/05	DW-06 06/21/05
EPA 602 (ug/L)										
Benzene	1	<1.0	<1.0	<1.0	<1.0	49.6	58.4	130	<1.0	<1.0
Ethylbenzene	29	<1.0	<1.0	<1.0	<1.0	7.0	4.3	45.3	<1.0	<1.0
Toluene	1000	<1.0	<1.0	0.71 J	<1.0	<1.0	2.8	15.6	<1.0	<1.0
Xylenes (total)	530	<3.0	<3.0	<1.0	<3.0	20.4	7.3	182	<3.0	<3.0
Methyl Tert Butyl Ether	200	<1.0	<1.0	<1.0	<1.0	<1.0	139 E	21.1	<1.0	<1.0
Total BTEX	ND	ND	ND	0.71	ND	77.0	72.8	372.9	ND	ND
EPA 610 (ug/L)										
Acenaphthene	80	NA	NA	NA	NA	NA	NA	NA	12.9	<5.1
Acenaphthylene	210	NA	NA	NA	NA	NA	NA	NA	<5.0	<5.1
Anthracene	2100	NA	NA	NA	NA	NA	NA	NA	<5.0	<5.1
Benzo(a)anthracene	0.05	NA	NA	NA	NA	NA	NA	NA	<5.0	<5.1
Fluoranthene	280	NA	NA	NA	NA	NA	NA	NA	<5.0	<5.1
Fluorene	280	NA	NA	NA	NA	NA	NA	NA	10.7	<5.1
1-Methylnaphthalene	RL	NA	NA	NA	NA	NA	NA	NA	<5.0	<5.1
2-Methylnaphthalene	14	NA	NA	NA	NA	NA	NA	NA	<5.0	<5.1
Naphthalene	21	NA	NA	NA	NA	NA	NA	NA	<5.0	<5.1
Phenanthrene	210	NA	NA	NA	NA	NA	NA	NA	18.8	<5.1
Pyrene	210	NA	NA	NA	NA	NA	NA	NA	<5.0	<5.1
EPA 504.1 (ug/L)										
1,2-Dibromoethane	RL	<0.020	<0.020	<0.020	<0.020	<0.020	<0.020	<0.020	<0.020	<0.020

mg/L: micrograms per liter

<#: not detected at the indicated reporting limit

J: estimated concentration less than reporting limit

E: Concentration exceeds calibration range

NA: Not Analyzed; constituent not included in analytic suite

ND: Not detected; no benzene, toluene, ethylbenzene, or xylene isomers were detected

RL: Reporting Limit, no NCGWQS established for the constituent; therefore, the NCGWQS for the constituent is the reporting limit

NCGWQS: North Carolina Groundwater Quality Standard

Bold type indicates detectable concentrations.

Shaded area indicates detectable concentration above the NCGWQS

Table 5
Summary of Monitoring Well Construction Details and
Gauging Data for 5 August 2005 Laboratory Analyses for Groundwater
Campbell Street Fuel Farm

Well Number	Date Installed	Outer Casing Depth (ft bgs)	Inner Casing Depth (ft bgs)	Screened Interval (ft bgs)	Total Well Depth (ft bgs)	Top of Casing Elevation (ft msl)	Depth to Water (ft btoc)	Depth to Product (ft btoc)	Product Thickness (ft)	Groundwater Elevation* (ft msl)
MW-03	12/12/91	n/a	4.0	4.0 to 13.8	14.0	21.69	6.00	NP	NP	15.69
MW-04	12/13/91	n/a	4.0	4.0 to 13.8	14.0	22.77	nm	nm	nm	nm
MW-05	12/12/91	n/a	5.3	5.3 to 14.7	15.1	23.85	nm	nm	nm	nm
MW-07	12/13/91	n/a	4.0	4.0 to 13.8	14.0	21.04	nm	nm	nm	nm
MW-08	11/19/92	n/a	2.9	2.9 to 12.4	13.0	20.45	nm	nm	nm	nm
MW-09	11/19/92	n/a	3.9	3.9 to 13.5	14.0	20.45	5.23	NP	NP	15.22
MW-10	11/19/92	n/a	4.9	4.9 to 14.4	15.0	21.17	6.10	NP	NP	15.07
MW-11	11/18/92	n/a	5.9	5.9 to 15.5	16.0	22.03	6.00	NP	NP	16.03
MW-12	11/19/92	n/a	3.9	3.9 to 13.5	14.0	21.41	6.53	NP	NP	14.88
MW-13	11/20/92	n/a	4.9	4.9 to 14.5	15.0	22.80	nm	nm	nm	nm
MW-14	11/20/92	n/a	3.1	3.1 to 12.6	13.0	20.07	5.32	NP	NP	14.75
MW-15	11/21/92	n/a	5.9	5.9 to 15.4	16.0	21.08	4.93	NP	NP	16.15
MW-16	11/20/92	n/a	4.9	4.9 to 14.5	15.0	21.45	5.02	NP	NP	16.43
MW-17	11/20/92	n/a	3.2	3.2 to 12.7	13.0	22.51	nm	nm	nm	nm
MW-18	11/22/92	n/a	3.1	3.1 to 12.7	13.0	18.69	nm	nm	nm	nm
MW-19	11/23/92	n/a	4.1	4.1 to 13.6	14.0	19.10	nm	nm	nm	nm
MW-20	11/23/92	n/a	4.6	4.6 to 14.1	14.5	19.40	nm	nm	nm	nm
MW-21	11/21/92	n/a	3.9	3.9 to 13.5	14.0	21.76	6.82	NP	NP	14.94
MW-22	11/23/92	n/a	2.9	2.9 to 12.5	13.0	21.69	4.95	NP	NP	16.74
MW-24	11/22/92	n/a	2.8	2.8 to 10.8	11.0	21.56	7.00	NP	NP	14.56
DW-01	12/19/92	20	25.0	25.0 to 29.8	30.0	20.79	nm	nm	nm	nm
DW-02	01/07/92	20	25.0	25.0 to 29.8	30.0	22.91	7.01	NP	NP	15.90
DW-04	11/22/92	41	45.6	45.6 to 50.4	51.0	21.07	nm	nm	nm	nm
DW-05	11/19/92	33	37.8	37.8 to 42.5	43.0	22.79	nm	nm	nm	nm
DW-06	12/02/92	32	37.3	37.3 to 42.0	42.5	22.83	7.08	NP	NP	15.75

ft: feet
ft bgs: feet below ground surface
ft btoc: feet below top of casing
ft msl: feet above/below mean sea level
n/a: not applicable; well was installed as a single-cased well
nm: not measured; the indicated location was not designated for gauging
NP: no present; measurable free product was not detected
* Groundwater elevations corrected for free product as needed by adding (0.8 x product thickness) to uncorrected groundwater elevation

ATTACHMENT A
MONITORING WELL CONSTRUCTION LOGS

*(Monitoring Well Construction Logs referenced from the following reports:
Final Site Assessment Report, The Campbell Street Fuel Farm and
UST System AS-143, New River Marine Corps Air Station Jacksonville,
North Carolina, 12 August 1992, Baker Environmental Inc.;
Final Site Assessment Report, Additional Assessment Activities at the
Campbell Street Fuel Farm and UST System AS-143, Marine Corps Air Station
New River Jacksonville, North Carolina, 29 April 1994, Baker Environmental, Inc.)*

ABOVE GRADE TYPE II MONITORING WELL

PROJECT No.: 19013-51-SRM
PROJECT NAME: FUEL FARM
WELL No.: MW-3
DRILLING CO.: ATEC

DATE STARTED: 12-12-91
DATE COMPLETED: 12-12-91
DATE DEVELOPED: 12-14-91
DEVELOPMENT METHOD: PUMP

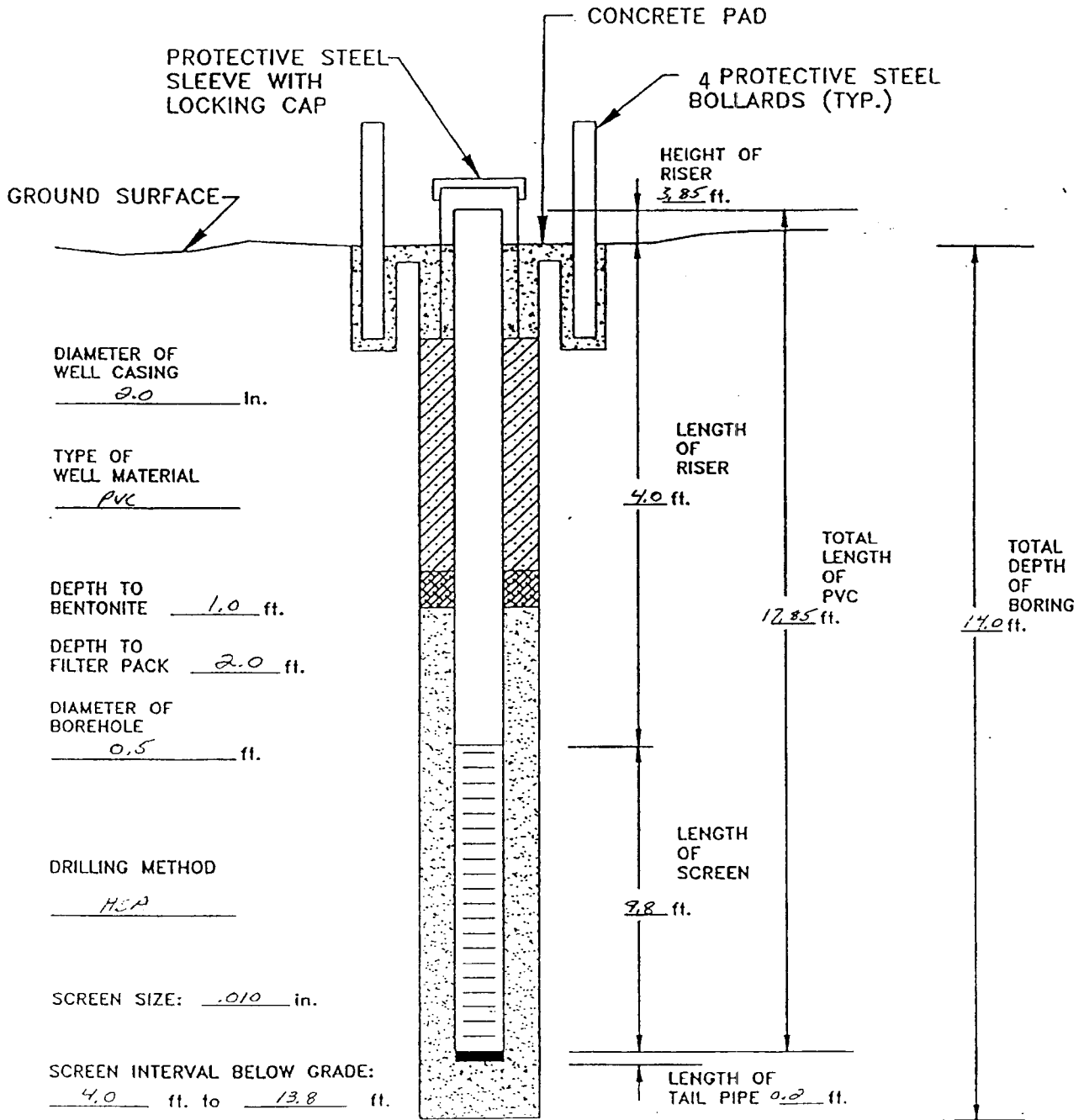

BAKER ENVIRONMENTAL REPRESENTATIVE: KENNETH A. TUA

ABOVE GRADE TYPE II MONITORING WELL

PROJECT No.: 19013-S1-SRN
PROJECT NAME: FUEL FARM
WELL No.: MW-4
DRILLING CO.: ATEC

DATE STARTED: 12-13-91
DATE COMPLETED: 12-13-91
DATE DEVELOPED: 12-14-91
DEVELOPMENT METHOD: PUMP

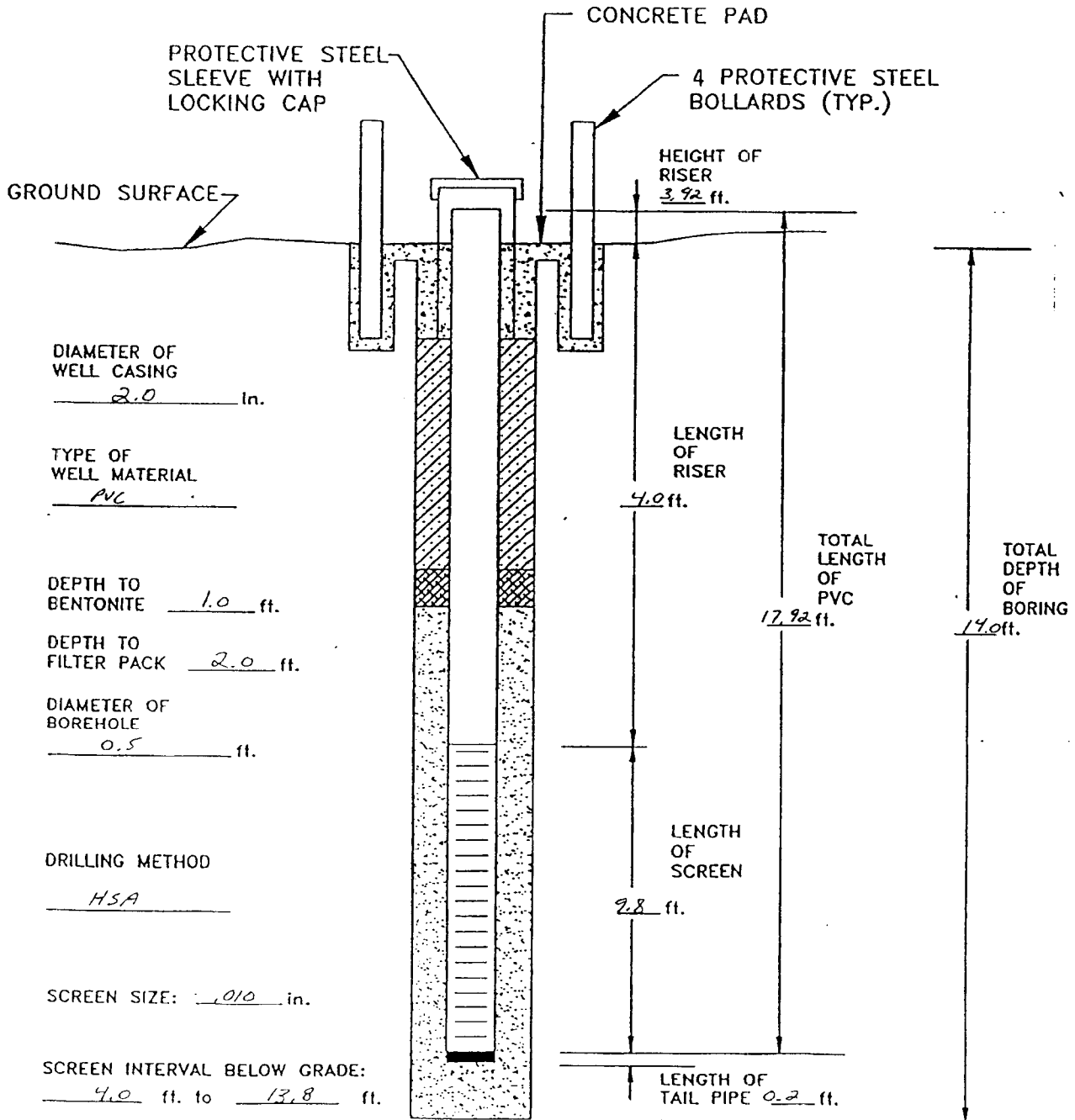

BAKER ENVIRONMENTAL REPRESENTATIVE: KENNETH A. TUA

Baker

Baker Environmental, Inc.

ABOVE GRADE TYPE II MONITORING WELL

PROJECT No.: 19013-S1-SRN
PROJECT NAME: CSFF
WELL No.: MW-5
DRILLING CO.: ATEL

DATE STARTED: 12/12/91
DATE COMPLETED: 12/12/91
DATE DEVELOPED: 12/13/91
DEVELOPMENT METHOD: SURGE & PUMP

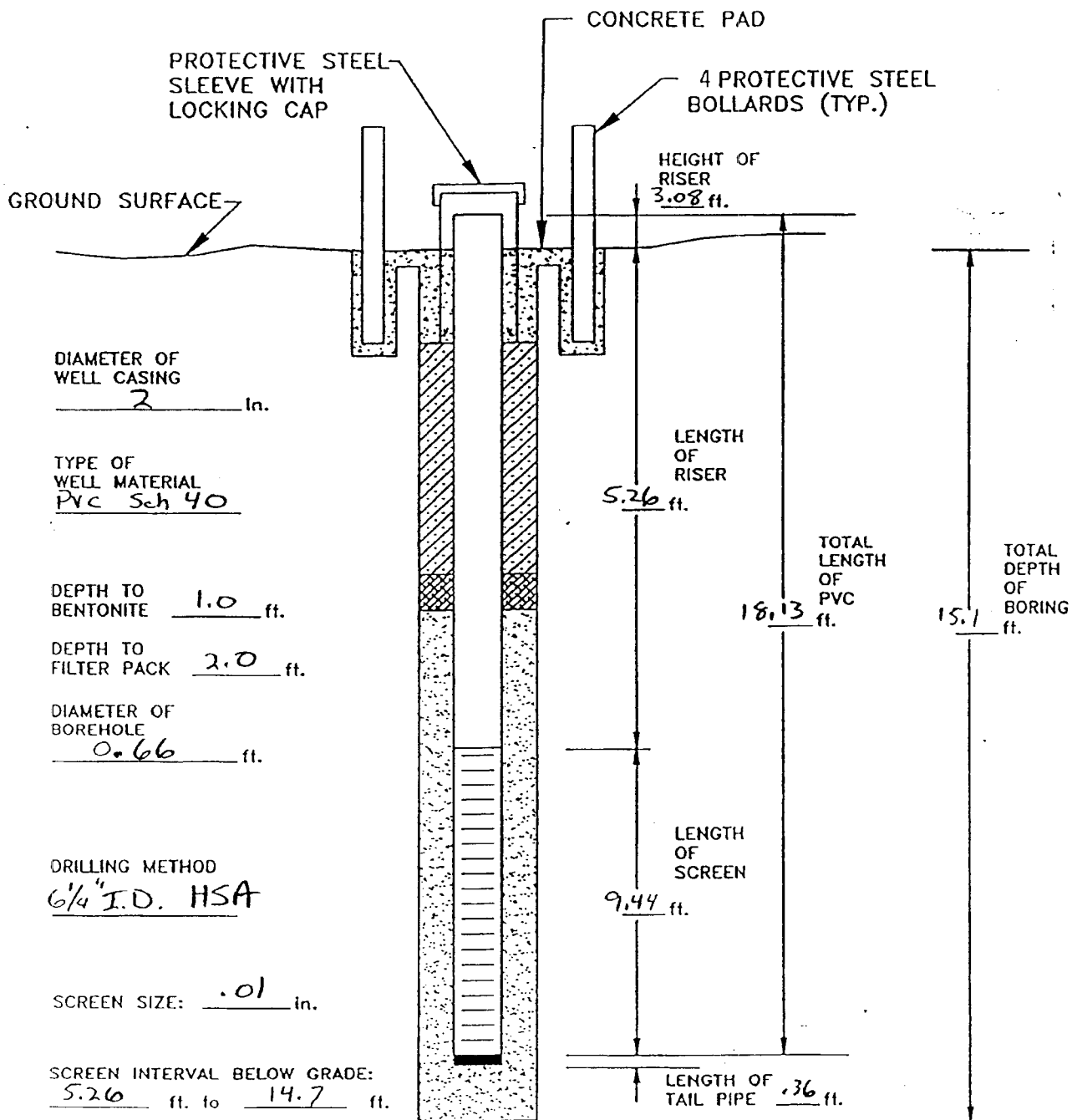

BAKER ENVIRONMENTAL REPRESENTATIVE: R. SEVCIK

ABOVE GRADE TYPE II MONITORING WELL

PROJECT No.: 1903-51-SRN
 PROJECT NAME: FUEL FARM
 WELL No.: 17W-7
 DRILLING CO.: ATEC

DATE STARTED: 12-13-91
 DATE COMPLETED: 12-13-91
 DATE DEVELOPED: 12-16-91
 DEVELOPMENT METHOD: PUMP

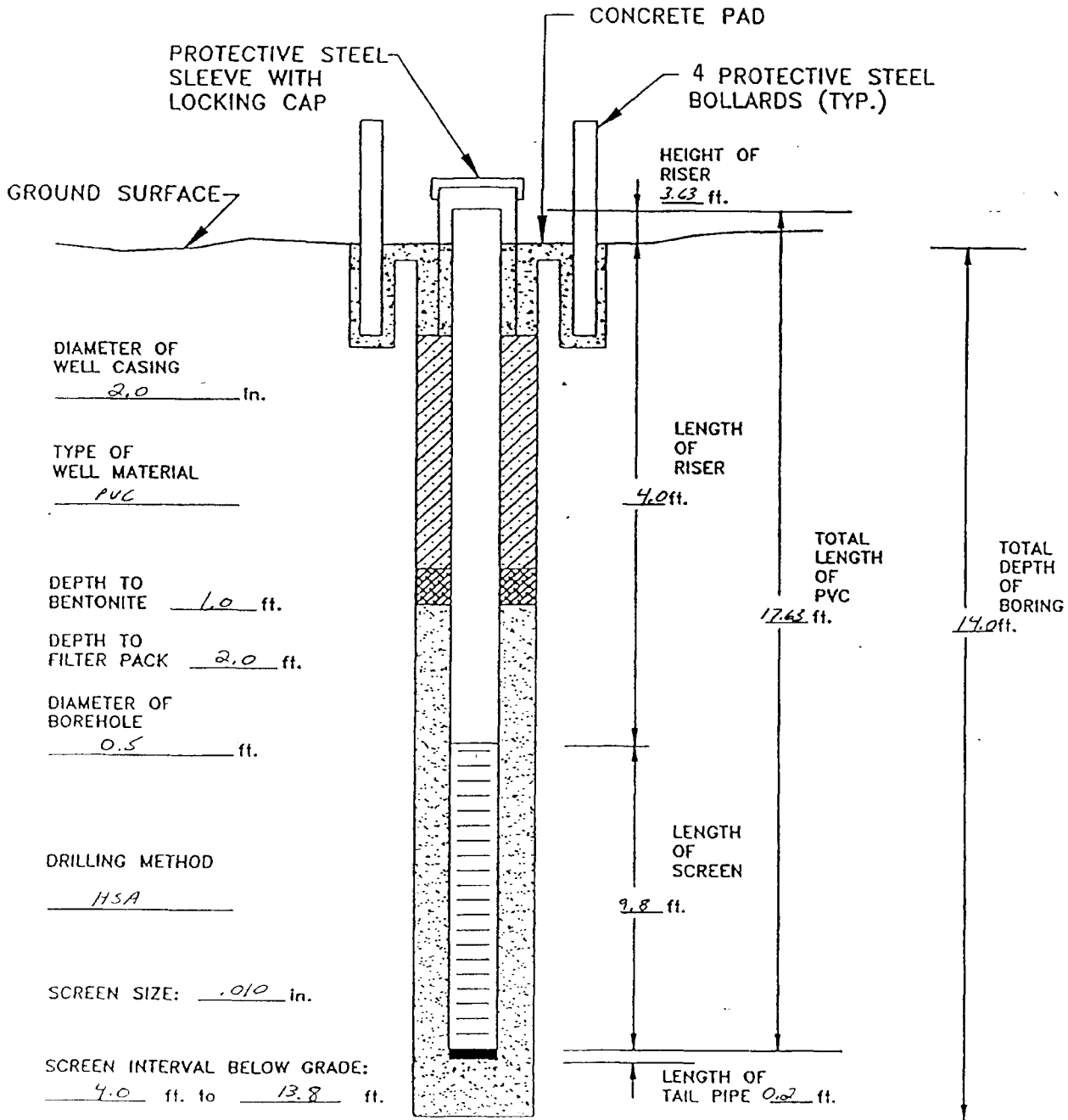

BAKER ENVIRONMENTAL REPRESENTATIVE: KENNETH A. TUA

ABOVE GRADE TYPE II MONITORING WELL

PROJECT No.: 19013-50-SRN
 PROJECT NAME: Campbell St. FUEL FARM
 WELL No.: MW-8
 DRILLING CO.: NPTC

DATE STARTED: 11-19-92
 DATE COMPLETED: 11-19-92
 DATE DEVELOPED: 12-2-92
 DEVELOPMENT METHOD: PUMP

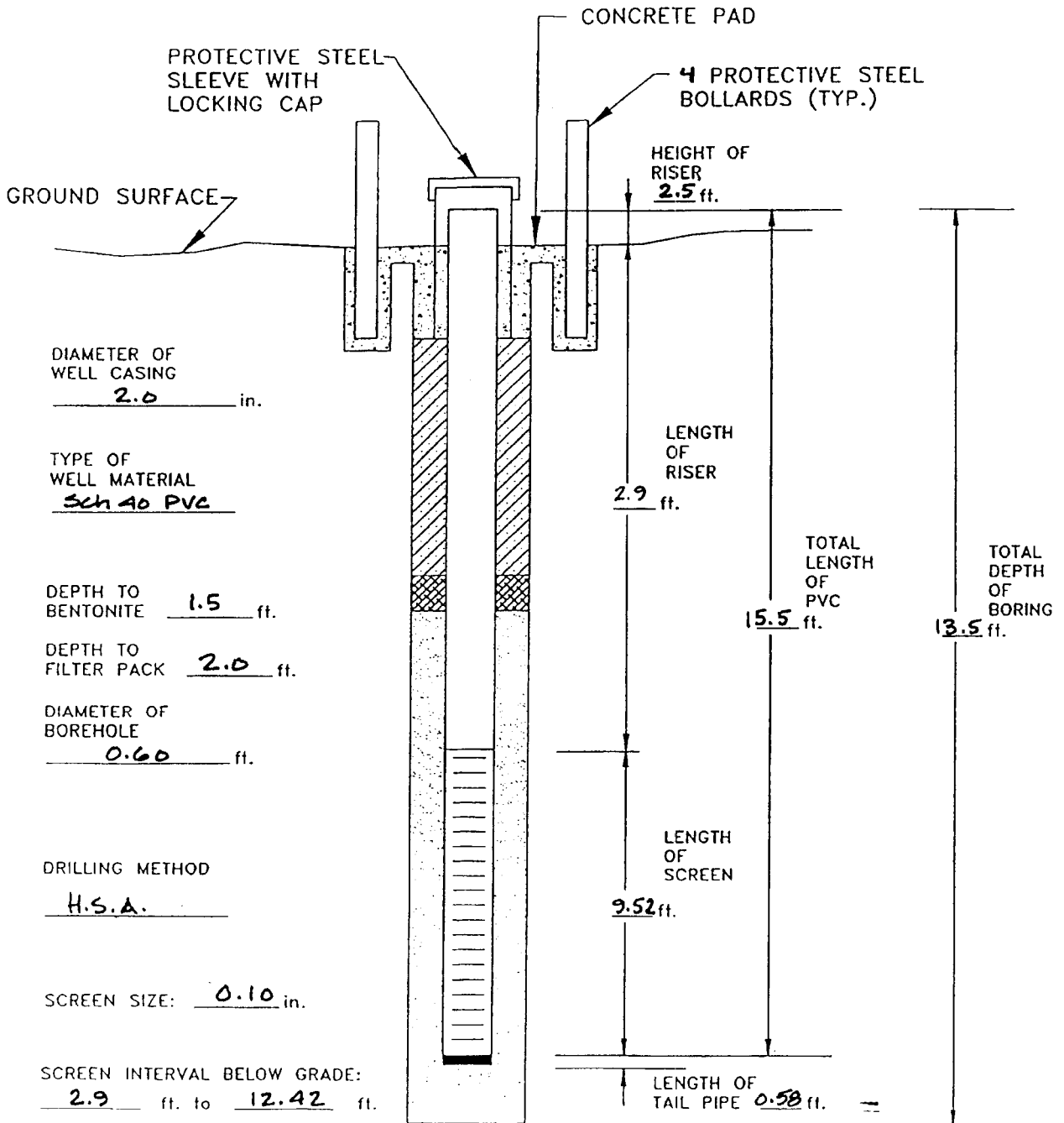

BAKER ENVIRONMENTAL REPRESENTATIVE: James S. Culp

ABOVE GRADE TYPE II MONITORING WELL

PROJECT No.: 19013-50-SRN
 PROJECT NAME: Campbell St. FUEL FARM
 WELL No.: MW-9
 DRILLING CO.: NPTC

DATE STARTED: 11-19-92
 DATE COMPLETED: 11-19-92
 DATE DEVELOPED: 12-2-92
 DEVELOPMENT METHOD: PUMP

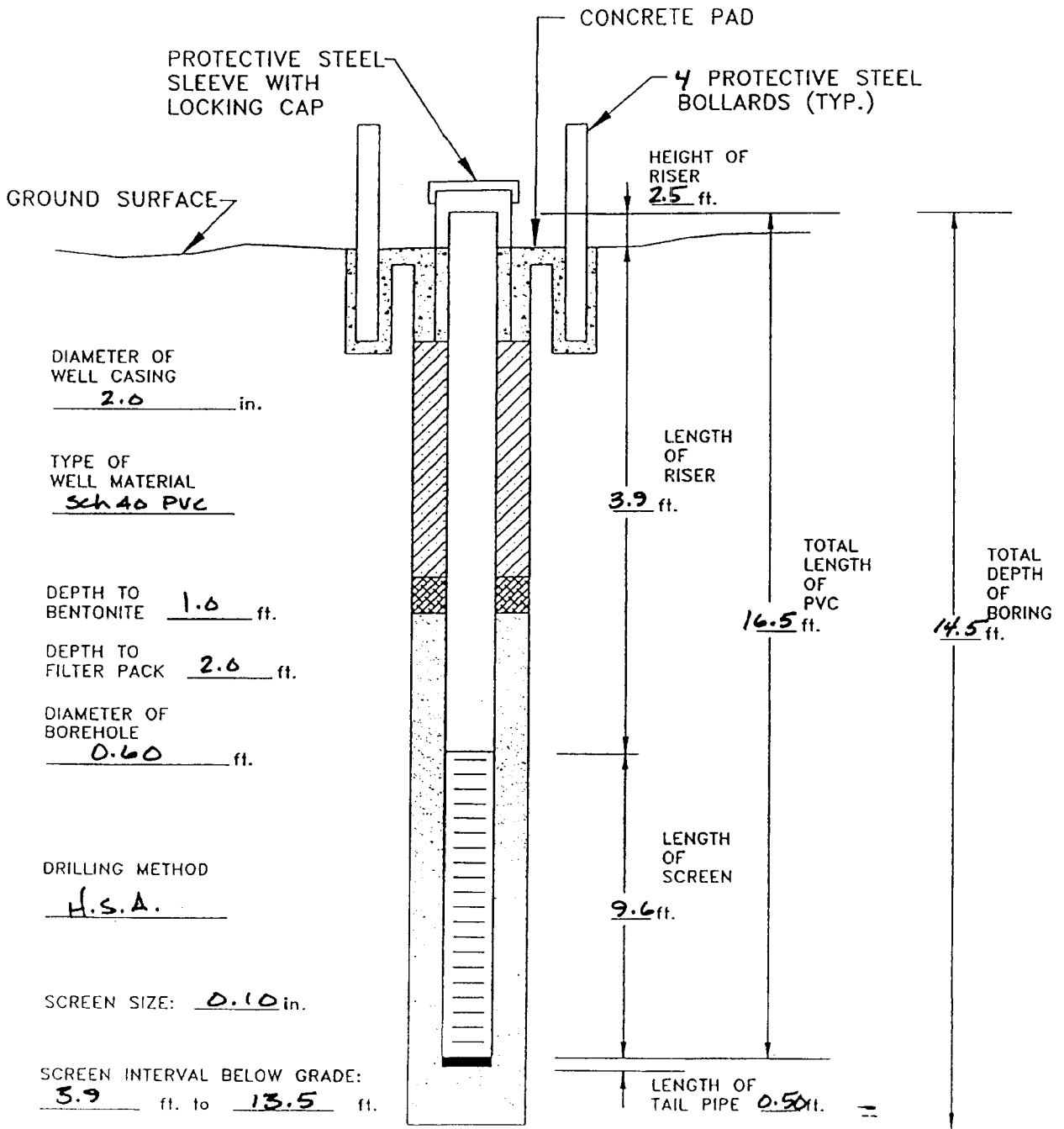

BAKER ENVIRONMENTAL REPRESENTATIVE: James S. Culp

ABOVE GRADE TYPE II MONITORING WELL

PROJECT No.: 19013-50-SRN
 PROJECT NAME: Campbell St. FUEL FARM
 WELL No.: MW-10
 DRILLING CO.: NPTC

DATE STARTED: 11-19-92
 DATE COMPLETED: 11-19-92
 DATE DEVELOPED: 12-2-92
 DEVELOPMENT METHOD: Bailer

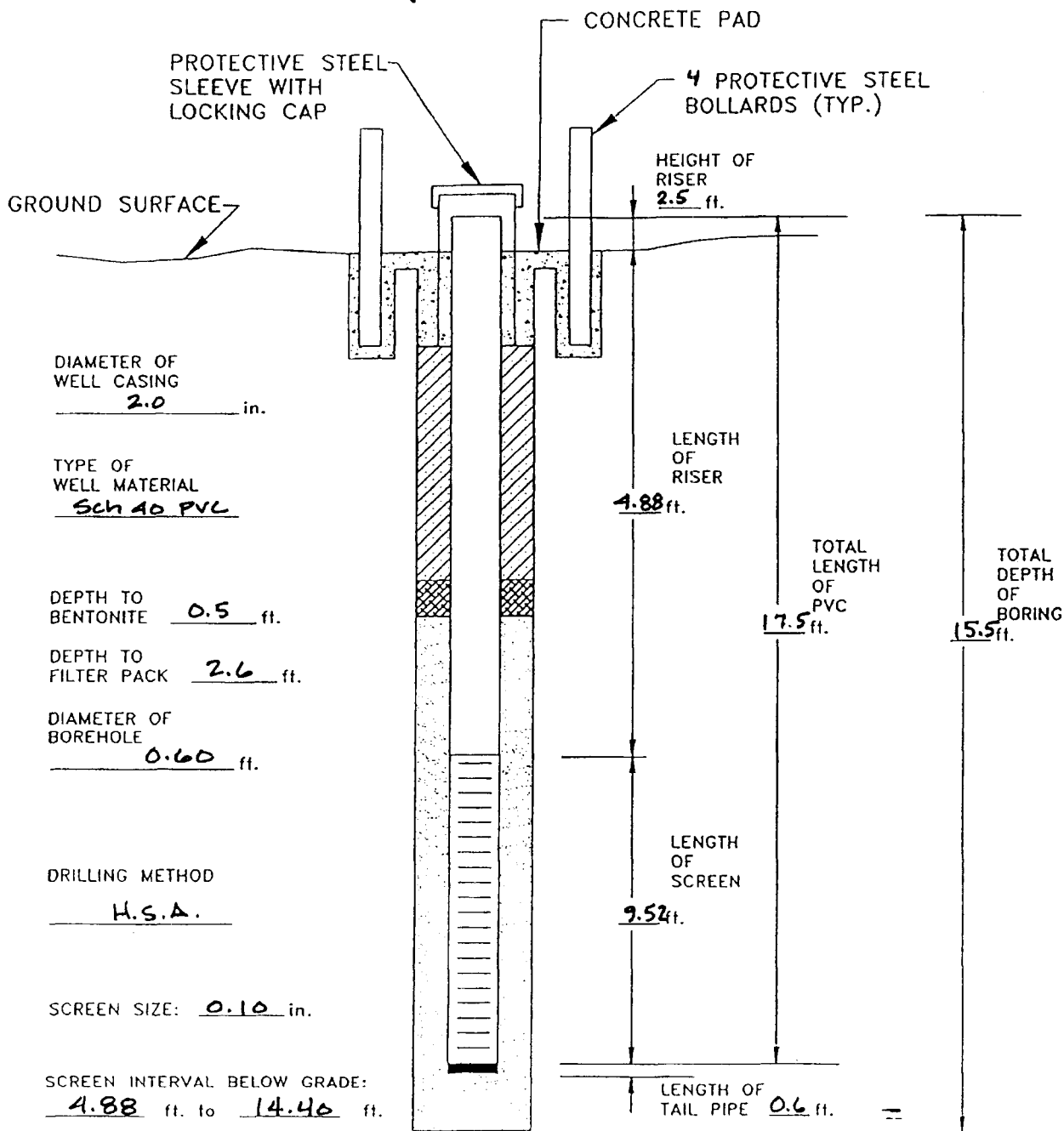

BAKER ENVIRONMENTAL REPRESENTATIVE: James S. Culp

ABOVE GRADE TYPE II MONITORING WELL

PROJECT No.: 19013-50-SRN
PROJECT NAME: Campbell St. Fuel Farm
WELL No.: MW-11
DRILLING CO.: NPTC

DATE STARTED: 11-18-92
DATE COMPLETED: 11-18-92
DATE DEVELOPED: 12-2-92
DEVELOPMENT METHOD: PUMP

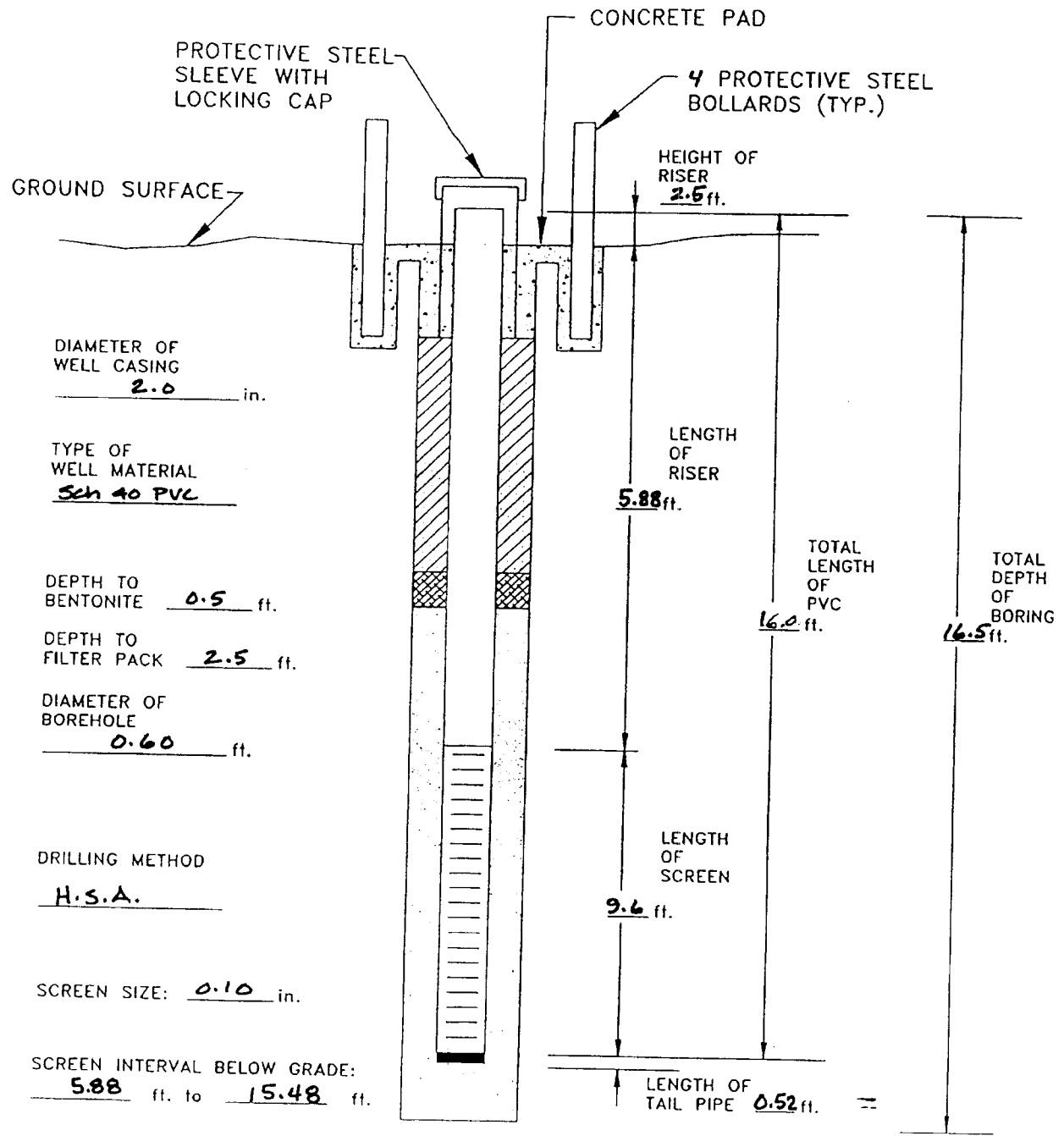

BAKER ENVIRONMENTAL REPRESENTATIVE: JAMES S. CULP

ABOVE GRADE TYPE II MONITORING WELL

PROJECT No.: 19013-50-SRN
 PROJECT NAME: Campbell St. FUEL FARM
 WELL No.: MW-12
 DRILLING CO.: NPTC

DATE STARTED: 11-19-92
 DATE COMPLETED: 11-19-92
 DATE DEVELOPED: 12-3-92
 DEVELOPMENT METHOD: PUMP

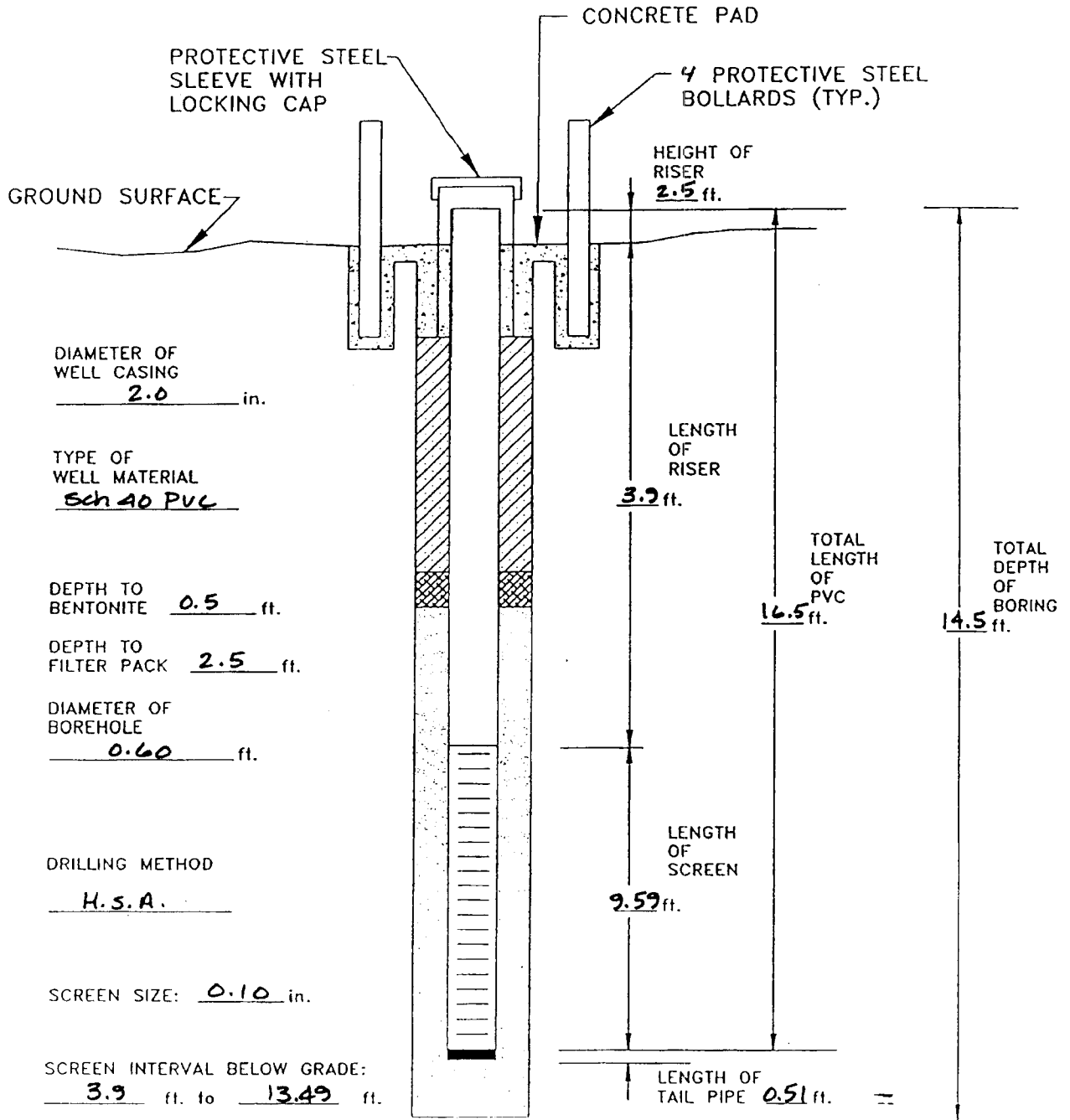

BAKER ENVIRONMENTAL REPRESENTATIVE: James S. Culp

Baker

Baker Environmental, Inc.

ABOVE GRADE TYPE II MONITORING WELL

PROJECT No.: 19013-50-SRN
PROJECT NAME: Campbell St. Fuel Farm
WELL No.: MW-13
DRILLING CO.: NPTC

DATE STARTED: 11-20-92
DATE COMPLETED: 11-20-92
DATE DEVELOPED: 12-3-92
DEVELOPMENT METHOD: PUMP

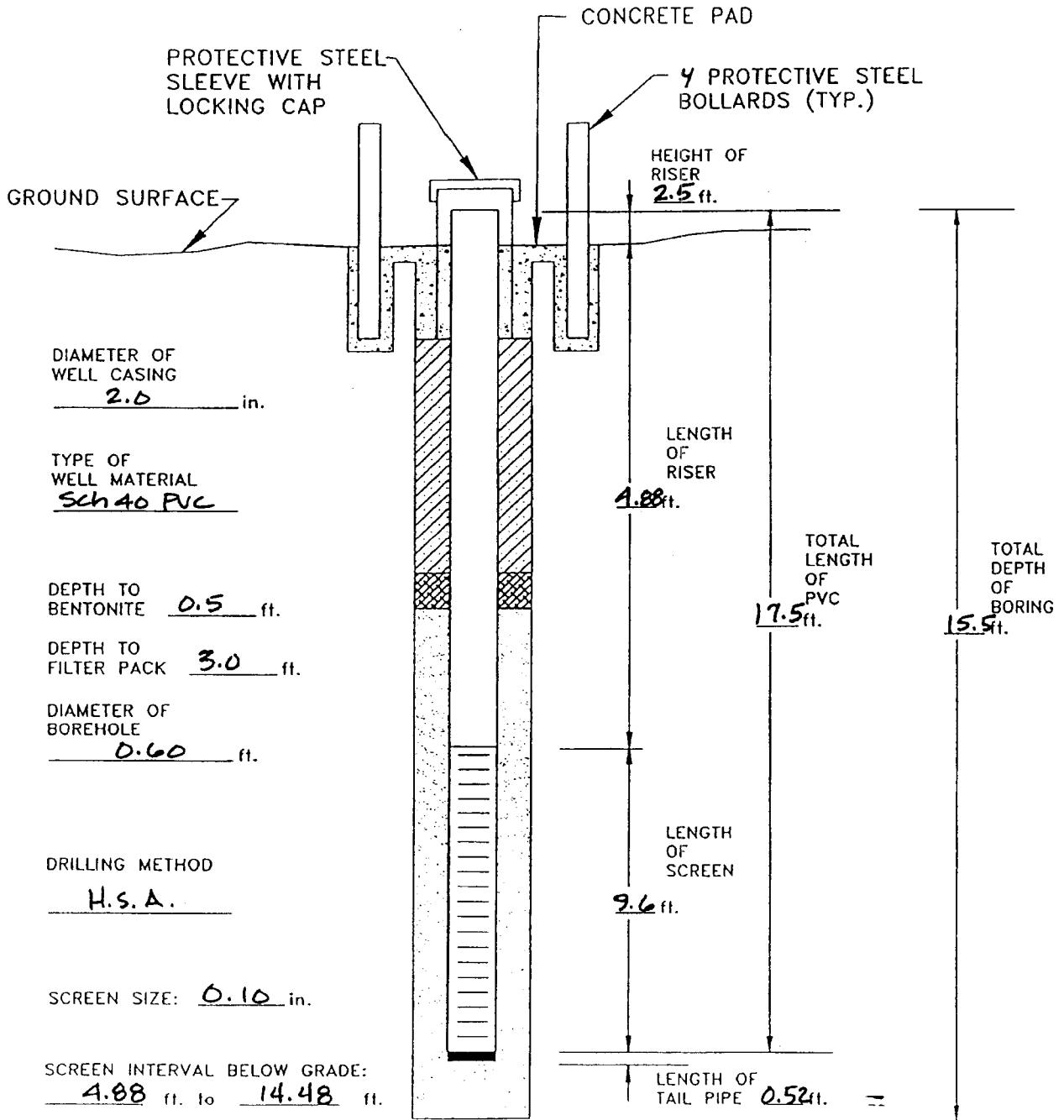

BAKER ENVIRONMENTAL REPRESENTATIVE:

James S. Culp

ABOVE GRADE TYPE II MONITORING WELL

PROJECT No.: 19013-50-SRN
 PROJECT NAME: Campbell St. FUEL FARM
 WELL No.: MW-14
 DRILLING CO.: NPTC

DATE STARTED: 11-20-92
 DATE COMPLETED: 11-20-92
 DATE DEVELOPED: 12-3-92
 DEVELOPMENT METHOD: PUMP

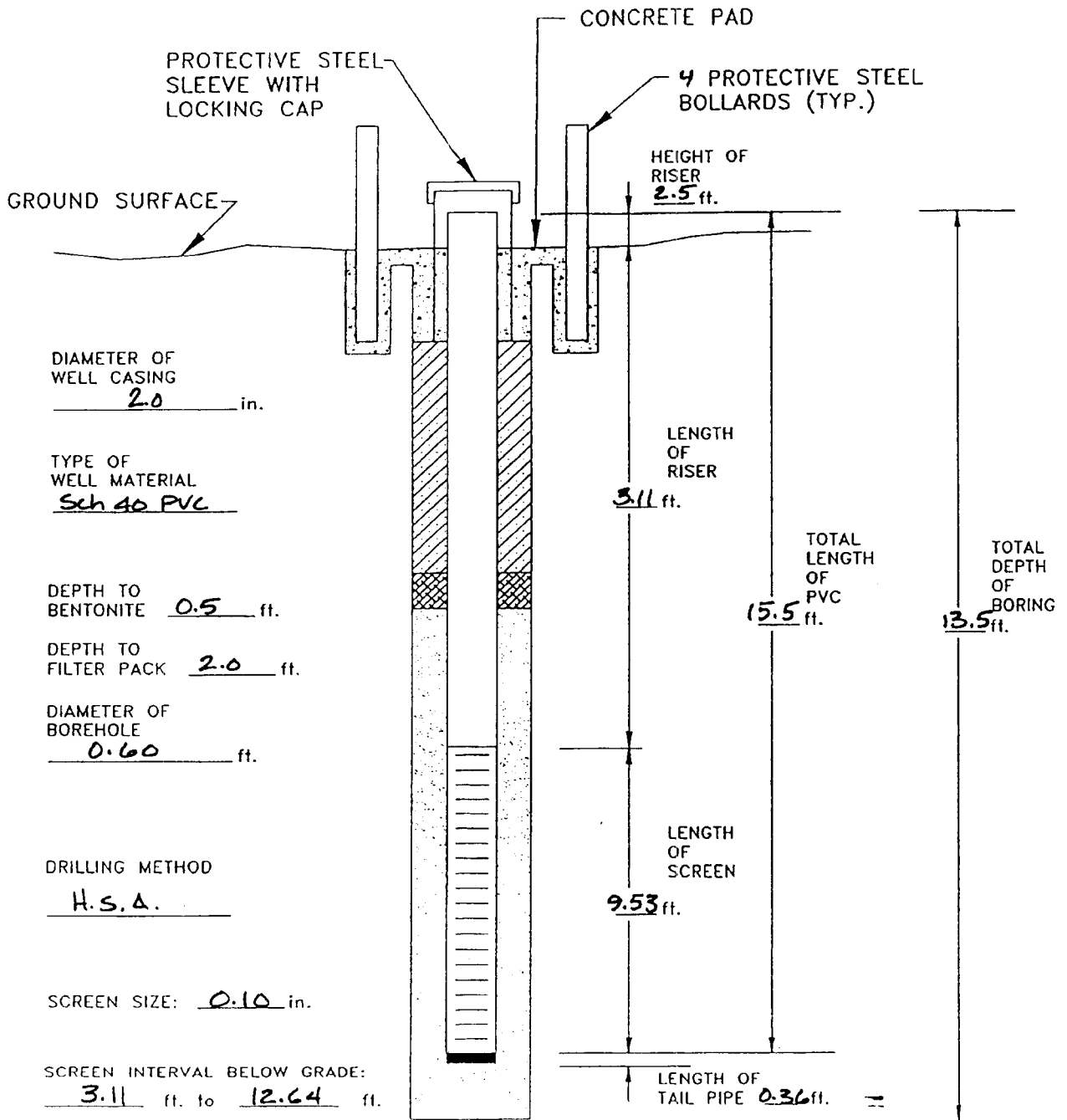

BAKER ENVIRONMENTAL REPRESENTATIVE: James S. Culp

Baker

Baker Environmental, Inc.

ABOVE GRADE TYPE II MONITORING WELL

PROJECT No.: 19013-50-SRW
PROJECT NAME: Campbell St. FUEL FARM
WELL No.: MW-15
DRILLING CO.: NPTC

DATE STARTED: 11-21-92
DATE COMPLETED: 11-21-92
DATE DEVELOPED: 12-3-92
DEVELOPMENT METHOD: PUMP

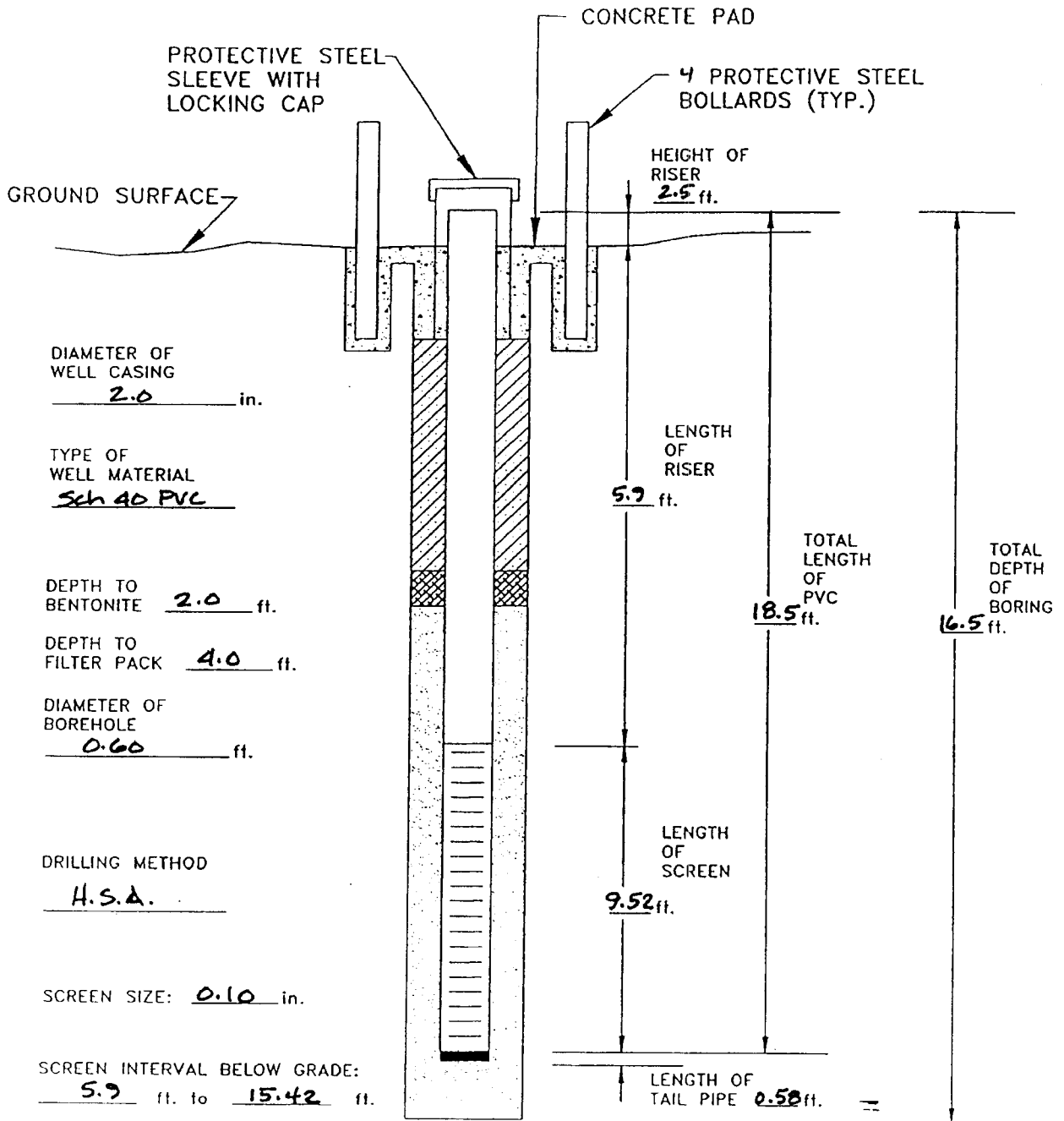

BAKER ENVIRONMENTAL REPRESENTATIVE:

James S. Culp

ABOVE GRADE TYPE II MONITORING WELL

PROJECT No.: 19013-50-SRN
 PROJECT NAME: Campbell St. FUEL FARM
 WELL No.: MW-16
 DRILLING CO.: NPTC

DATE STARTED: 11-20-92
 DATE COMPLETED: 11-20-92
 DATE DEVELOPED: 12-3-92
 DEVELOPMENT METHOD: PUMP

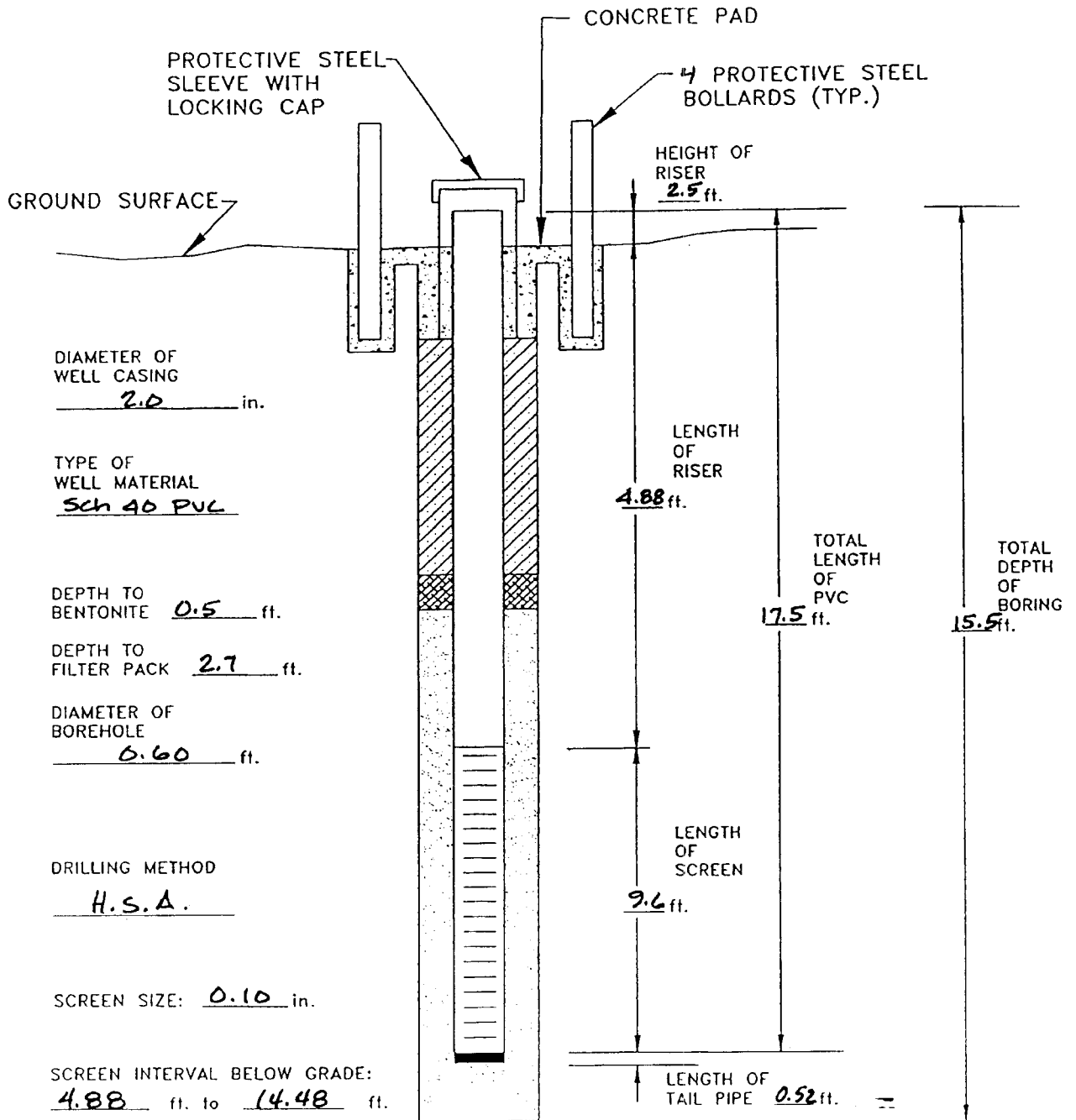

BAKER ENVIRONMENTAL REPRESENTATIVE: _____

ABOVE GRADE TYPE II MONITORING WELL

PROJECT No.: 19013-50-SRW
PROJECT NAME: Campbell St. Fuel Farm
WELL No.: MW-17
DRILLING CO.: NPTC

DATE STARTED: 11-20-92
DATE COMPLETED: 11-20-92
DATE DEVELOPED: 12-2-92
DEVELOPMENT METHOD: PUMP

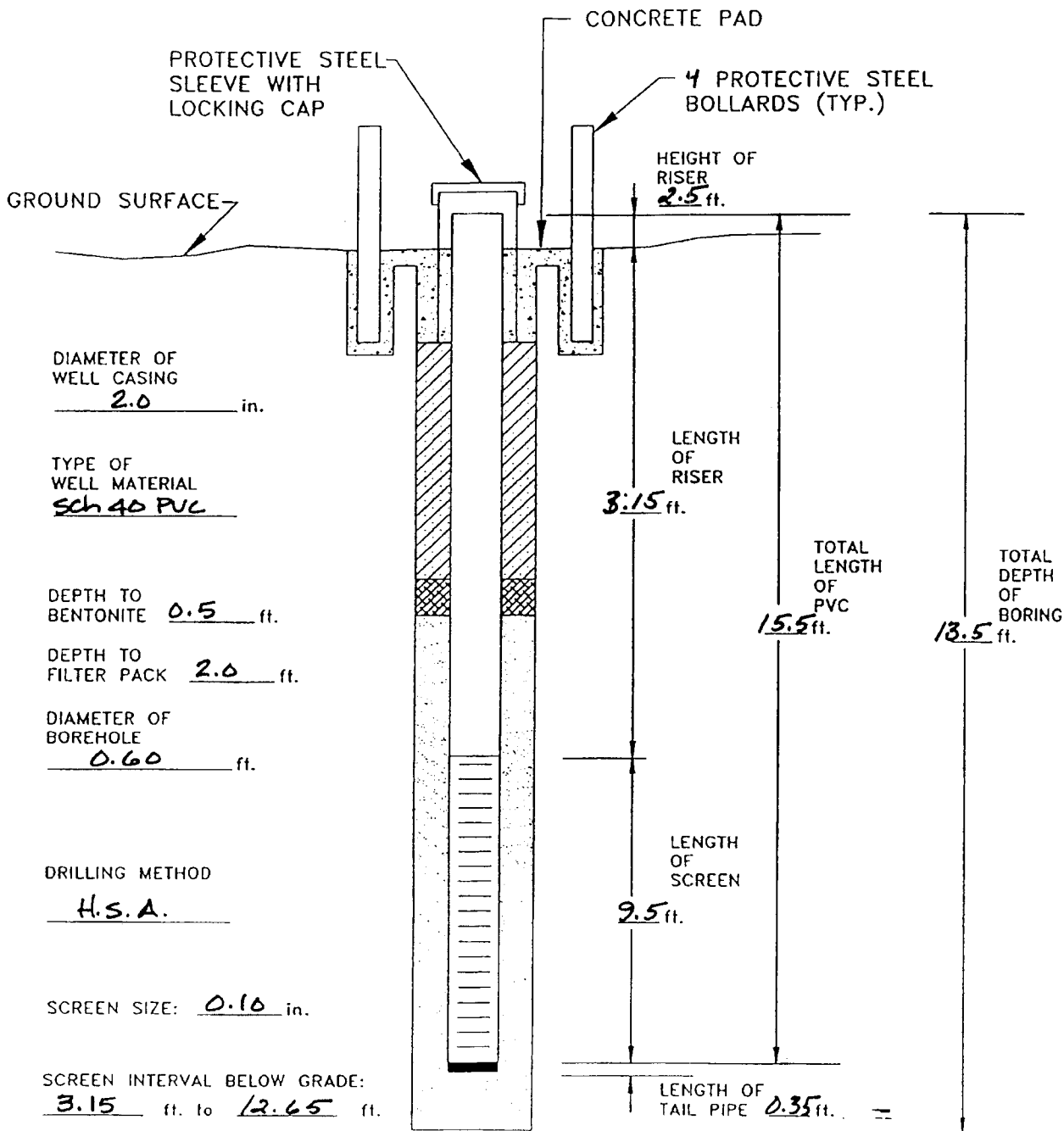

BAKER ENVIRONMENTAL REPRESENTATIVE: JAMES S. CULP

Baker

BELOW GRADE TYPE II MONITORING WELL

PROJECT No.: 19013-50-SRN
PROJECT NAME: Campbell St. Fuel Farm
WELL No.: MW-18
DRILLING CO.: NPTC

DATE STARTED: 11-22-92
DATE COMPLETED: 11-22-92
DATE DEVELOPED: 12-1-92
DEVELOPMENT METHOD: PUMP

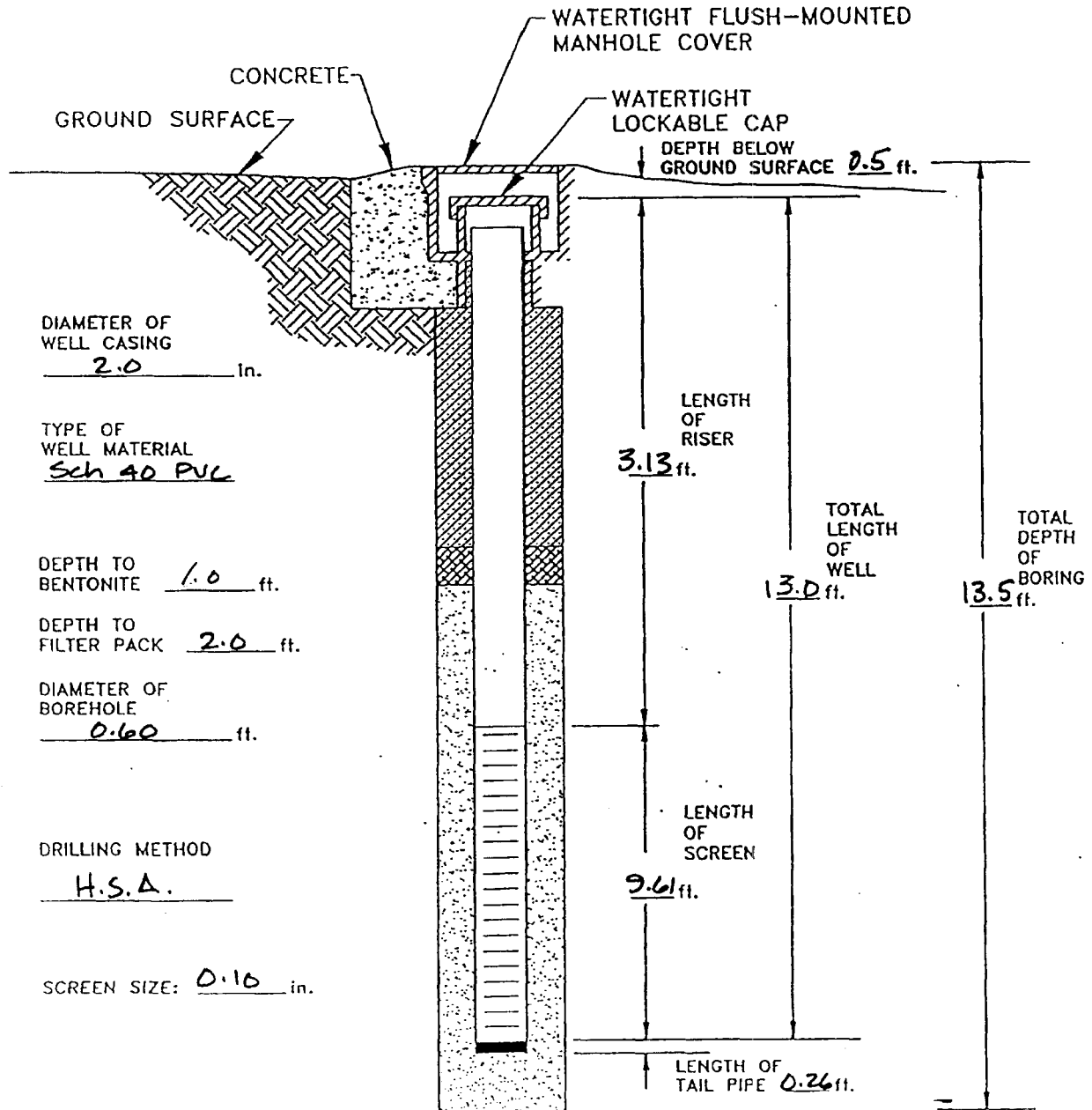

BAKER ENVIRONMENTAL REPRESENTATIVE: James S. Culp

BELOW GRADE TYPE II MONITORING WELL

PROJECT No.: 19013
PROJECT NAME: CAMPBELL STREET FUEL FARM
WELL No.: MW-19
DRILLING CO.: NPTC

DATE STARTED: 11-23-92
DATE COMPLETED: 11-23-92
DATE DEVELOPED: 12-2-92
DEVELOPMENT METHOD: PUMP

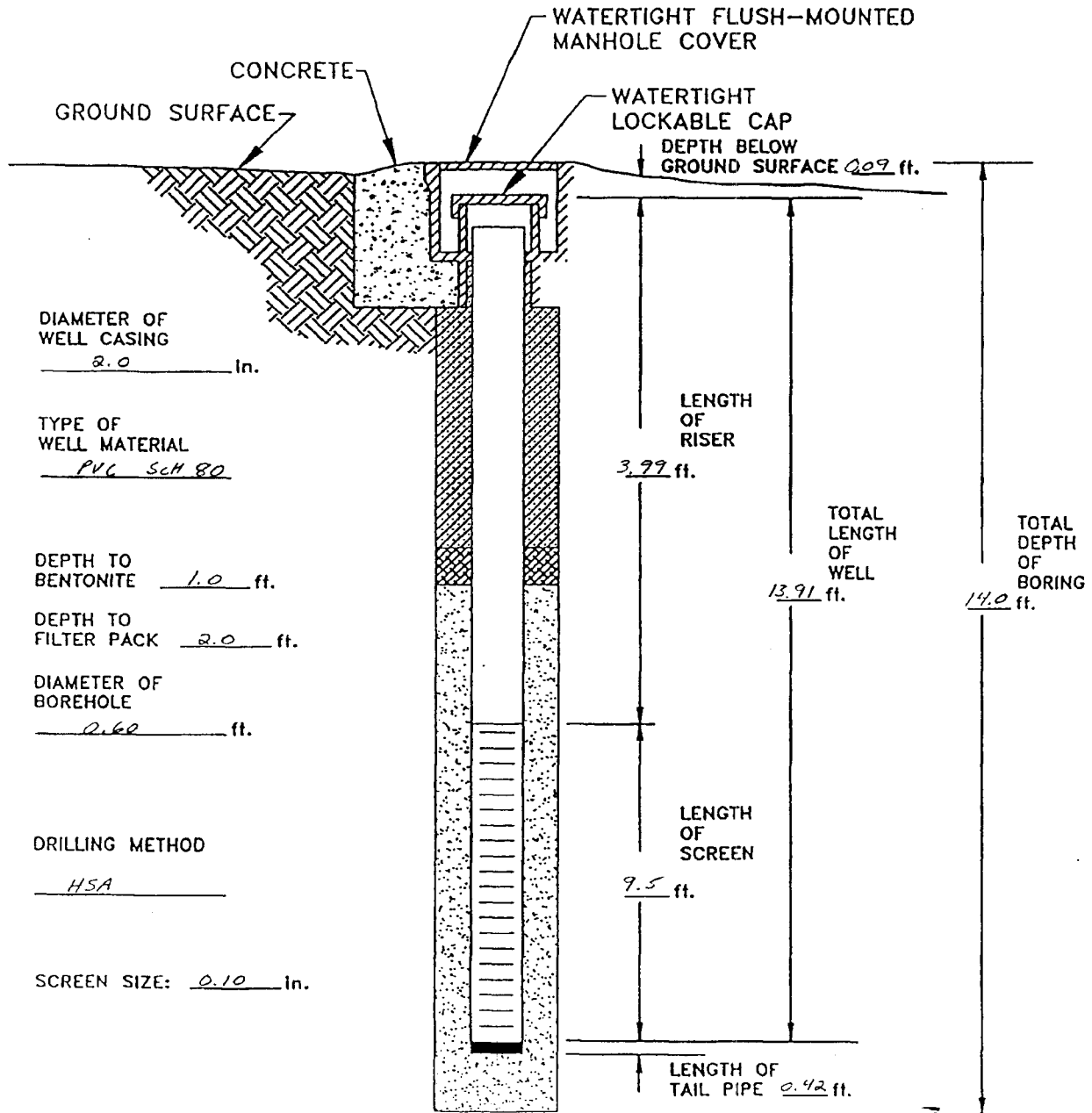

BELOW GRADE TYPE II MONITORING WELL

PROJECT No.: 19013-50-SRN
PROJECT NAME: Campbell St. Fuel Farm
WELL No.: MW-20
DRILLING CO.: NPTC

DATE STARTED: 11-23-92
DATE COMPLETED: 11-23-92
DATE DEVELOPED: 12-1-92
DEVELOPMENT METHOD: Baker

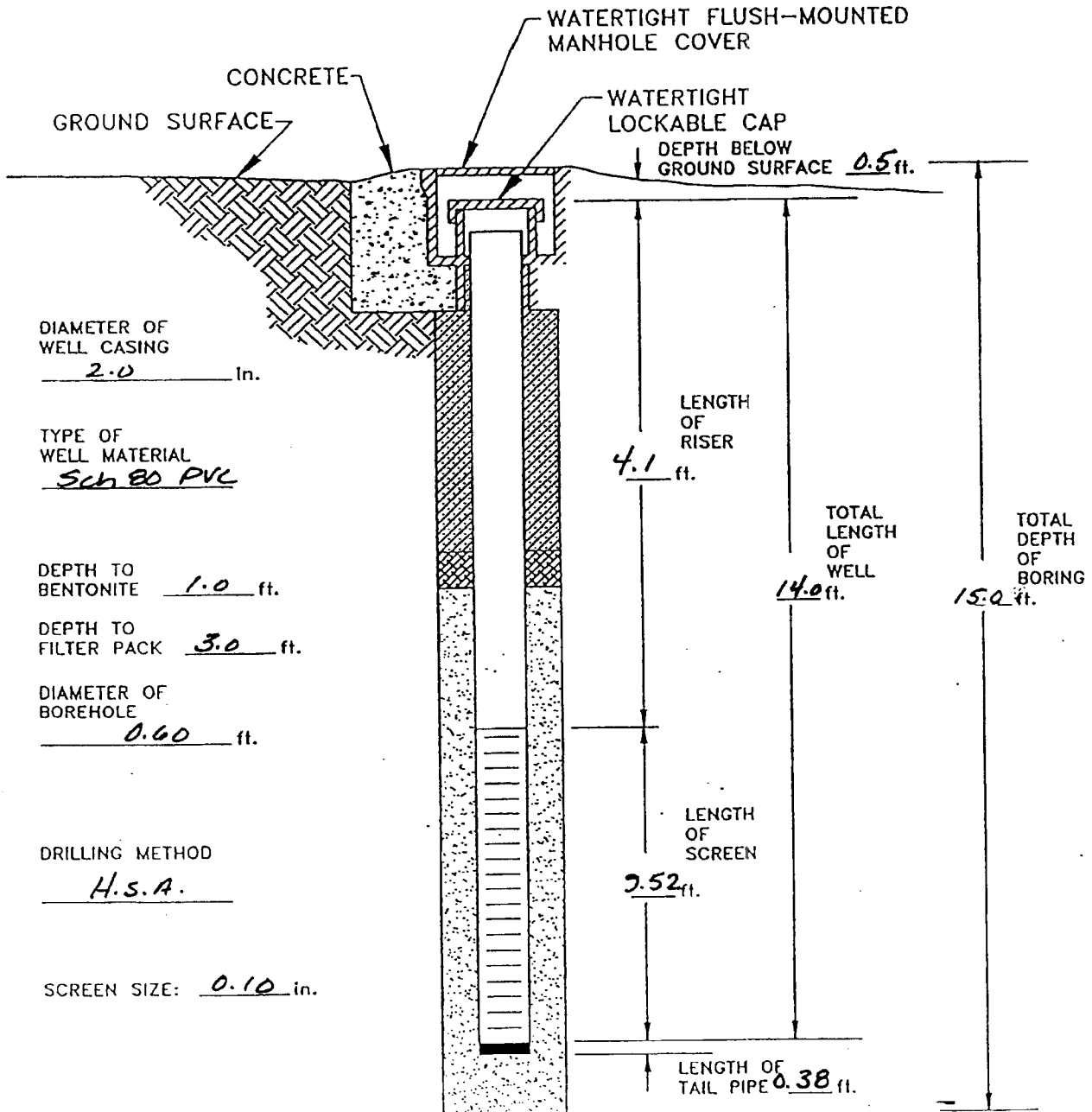

DRILLING METHOD
H.S.A.

SCREEN SIZE: 0.10 in.

BAKER ENVIRONMENTAL REPRESENTATIVE:

James S. Culp

Baker

Baker Environmental, Inc.

ABOVE GRADE TYPE II MONITORING WELL

PROJECT No.: 19013-50-SRN
PROJECT NAME: Campbell St. FUEL FARM
WELL No.: MW-21
DRILLING CO.: NPTC

DATE STARTED: 11-21-92
DATE COMPLETED: 11-21-92
DATE DEVELOPED: 12-2-92
DEVELOPMENT METHOD: PUMP

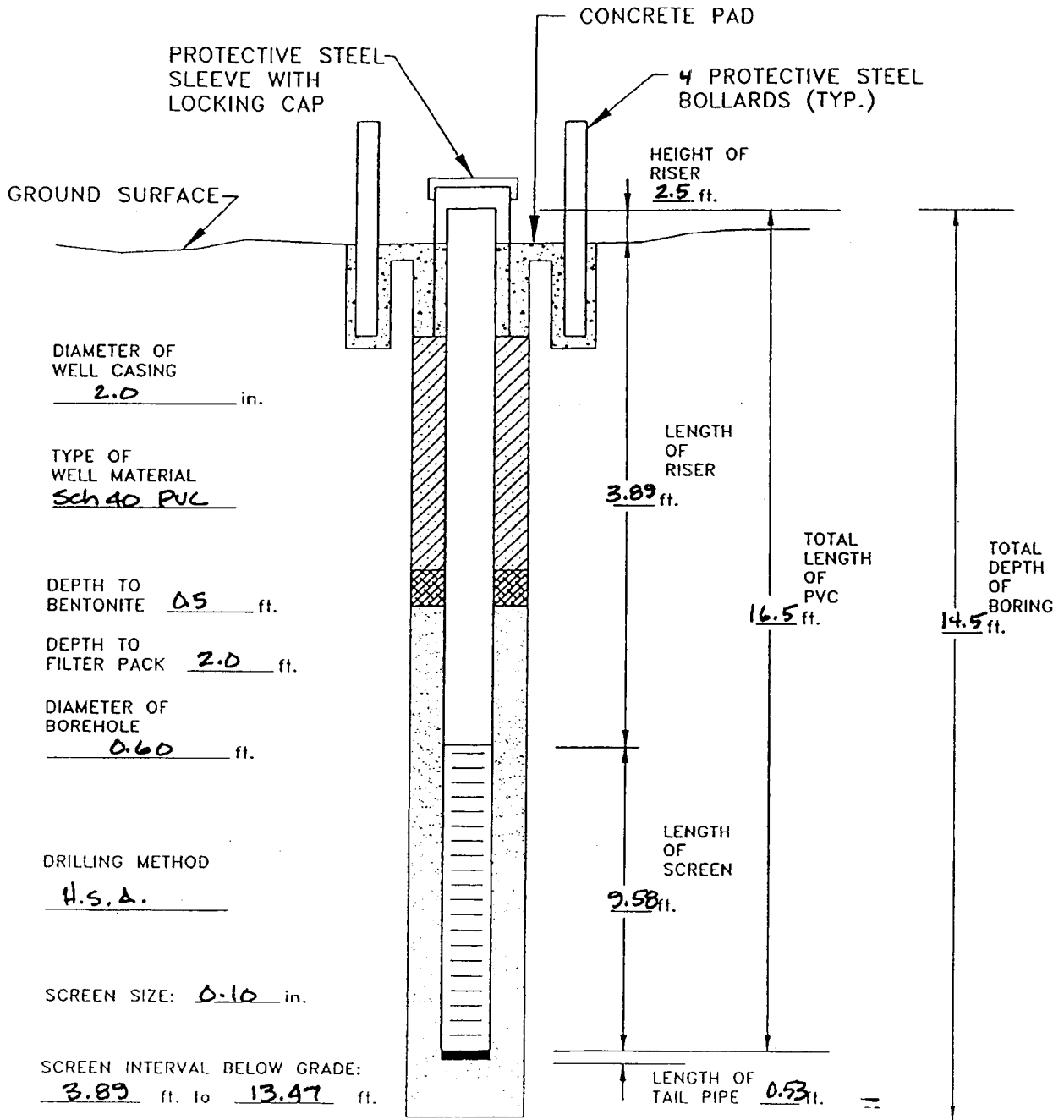

BAKER ENVIRONMENTAL REPRESENTATIVE: James S. Culp

Baker

Baker Environmental, Inc.

ABOVE GRADE TYPE II MONITORING WELL

PROJECT No.: 19013-50-SRN
 PROJECT NAME: Campbell St. FUEL FARM
 WELL No.: MW-24
 DRILLING CO.: NPTC

DATE STARTED: 11-22-92
 DATE COMPLETED: 11-22-92
 DATE DEVELOPED: 12-2-92
 DEVELOPMENT METHOD: Bailer

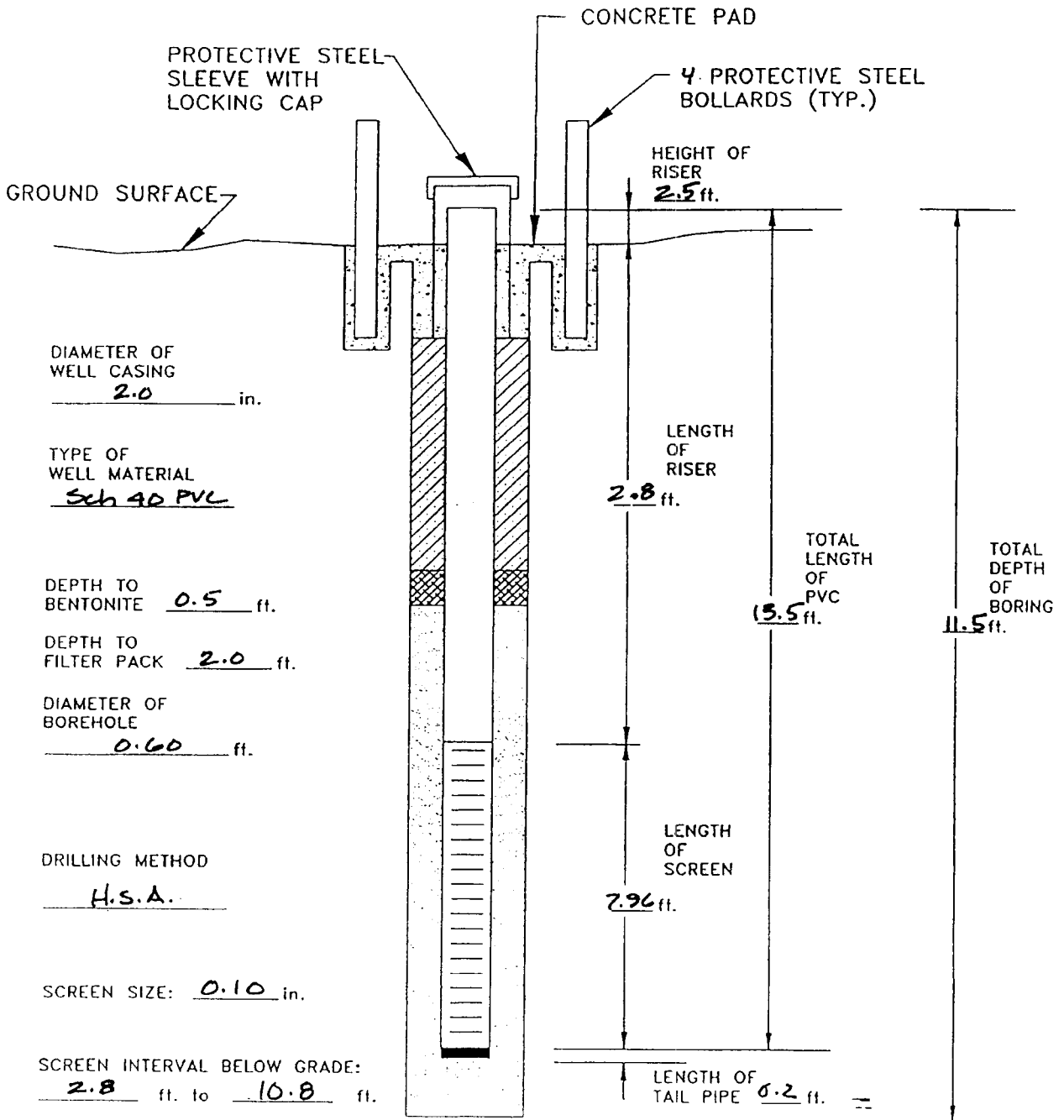

BAKER ENVIRONMENTAL REPRESENTATIVE:

James S. Culp

Baker

Baker Environmental, Inc.

ABOVE GRADE TYPE III MONITORING WELL

PROJECT No.: 19013-51-SRN
PROJECT NAME: FUEL FARM
WELL No.: DW-1
DRILLING CO.: ATEL

DATE STARTED: 12-17-91
DATE COMPLETED: 12-19-91
DATE DEVELOPED: 1-8-92
DEVELOPMENT METHOD: PUMP

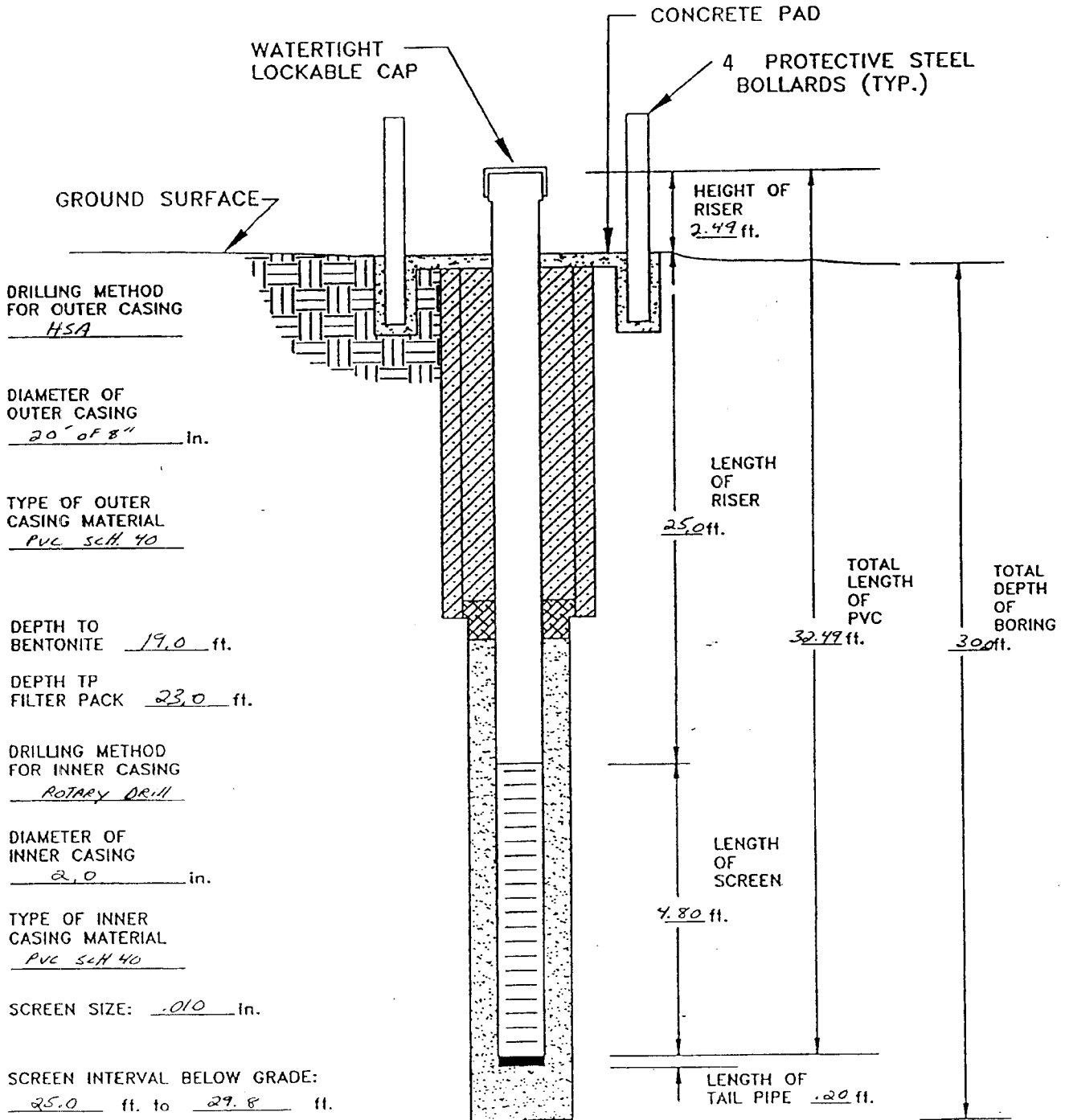

BAKER ENVIRONMENTAL REPRESENTATIVE: BOB SEVIC & KENNETH TUM

Baker

Baker Environmental, Inc.

ABOVE GRADE TYPE III MONITORING WELL

PROJECT No.: 19013-51-SRN
 PROJECT NAME: FUEL FARM
 WELL No.: DW-2
 DRILLING CO.: ATEL

DATE STARTED: 1-6-92
 DATE COMPLETED: 1-7-92
 DATE DEVELOPED: 1-8-92
 DEVELOPMENT METHOD: PUMP

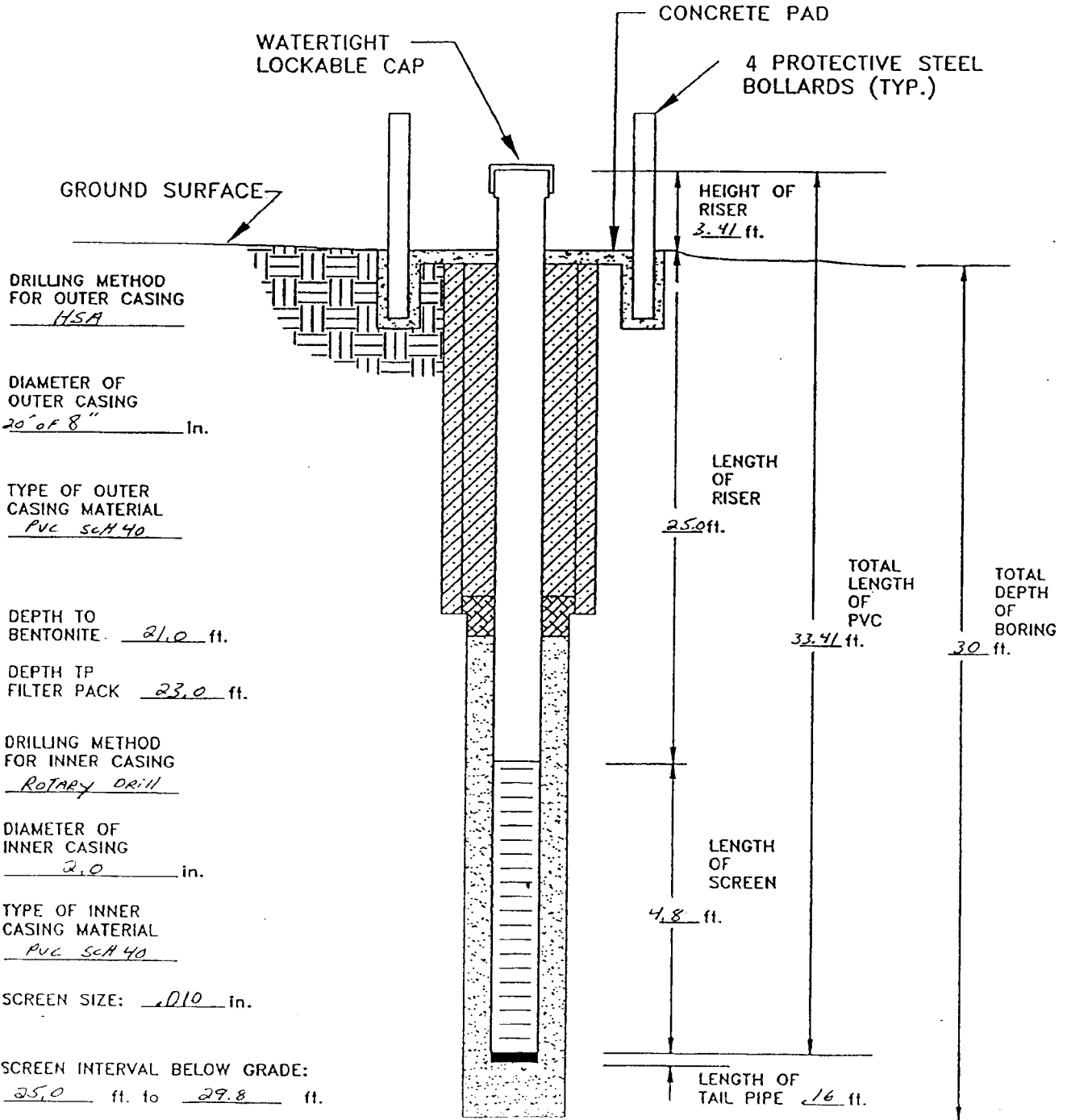

BAKER ENVIRONMENTAL REPRESENTATIVE: KENNETH A. TUA

ABOVE GRADE TYPE III MONITORING WELL

PROJECT No.: 19013

PROJECT NAME: CAMPBELL STREET FUEL FARM

WELL No.: DN-4

DRILLING CO.: NPTC

DATE STARTED: 11-20-92

DATE COMPLETED: 11-22-92

DATE DEVELOPED: 12-2-92

DEVELOPMENT METHOD: PUMP

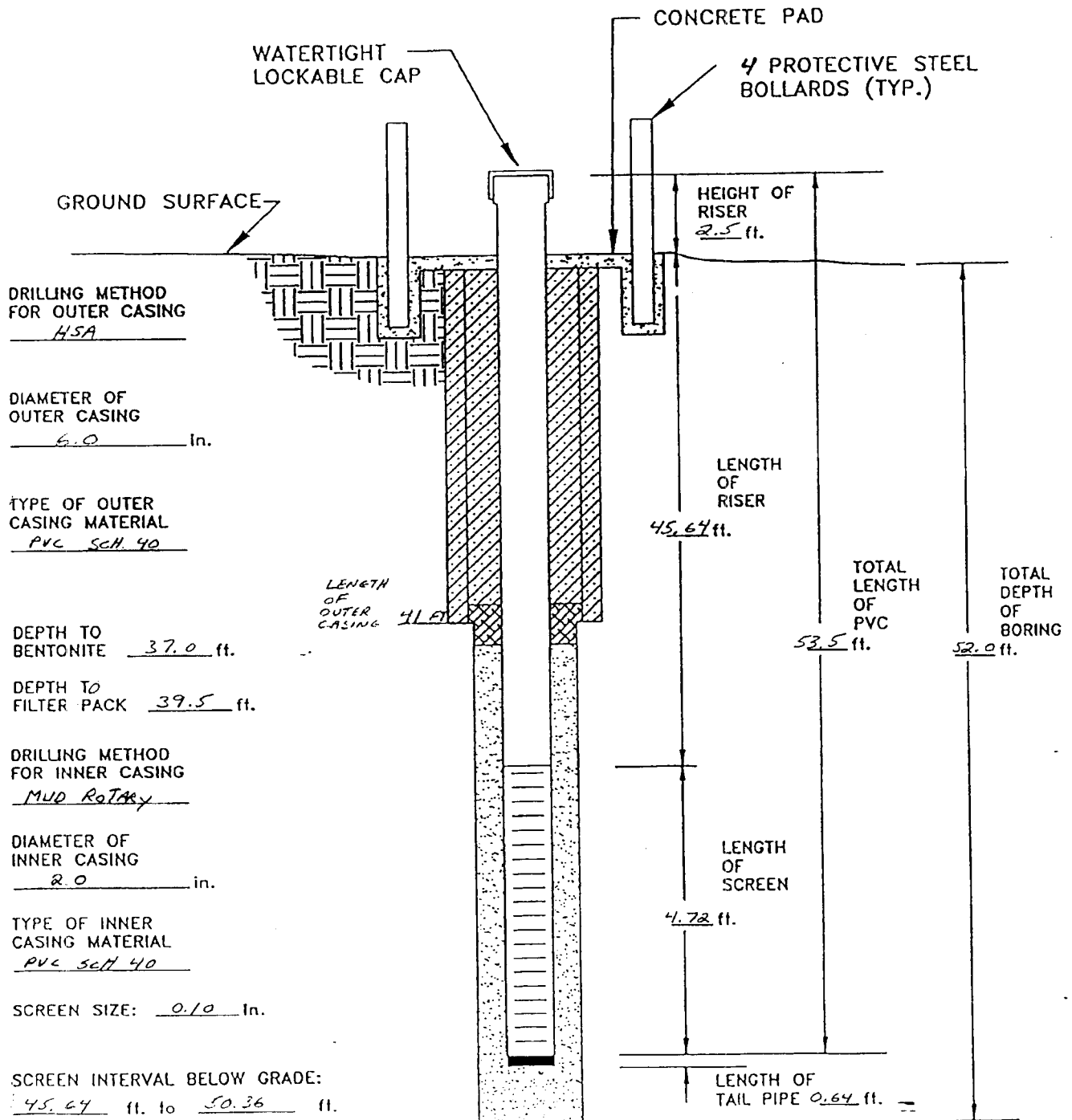

DRILLING METHOD FOR OUTER CASING
HSA

DIAMETER OF OUTER CASING
6.0 in.

TYPE OF OUTER CASING MATERIAL
PVC SCH 40

DEPTH TO BENTONITE 37.0 ft.

DEPTH TO FILTER PACK 39.5 ft.

DRILLING METHOD FOR INNER CASING
MUD ROTARY

DIAMETER OF INNER CASING
2.0 in.

TYPE OF INNER CASING MATERIAL
PVC SCH 40

SCREEN SIZE: 0.10 in.

SCREEN INTERVAL BELOW GRADE:
45.64 ft. to 50.36 ft.

BAKER ENVIRONMENTAL REPRESENTATIVE: KENNETH A. TUA

ABOVE GRADE TYPE III MONITORING WELL

PROJECT No.: 19013

DATE STARTED: 11-18-92

PROJECT NAME: CAMPBELL STREET FUEL FARM

DATE COMPLETED: 11-19-92

WELL No.: DW-5

DATE DEVELOPED: 12-2-92

DRILLING CO.: NPTC

DEVELOPMENT METHOD: PUMP

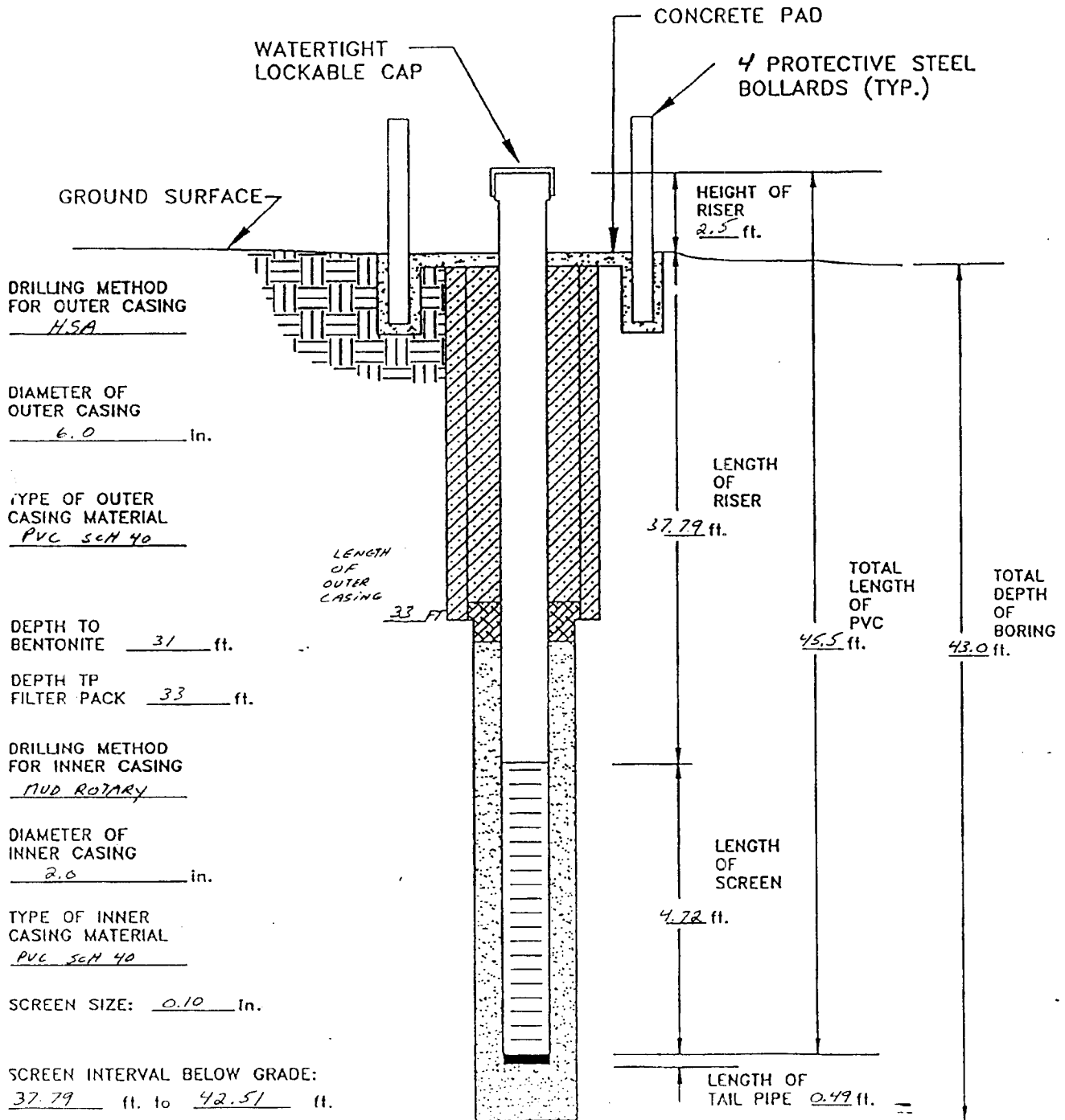

BAKER ENVIRONMENTAL REPRESENTATIVE: KENNETH A. TUA

Baker

Baker Environmental, Inc.

ABOVE GRADE TYPE III MONITORING WELL

PROJECT No.: 19013

DATE STARTED: 12-1-92

PROJECT NAME: CAMPBELL STREET FUEL FARM

DATE COMPLETED: 12-2-92

WELL No.: DW-6

DATE DEVELOPED: 12-3-92

DRILLING CO.: NPTC

DEVELOPMENT METHOD: PUMP

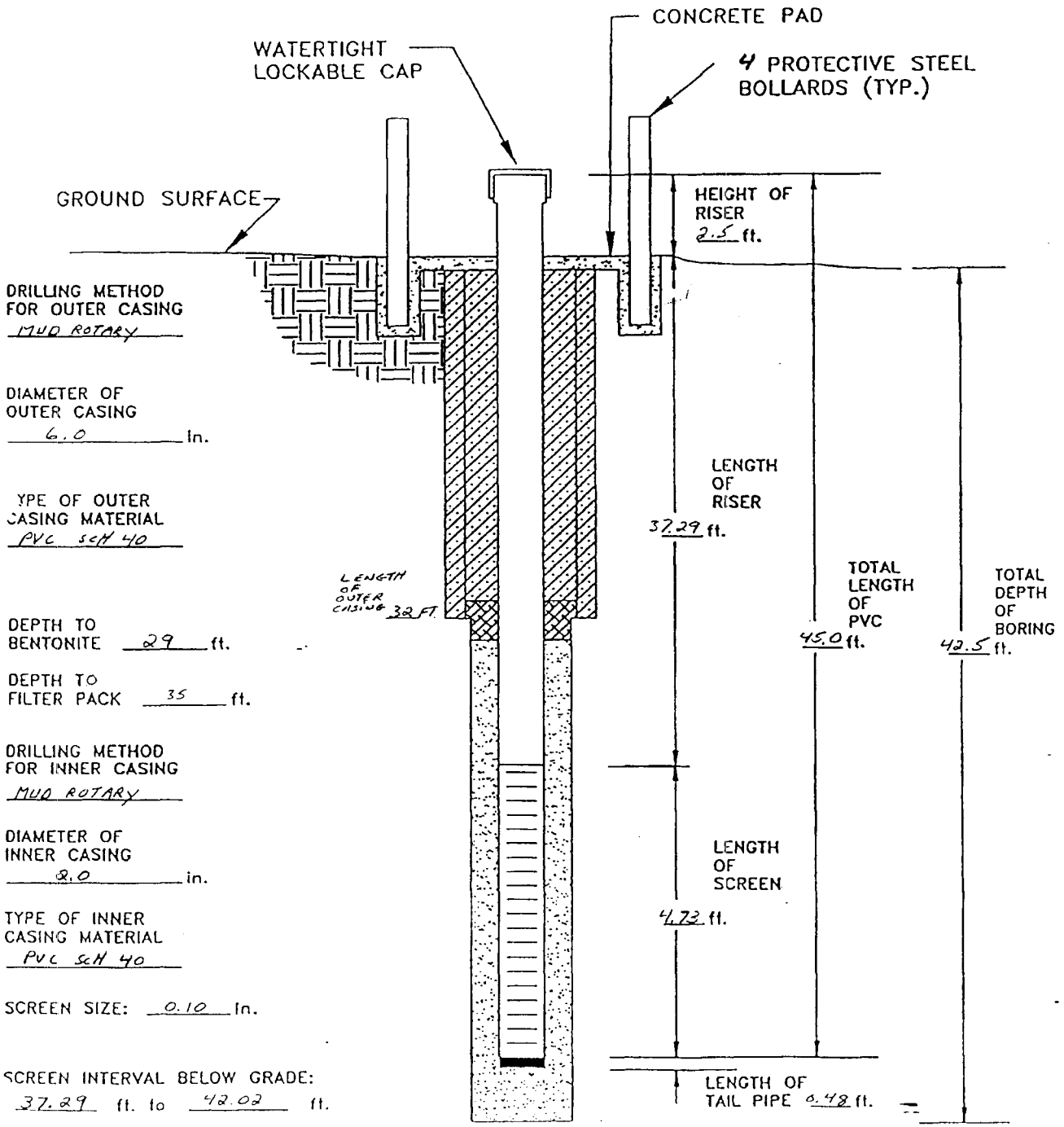

BAKER ENVIRONMENTAL REPRESENTATIVE: KENNETH A. TUA

ATTACHMENT B
LABORATORY ANALYTICAL REPORT

Mr. Bill Morris
Engineering & Environment, Inc.
824 Gum Branch Road
Jacksonville NC 28546

Report Number: G546-50

Client Project: CSFF

Dear Mr. Morris:

Enclosed are the results of the analytical services performed under the referenced project. The samples are certified to meet the requirements of the National Environmental Laboratory Accreditation Conference Standards. Copies of this report and supporting data will be retained in our files for a period of five years in the event they are required for future reference. Any samples submitted to our laboratory will be retained for a maximum of thirty (30) days from the date of this report unless other arrangements are requested.

If there are any questions about the report or the services performed during this project, please call Paradigm at (910) 350-1903. We will be happy to answer any questions or concerns which you may have.

Thank you for using Paradigm Analytical Labs for your analytical services. We look forward to working with you again on any additional analytical needs which you may have.

Sincerely,
Paradigm Analytical Laboratories, Inc.

Laboratory Director
J. Patrick Weaver

Date

Results for Total Petroleum Hydrocarbons
by GC/FID 8015

Client Sample ID: CSFF-S002
 Client Project ID: CSFF
 Lab Sample ID: G546-50-2
 Lab Project ID: G546-50
 Report Basis: Dry Weight

Analyzed By: DCS
 Date Collected: 8/17/05 12:50
 Date Received: 8/17/05
 Matrix: Soil
 Solids 79.85

Analyte	Result MG/KG	Report Limit MG/KG	Prep Method	Dilution Factor	Date Analyzed
Gasoline Range Organics	376	29.5	5035	5	08/18/05
Diesel Range Organics	2770	155	3545	20	08/18/05

Comments:

Results for Total Petroleum Hydrocarbons
by GC/FID 8015

Client Sample ID: CSFF-S003
Client Project ID: CSFF
Lab Sample ID: G546-50-3
Lab Project ID: G546-50
Report Basis: Dry Weight

Analyzed By: DCS
Date Collected: 8/17/05 12:55
Date Received: 8/17/05
Matrix: Soil
Solids 87.06

Analyte	Result MG/KG	Report Limit MG/KG	Prep Method	Dilution Factor	Date Analyzed
Gasoline Range Organics	6.7	5.77	5035	1	08/18/05
Diesel Range Organics	31.1	7.14	3545	1	08/18/05

Comments:

Results for Total Petroleum Hydrocarbons
by GC/FID 8015

Client Sample ID: CSFF-S004
Client Project ID: CSFF
Lab Sample ID: G546-50-4
Lab Project ID: G546-50
Report Basis: Dry Weight

Analyzed By: DCS
Date Collected: 8/17/05 13:00
Date Received: 8/17/05
Matrix: Soil
Solids 84.70

Analyte	Result MG/KG	Report Limit MG/KG	Prep Method	Dilution Factor	Date Analyzed
Gasoline Range Organics	647	230	5035	50	08/18/05
Diesel Range Organics	21200	1840	3545	250	08/18/05

Comments:

List of Reporting Abbreviations and Data Qualifiers

B = Compound also detected in batch blank

BQL = Below Quantitation Limit

DF = Dilution Factor

Dup = Duplicate

E = Estimated concentration, exceeds calibration range.

J = Estimated concentration, below calibration range and above MDL

LCS(D) = Laboratory Control Spike (Duplicate)

MDL = Method Detection Limit

MS(D) = Matrix Spike (Duplicate)

PQL = Practical Quantitation Limit

RL = Reporting Limit

RPD = Relative Percent Difference

mg/kg = milligram per kilogram, ppm, parts per million

ug/kg = micrograms per kilogram, ppb, parts per billion

mg/L = milligram per liter, ppm, parts per million

ug/L = micrograms per liter, ppb, parts per billion

% Rec = Percent Recovery

% solids = Percent Solids

Special Notes:

- 1) Metals and mercury samples are digested with a hot block, see the standard operating procedure document for details.
- 2) Uncertainty for all reported data is less than or equal to 30 percent.

