

**APPENDIX C**  
**FIELD LOG BOOK SKETCHES**

**Table C-1  
Visual Site Inspection Unit List**

<b>Site Number</b>	<b>Page No.</b>	<b>Roll-Photo</b>	<b>Unit Name</b>
A8-HWA	1	10-00	2nd Amphibious Assault Battalion, 2nd Marine Division
A47-HWA	2	1-2	2nd Amphibious Assault Battalion, 2nd Marine Division
SA42-O/W	2	1-3	2nd Amphibious Assault Battalion
A47-0/W-1	2	1-4	2nd Amphibious Assault Battalion, 2nd Marine Division
A47-0/W-2	2	1-5	2nd Amphibious Assault Battalion, 2nd Marine Division
SFC268-O/W	3	1-6	Supply Battalion, 2nd FSSG
SFC233-HWA	3	1-7	Supply Battalion, 2nd FSSG
SFC234-HWA	4	1-8	2nd Medical Battalion, 2nd FSSG
FC238-HWA	5	1-10	H&S Battalion, 2nd FSSG
FC255-O/W	5	1-11	H&S Battalion, 2nd FSSG
SFC283-HWA	6	1-13	Maintenance Battalion, 2nd FSSG
SFC282-HWA	6	1-14	Maintenance Battalion, 2nd FSSG
FC280-O/W	6	1-15	Maintenance Battalion, 2nd FSSG
FC281-O/W	7	1-16	Maintenance Battalion, 2nd FSSG
FC285-AST	8	1-17	Maintenance Battalion, 2nd FSSG
FC285-HWA	8	1-17	Maintenance Battalion, 2nd FSSG
SFC37-HWA	9	1-18	Motor Transport, 2nd FSSG
FC40-O/W	9	1-19	Motor Transport, 2nd FSSG
SFC46-HWA	10	1-20	Operation Readiness Float, 2nd FSSG
FC45-O/W	10	1-21	Operation Readiness Float, 2nd FSSG
FC51-HWA	11	1-22	Electronics Maintenance Company, 2nd FSSG
FC51-0/W	11	1-22	Electronics Maintenance Company, 2nd FSSG
1601-HWA	12	1-23	Motor Transport Maintenance, 2nd FSSG
902-HWA	13	1-24/ 25	Engineer Maintenance Company, 2nd FSSG
902-AST	13	1-24/ 25	8th Engineers, 2nd FSSG
816-O/W	14	1-26/ 27	8th Engineers, 2nd FSSG

**Table C-1  
Visual Site Inspection Unit List**

<b>Site Number</b>	<b>Page No.</b>	<b>Roll-Photo</b>	<b>Unit Name</b>
GP190-O/W	15	1-28/ 29	8th Engineers, 2nd FSSG
739-O/W	16	1-30	8th Engineers, 2nd FSSG
SFC221-HWA	17	1-31	8th Engineers, 2nd FSSG
FC200-O/W	18	1-32	8th Engineers, 2nd FSSG
FC120-HWA	19	1-33	Land Support Battalion, 2nd FSSG
FC120-O/W	19	1-34	Land Support Battalion, 2nd FSSG
SFC145-HWA	19	1-35	Land Support Battalion, 2nd FSSG
FC134-O/W	20	1-36	Land Support Battalion, 2nd FSSG
FC134-HWA	20	1-37	Land Support Battalion, 2nd FSSG
FC270-O/W	21	2-1	8th Motor Transport, 2nd FSSG
SFC279-HWA	22	2-2	8th Motor Transport, 2nd FSSG
Release (FC270)	22	None	8th Motor Transport, 2nd FSSG
M119-O/W	23	6-1	Marine Corps Support Services School Group
SM93-HWA	23	6-2	Marine Corps Support Services School Group
M144-HWA-AST	24	6-3	Marine Corps Support Services School Group
M90-HWA	25	6-4	Marine Corps Support Services School Group
SM187-O/W	26	6-5/6	Marine Corps Support Services School Group
1805-HWA	27	6-7	2nd Combat Engineer Battalion, 2nd Marine Division
1859-O/W	27	6-8/9	2nd Combat Engineer Battalion, 2nd Marine Division
1895-HWA-1	28	6-10	2nd Combat Engineer Battalion, 2nd Marine Division
1895-HWA-2	28	6-11	2nd Combat Engineer Battalion, 2nd Marine Division
1041-HWA	29	6-12	MCB Brig Company
1203-O/W	30	2-3	MCB Maintenance
1105-O/W	31	2-4	MCB Maintenance
1102/1131-HWA	32	2-5	MCB Maintenance
1700-O/W-1	33	2-6	MCB Maintenance

**Table C-1**  
**Visual Site Inspection Unit List**

<b>Site Number</b>	<b>Page No.</b>	<b>Roll-Photo</b>	<b>Unit Name</b>
1700-O/W-2	33	2-7	MCB Maintenance
S1735-O/W	34	2-8/9	MCB Maintenance
738-O/W	35	2-10	MCB Maintenance
45-HWA	36	2-11	MCB Maintenance
SLCH785-Basin	36	2-12	MCB Maintenance
S792-O/W	36	2-13	MCB Maintenance
1403-HWA	37	2-15	Training and Support Division
S1762-HWA	38	2-16	Morale, Welfare, and Recreation
TC773-O/W	39	2-17	School of Infantry
TC773-HWA	39	2-18	School of Infantry
TC777-O/W	40	2-19	School of Infantry
G694-O/W-Rack	41	2-20/ 21/22	MCB Maintenance
SAS137-Basin	42	2-24	Marine Corps Air Station
M628-O/W	43	2-25	MCB Maintenance
RR62-HWA	44	2-26	Rifle Range
SRR80-O/W	45	2-27	Rifle Range
RR15-O/W-1	46	2-28	MCB Maintenance
RR15-O/W-2	46	2-29	MCB Maintenance
M178-HWA	47	2-30	Field Medical Services
FC230-O/W-1	48	10-0/1	8th Communication Battalion, 2nd SRIG
FC230-O/W-2	49	3-2	8th Communication Battalion, 2nd SRIG
SFC235-HWA	49	3-3	8th Communication Battalion, 2nd SRIG
1605-HWA-1	50	3-4	8th Communication Battalion (Alpha Co-Radio), 2nd SRIG
1605-HWA-2	50	3-5	8th Communication Battalion (MagTaf), 2nd SRIG
S1619-O/W	50	3-6	8th Communication Battalion, 2nd SRIG
1604-HWA	50	3-7	8th Communication Battalion, 2nd SRIG
1771-HWA-AST	51	3-8	Headquarters & Service Company, 2nd Marine Expeditionary Forces
SFC237-HWA	52	3-9	2nd Anglico, 2nd SRIG
FC251-O/W	52	3-10	2nd Anglico, 2nd SRIG

**Table C-1**  
**Visual Site Inspection Unit List**

Site Number	Page No.	Roll-Photo	Unit Name
1747-O/W-1	53	3-11	2nd Unmanned Aerial Vehicle, 2nd SRIG
1747-O/W-2	53	3-12	2nd Unmanned Aerial Vehicle, 2nd SRIG
FC365-HWA	54	3-13	2nd Radio Battalion, 2nd SRIG
SFC244-O/W	55	3-14	2nd Radio Battalion (Motor Transport), 2nd SRIG
SFC236-HWA	55	3-15	2nd Radio Battalion (Motor Transport), 2nd SRIG
FC241-AST	55	3-15	2nd Radio Battalion (Motor Transport), 2nd SRIG
S1746-HWA	53	3-16	2nd Unmanned Aerial Vehicle, 2nd SRIG
1827-HWA-1	56	3-17	Intelligence Company 2nd SRIG
1827-HWA-2	56	3-18	Intelligence Company, 2nd SRIG
SM632-O/W	57	3-19	Base Maintenance
M107-O/W-1	58	3-20	Motor Transport School Company.
M107-O/W-2	58	3-21	Motor Transport School Company.
SM269-Basin	59	3-22	Unknown
M200-AST	59	10-7	Unknown
1860-O/W	60	3-23	Communication Company, Headquarters Battalion, 2D Marine Division
S1892-HWA	60	3-24	Communication Company, Headquarters Battalion, 2D Marine Division
1780-HWA	61	3-25	Truck Company Maintenance, Headquarters Battalion, 2D Marine Division
1780-O/W-1	61	3-26	Truck Company Maintenance, Headquarters Battalion, 2D Marine Division
1780-O/W-2	61	3-27	Truck Company Maintenance, Headquarters Battalion, 2D Marine Division
1780-UST-1	61	3-26	Truck Company Maintenance, Headquarters Battalion, 2D Marine Division
1780-O/W-3	61	3-29	Truck Company Maintenance, Headquarters Battalion, 2D Marine Division
1780-UST-2	61	3-28	Truck Company Maintenance, Headquarters Battalion, 2D Marine Division

**Table C-1  
Visual Site Inspection Unit List**

Site Number	Page No.	Roll-Photo	Unit Name
S1753-O/W-AST	62	10-2	Small Craft Company, Headquarters, 2D Marine Division
S1745-O/W	63	4-2	Truck Company Maintenance, Headquarters Battalion, 2D Marine Division
728-AST	64	4-3	Marina Gottschalk
1601-AST	65	4-4	2nd FSSG
1601-O/W	66	4-5	Unknown
1700-Pond-A	67	4-6	MCB Maintenance
1700-Basin-B	67	4-7	Base Maintenance
FC19-Rack	68	4-8	Unknown
S1836-HWA	69	4-9	6th Marines Regiment, 2nd Marine Division
1829-O/W-1	69	4-10	6th Marines Regiment, 2nd Marine Division
1829-O/W-2	69	4-11	6th Marines Regiment, 2nd Marine Division
P804-O/W-1	70	4-12	Unknown
P804-O/W-2	70	4-13	Unknown
FC285-O/W	71	4-14	Unknown
SFC284-HWA	71	4-15	Unknown
AS415-Basin	72	2-23	MCB Maintenance
S1854-O/W-1	B001	5-2	2nd Tank Battalion, 2nd Marine Division
S1854-O/W-2	B001	5-3	2nd Tank Battalion, 2nd Marine Division
S1854-HWA	B002	5-1	2nd Tank Battalion, 2nd Marine Division
S1854-UST-2	B003	None	2nd Tank Battalion, 2nd Marine Division
S1854-UST-1	B003	None	2nd Tank Battalion, 2nd Marine Division
1205-AST	B004	5-4	H&S Company, 2nd Marine Expeditionary Forces
1205-HWA	B004	5-4	H&S Company, 2nd Marine Expeditionary Forces
H36-Rack	B005	None	Engineering Maintenance Section, 2nd Marine Expeditionary Forces
H36-HWA	B005	5-5	Engineering Maintenance Section, 2nd Marine Expeditionary Forces
H36-AST	B005	5-5	Engineering Maintenance Section, 2nd Marine Expeditionary Forces

**Table C-1  
Visual Site Inspection Unit List**

Site Number	Page No.	Roll-Photo	Unit Name
BB51-O/W	B006	5-6	MC Engineering School
BB150-O/W	B007	5-7	MC Engineering School
BB51-HWA	B008	5-8	MC Engineering School
BB51-AST	B009	5-9	MC Engineering School
BB52-O/W-2	B010	5-10	MC Engineering School
SBB135-HWA	B011	5-11	MC Engineering School
SBB169-O/W	B012	5-12	MC Engineering School
SBB169-AST	B012	5-13	MC Engineering School
SBB241-O/W	B013	5-14	MC Engineering School
BB293-O/W	B014	5-15	MC Engineering School
HP100-O/W	B015	5-16	Motor T, 8th Marine Regiment, 2nd Marine Division
HP100-UST	B015	5-19	Motor T, 8th Marine Regiment, 2nd Marine Division
HP100-HWA	B016	5-17/ 18	8th Marine Regiment, 2nd Marine Division
HP104-HWA	B017	None	Communication Center, 8th Marine Regiment, 2nd Marine Division
1450-HWA	B018	5-21	5/10th Artillery Battalion, 10th Marine Regiment, 2nd Marine Division
1450-O/W-1	B019	5-22	5/10th Artillery Battalion, 10th Marine Regiment, 2nd Marine Division
1450-O/W-2	B020	5-23	5/10th Artillery Battalion, 10th Marine Regiment, 2nd Marine Division
034 Ditch	B021	5-24	5/10th Artillery Battalion, 10th Marine Regiment, 2nd Marine Division
BB224-File	B022	5-25	Unknown
BB9-O/W	B023	5-26	MCB Steam Plant
BB9-Basin	B023	5-27	MCB Steam Plant
2611-Container	B024	5-28	MCB Parking Lot
HP250-O/W	B025	5-29	2nd Marine Division
HP250-HWA	B026	5-30	2nd Marine Division
HP250-AST	B026	5-30	2nd Marine Division
HP250-O/W-2	B027	5-31	32nd Communication, 2nd Marine Division
H118-O/W	B028	5-32	Naval Hospital

**Table C-1  
Visual Site Inspection Unit List**

<b>Site Number</b>	<b>Page No.</b>	<b>Roll-Photo</b>	<b>Unit Name</b>
NH118-UST	B029	None	Naval Hospital
NH118-HWA	B029	5-33	Naval Hospital
2615-O/W	B030	5-34	MCB O' Club
PT33-Pond-O/W	B031	5-35	MCB
PT33-Pile	B031	5-36	MCB
908-HWA	B032	6-13	Logistic
961-O/W	B033	6-14	Logistic
1407/1408-O/W	B034	6-15	Logistic
1502-O/W-1	B035	6-16/ 17	Logistic
1502-HWA	B036	6-18	Logistic
1502-O/W-2	B036	6-35	Logistic
TC364-Basin	B037	6-19	Logistic
AS118-O/W	B038	6-20 8-32	Logistic
AS22-O/W	B039	6-21	2nd Amphibious Assault Battalion, 2nd Marine Division
AS22-Pile	B040	6-22	2nd Amphibious Assault Battalion, 2nd Marine Division
SA16-O/W	B041	6-23	2nd Amphibious Assault Battalion, 2nd Marine Division
SA36-O/W	B042	6-24	2nd Amphibious Assault Battalion, 2nd Marine Division
A1-HWA	B043	6-25	2nd Amphibious Assault Battalion, 2nd Marine Division
A1-Rack	B044	6-26	2nd Amphibious Assault Battalion, 2nd Marine Division
ST32-Pile	B045	6-28	MCB Maintenance
TT2453-Release	B046	6-29	MCB Auto Hobby Tarawa Terrace
TT2453-AST	B046	6-29	MCB Auto Hobby Tarawa Terrace
TT2453-HWA	B046	6-29	MCB Auto Hobby Tarawa Terrace
BA130-AST	B047	None	Motor T - 2nd Reconnaissance Battalion, 2nd Marine Division
BA130-O/W	B047	6-30	Motor T - 2nd Reconnaissance Battalion, 2nd Marine Division
BA130-HWA	B048	6-31	Motor T - 2nd Reconnaissance Battalion, 2nd Marine Division



**Table C-1**  
**Visual Site Inspection Unit List**

Site Number	Page No.	Roll-Photo	Unit Name
1053-O/W	B049	6-32	Morale, Welfare, and Recreation Car Wash
S1001-Basin	B050	6-33	MCB Rail Head
S1132-O/W	B051	6-34	Unknown
1610-O/W	B052	6-36/ 37	MCB Auto Shop
575-AST	B053	None	Motor T, 2nd Light Armory Infantry Battalion, 2nd Marine Division
575-O/W	B053	None	Motor T, 2nd Light Armory Infantry Battalion, 2nd Marine Division
575-HWA	B053	None	Motor T, 2nd Light Armory Infantry Battalion, 2nd Marine Division
575-UST	B053	None	Motor T, 2nd Light Armory Infantry Battalion, 2nd Marine Division
575-Rack	B054	None	Motor T, 2nd Light Armory Infantry Battalion, 2nd Marine Division
540-Backwash	B055	7-2	MCB Pool
236-Backwash	B056	7-3	MCB Pool
25-O/W	B057	7-4	MCB Dry Cleaners
43-AST	B058	7-5	MCB Security
1014-Container	B059	7-6/7	MCB Former PCB Storage Yard
946-UST	B060	7-13	MCB Recycling Center
S947-Pile	B061	7-8/9	MCB Recycling Center
S947-O/W	B062	7/10/ 11	MCB Recycling Center
S946-AST	B063	7-12	MCB Recycling Center
S947-Container	B064	7-14	MCB Recycling Center
913-AST	B065	7-15	MCB Recycling Center
TP45-AST	B066	7-18	MCB Truck Driving School
TP45-Rack	B067	7-19	MCB Truck Driving School
1916-O/W	B068	7-20	MCB Golf Course
600-UST	B069	None	MCB Golf Course
1775-HWA	B070	7-21	1st/2nd/3rd BN-Maintenance, 10th Marine Regiment, 2nd Marine Division
1775-O/W-UST	B071	7-22	1st/2nd/3rd BN-Maintenance, 10th Marine Regiment, 2nd Marine Division

**Table C-1  
Visual Site Inspection Unit List**

Site Number	Page No.	Roll-Photo	Unit Name
1775-UST	B072	7-23/ 24/25	1st/2nd/3rd BN-Maintenance, 10th Marine Regiment, 2nd Marine Division
1445-O/W	B073	7-26	Communication, 10th Marine Regiment, 2nd Marine Division
1343-O/W	B074	7-27	HQ Motor T, 10th Marine Regiment, 2nd Marine Division
1327/1343-HWA	B075	7-28	HQ Motor T, 10th Marine Regiment, 2nd Marine Division
1323-UST	B076	7-29	HQ Battery-Motor T, 10th Marine Regiment, 2nd Marine Division
1106/1107-AST	B077	7-30	Motor T Auto Hobby
1106/1107-UST	B077	7-31	Motor T Auto Hobby
1106/1107-O/W	B077	7-32	Motor T Auto Hobby
1205/1206-O/W	B078	7-33	Motor T, H&S Company, 2nd Marine Expeditionary Forces
1301/1309-AST	B079	7-34	HQ & Service Company, 2nd SRIG
1301/1309-O/W	B079	7-34	HQ & Service Company, 2nd SRIG
1405/1406-O/W	B080	8-2	Unknown
1612-AST	B081	None	Motor T
1505/1506-O/W	B082	8-0	Motor T
1505/1506-AST	B082	8-0	Unknown
AS431-HWA	B083	8-4	HMT 204/HMH 362, MAG-26, 2nd Marine Aircraft Wing
AS431-AST	B083	8-4	HMT 204/HMH 362, MAG-26, 2nd Marine Aircraft Wing
AS504-O/W	B084	8-5	HMT 204, MAG-26, 2nd Marine Aircraft Wing
AS504-AST	B085	8-6	HMH 362, MAG-26, 2nd Marine Aircraft Wing
AS515-HWA-E	B086	8-7	HMM 266/ HMM 261, MAG-26, 2nd Marine Aircraft Wing
AS515-AST-E	B086	8-7	HMM 266/HMM 261, MAG-26, 2nd Marine Aircraft Wing
AS574-HWA	B087	8-8	HMM 261, MAG-26, 2nd Marine Aircraft Wing
AS574-AST	B087	8-8	HMM 261, MAG-26, 2nd Marine Aircraft Wing
AS525-AST	B088	8-9	MALS 26 Maintenance, MAG-26, 2nd Marine Aircraft Wing

**Table C-1  
Visual Site Inspection Unit List**

Site Number	Page No.	Roll-Photo	Unit Name
AS525-HWA	B088	8-9	MALS 26 Maintenance, MAG-26, 2nd Marine Aircraft Wing
AS3905-HWA	B089	8-10	HMH 461/HMH 464, MAG-26/29, 2nd Marine Aircraft Wing
AS3905-AST	B089	8-11	HMH 461/HMH 464, MAG-26/29, 2nd Marine Aircraft Wing
AS3905-O/W	B090	8-12	HMH 461/HMH 464, MAG-26/29, 2nd Marine Aircraft Wing
AS4112-AST	B091	None	HMM 365, MAG-29, 2nd Marine Aircraft Wing
AS4112-HWA	B091	8-13	HMM 365, MAG-29, 2nd Marine Aircraft Wing
AS4134-HWA	B092	8-14	MALS 29 Maintenance, MAG-29, 2nd Marine Aircraft Wing
AS4114-AST	B093	8-15	MALS 29 Maintenance, MAG-29, 2nd Marine Aircraft Wing
AS4114-HWA	B093	8-15	MALS 29 Maintenance, MAG-29, 2nd Marine Aircraft Wing
AS4108-AST	B094	8-16	HMLA 269, MAG-29, 2nd Marine Aircraft Wing
AS4115-AST	B095	8-17	HMLA 167/HMM 263, MAG-26/29, 2nd Marine Aircraft Wing
AS4115-HWA	B095	8-18	HMLA 167/HMM 263, MAG-26/29, 2nd Marine Aircraft Wing
AS4135-O/W	B096	10-10	MALS 29 GSE, MAG-29, 2nd Marine Aircraft Wing
AS4135-HWA	B096	10-9	MALS 29 GSE, MAG-29, 2nd Marine Aircraft Wing
AS4135-UST	B096	8-19	MALS 29 GSE, MAG-29, 2nd. Marine Aircraft Wing
AS226-Still	B097	None	MCAS
AS515-O/W	B098	8-20/ 21	HMH 362, MAG-26, 2nd Marine Aircraft Wing
AS576-O/W	B099	8-22	HMM 365, MAG-29, 2nd Marine Aircraft Wing
AS576-AST	B099	8-22	HMM 365, MAG-29, 2nd Marine Aircraft Wing
AS-Pit-UST	B100	8-23	MCAS
AS-Pit-O/W	B100	None	MCAS
AS592-O/W	B101	8-24	MCAS Engine Test Cell, HMLA 269, MAG-29, 2nd Marine Aircraft Wing

**Table C-1**  
**Visual Site Inspection Unit List**

Site Number	Page No.	Roll-Photo	Unit Name
AS499-O/W	B102	8-25 9-11	MCAS
AS4159-O/W	B103	8-26	MWSS272, MWSG-27, 2nd Marine Aircraft Wing
AS4159-AST	B103	8-27	MWSS272, MWSG-27, 2nd Marine Aircraft Wing
AS4158-O/W	B104	8-28	MWSS272, MWSG-27, 2nd Marine Aircraft Wing
AS4158-HWA	B105	8-29	MWSS272, MWSG-27, 2nd Marine Aircraft Wing
AS143-O/W	B106	8-30	MCAS Supply Dept.
AS119-Rack	B107	8-31	MCAS Base Motor T
AS123-O/W	B108	None	Morale, Welfare, and Recreation
AS118-AST	B110	8-33	Motor T, MCB Logistic
AS114-AST	B111	8-34/ 35	MCAS Auto Hobby Shop
AS320-AST	B112	9-0	MCAS Flight Simulator
AS605-HWA	B113	9-1	MCAS < 90 Day H.W. Accumulation Area
AS605-O/W	B113	9-1	MCAS < 90 Day H.W. Accumulation Area
AS605-UST	B113	9-1	MCAS < 90 Day H.W. Accumulation Area
CG1-O/W	B114	9-2	MATCS-28, MACG-28, 2nd Marine Aircraft Wing
CG1-UST	B114	9-3	MATCS-28, MACG-28, 2nd Marine Aircraft Wing
AS4158-AST	B115	9-4	MWSS272, MWSG-27, 2nd Marine Aircraft Wing
AS-Curtis-Ditch	B116	9-6	MCAS Drainage Ditch Curtis Road
AS-Longstaff-Ditch	B117	9-7	MCAS Drainage Ditch longstaff Road
AS3504-AST	B118	None	MCAS AST
SAS3503-AST	B118	9-8	MCAS AST
SAS3503-O/W	B118	9-8	MCAS
AS3003-Ditch	B119	9-9	MCAS Drainage Ditch
AS-Primington-Ditch	B120	9-10	MCAS Drainage Ditch Primington Road

**Table C-1**  
**Visual Site Inspection Unit List**

Site Number	Page No.	Roll-Photo	Unit Name
AS5020-Ditch	B122	9-12	MCAS Drainage Ditch By Ordnance
STC874-O/W	B123	9-13	MCAS DRMO
STC868-Rack	B123	9-14	MCAS DRMO
STC872-Pile	B123	9-15	MCAS DRMO
TC811-O/W	B124	9-16	MCB Security
SM264-Rack	B125	9-17	Unknown
M105-Rack	B126	9-18	Unknown
SA45-O/W	B127	9-22	2nd. Amphibious Assault Battalion
45-Pond	B128	9-19/ 20	MCB
45-AST-2	B129	9-21	MCB
BB161-UST	B130	9-23/ 24	MC Engineer. School
BB190-Backwash	B131	9-25	MCB
BB177-AST	B131	9-26	Morale Welfare and Recreation
AS141-O/W	B133	None	MCB
907-HWA	B134	10-3	Medlog, 2nd Supply Battalion, 2nd FSSG
915-HWA	B135	10-5	2nd Supply Battalion, 2nd FSSG
SF97-HWA-AST	B136	10-6	MSSG-22, 2nd FSSG
AS4117-HWA	B137	10-8	HMM 162, MAG-29, 2nd Marine Aircraft Wing

A-0

All photos referred to herein taken  
with a Canon - Snappy 30, 35mm  
camera.

A-1

2d AA Battalion

11-15-93

Site #3

Photo 1, Roll 1

<90 H.W. Site

0900

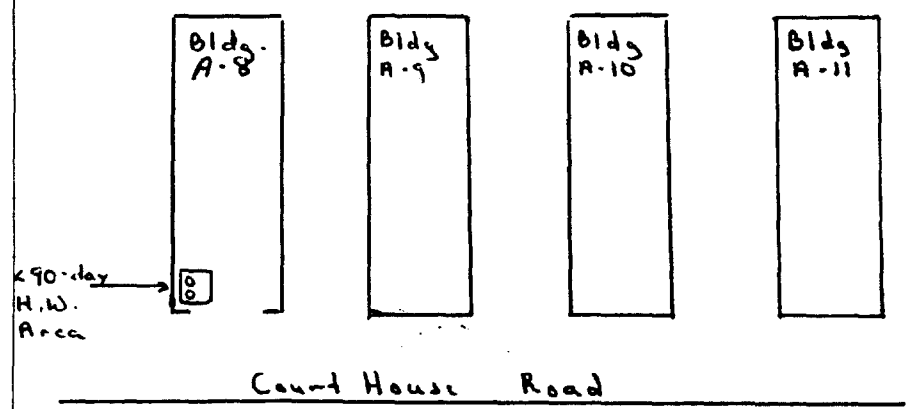

A 2

11-15-93  
0900

2d AA Battalion

Site #2 - 490 H.W. Unit

Photo 2, Roll 1

SA 42 - O/W Separator

Photo 3, Roll 1

Unknown - O/W Separator

Photo 4, Roll 1

Unknown - O/W Separator

Photo 5, Roll 1

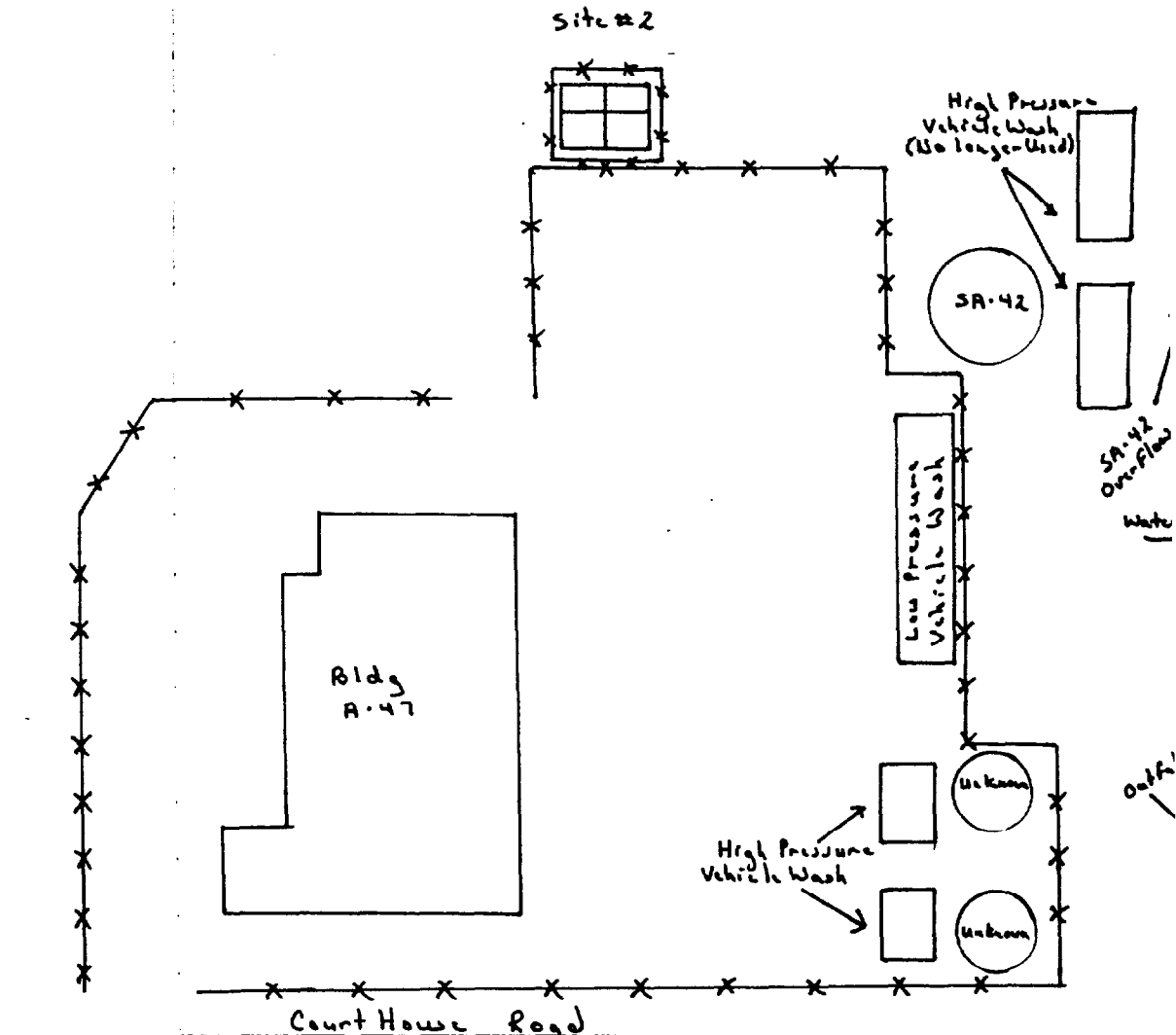



A3

11-16-93

2d FSSG Supply Battalion  
SFC-268 - O/W Separator  
SFC-233 - < 90 H.W. Unit

0800  
Photo 6, Roll 1  
Photo 7, Roll 1

Gonzalez

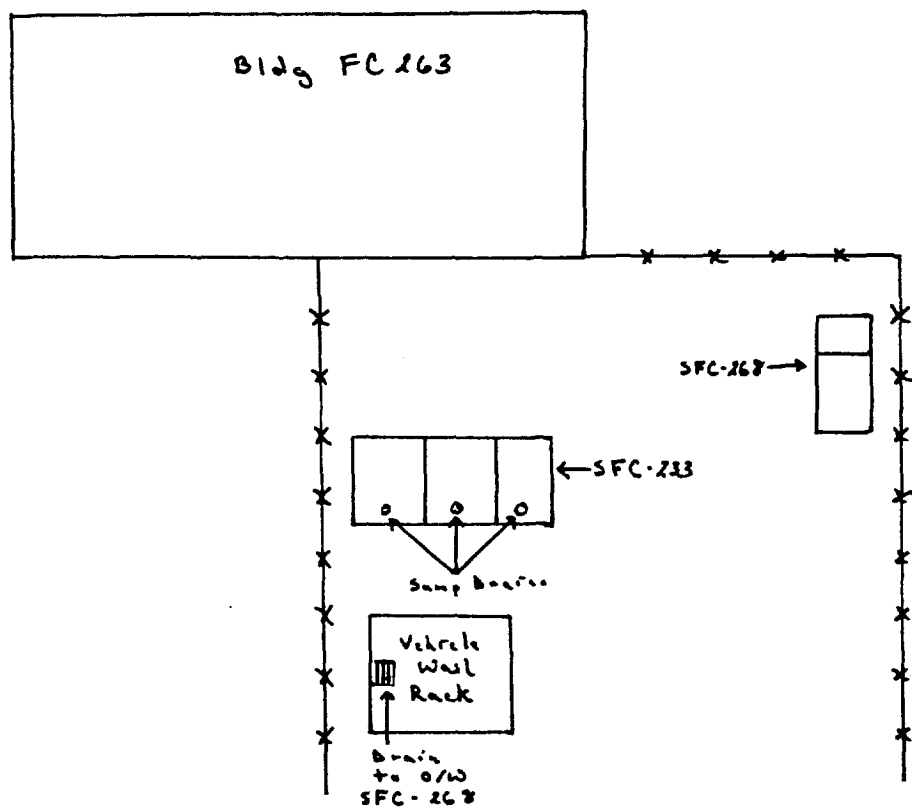

A4

11-16-93  
0800

2d FSSG 2d Medical Battalion

SFC 234 - 490 H.W. Unit

Photo 8, Roll 1

Gonzalez

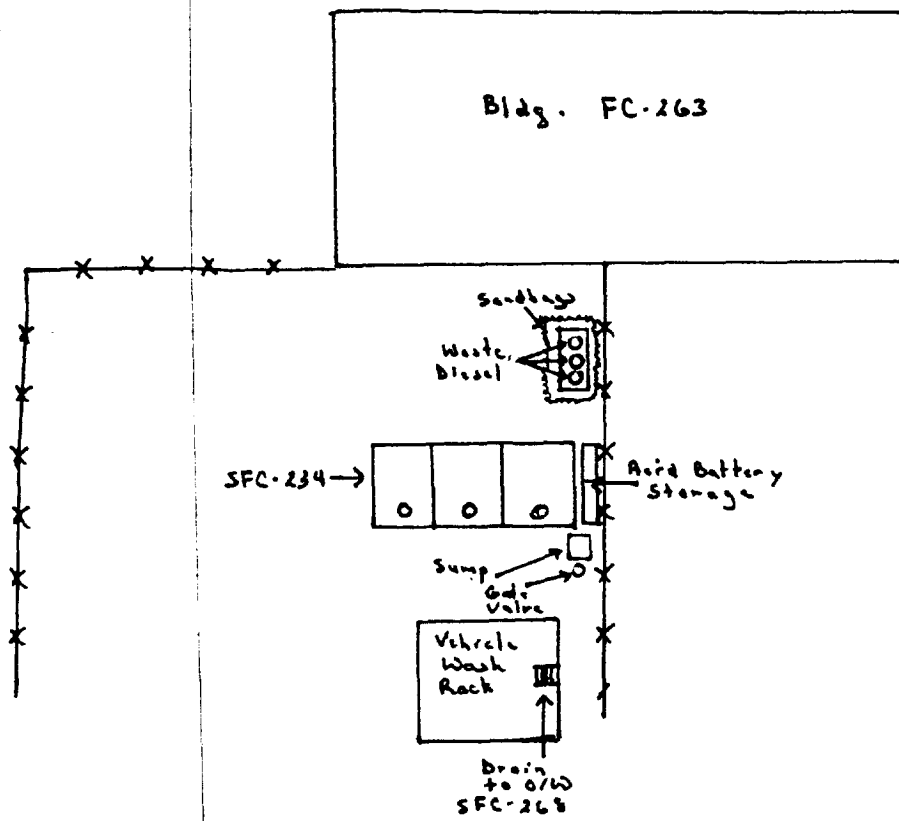

A 5  
11:16.93  
0930

2d FSSG H+S Battalion

FC-255<sup>room</sup>

SFC-238 - 490 H.W. Unit

Photo 10, Roll 1

FC-255 - O/W Separator

Photo 11, Roll 1

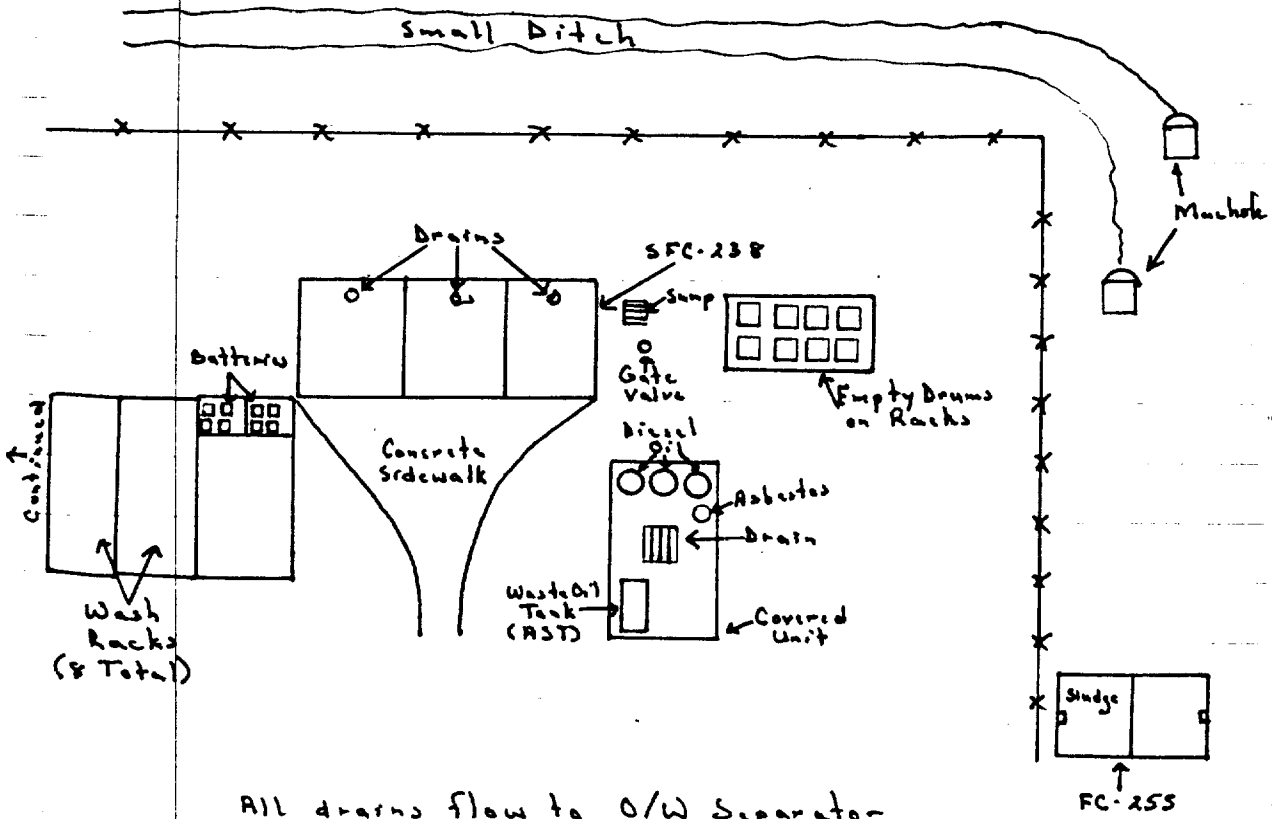

A 6

11-16-93  
1300

2d FSSG Maintenance Battalion

SFC-283 - < 90 H.W. Unit

Photo 13, Roll 1

SFC-282 - < 90 H.W. Unit

Photo 14, Roll 1

Unknown (FC-280) - O/W Separator

Photo 15, Roll 1

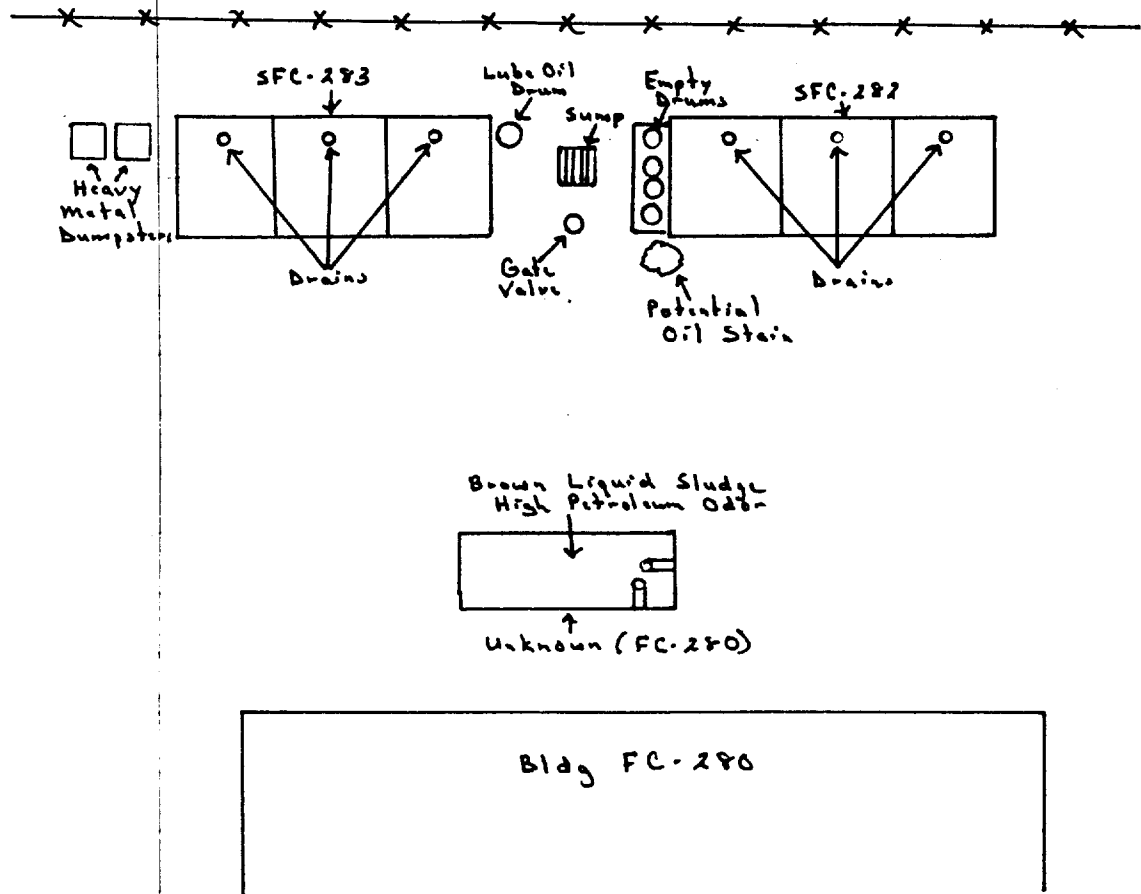

A 7  
11-16-93  
1345

2d FSSG Maintenance Battalion  
SC  
FC-281 - O/W Separator

Photo 16, Roll 1

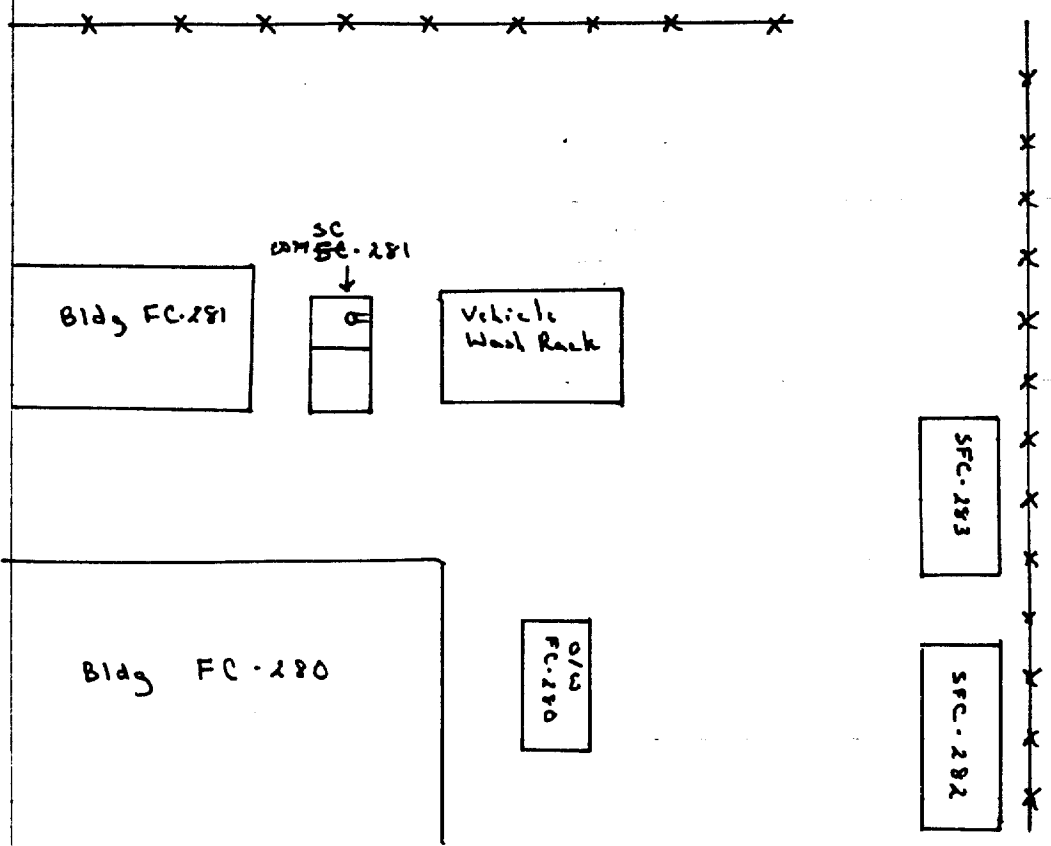



A9  
11-17-93  
0800

2d FSSG Motor Transport  
SFC-37 - < 90 H.W. Unit  
FC-40 - O/W Separator

Photo 18, Roll 1  
Photo 19, Roll 1

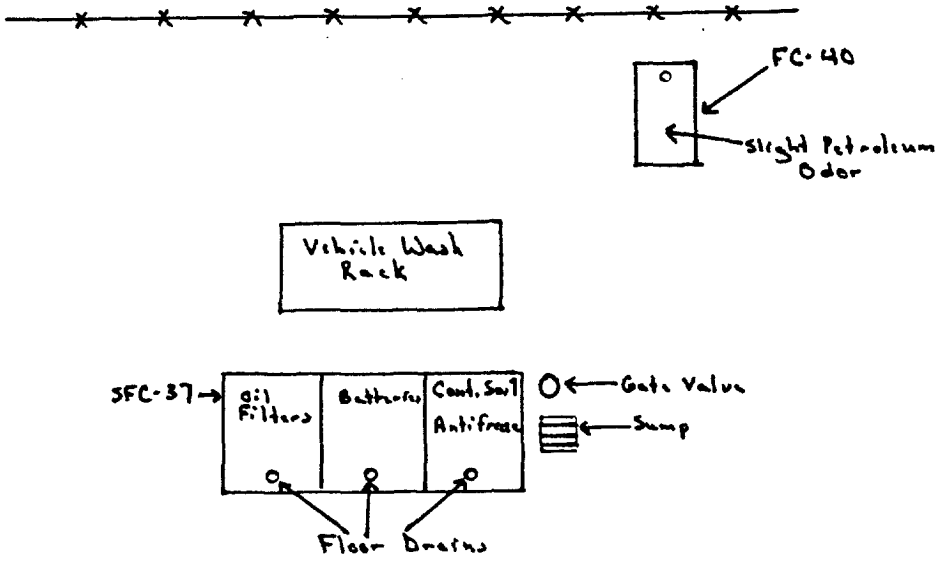

A 10

11-17-93  
0900

2d FSSG Operation Readiness Float

SFC-46 - 490 H.W. Unit

Photo 20, Roll 1

FC-45 - O/W Separator

Photo 21, Roll 1

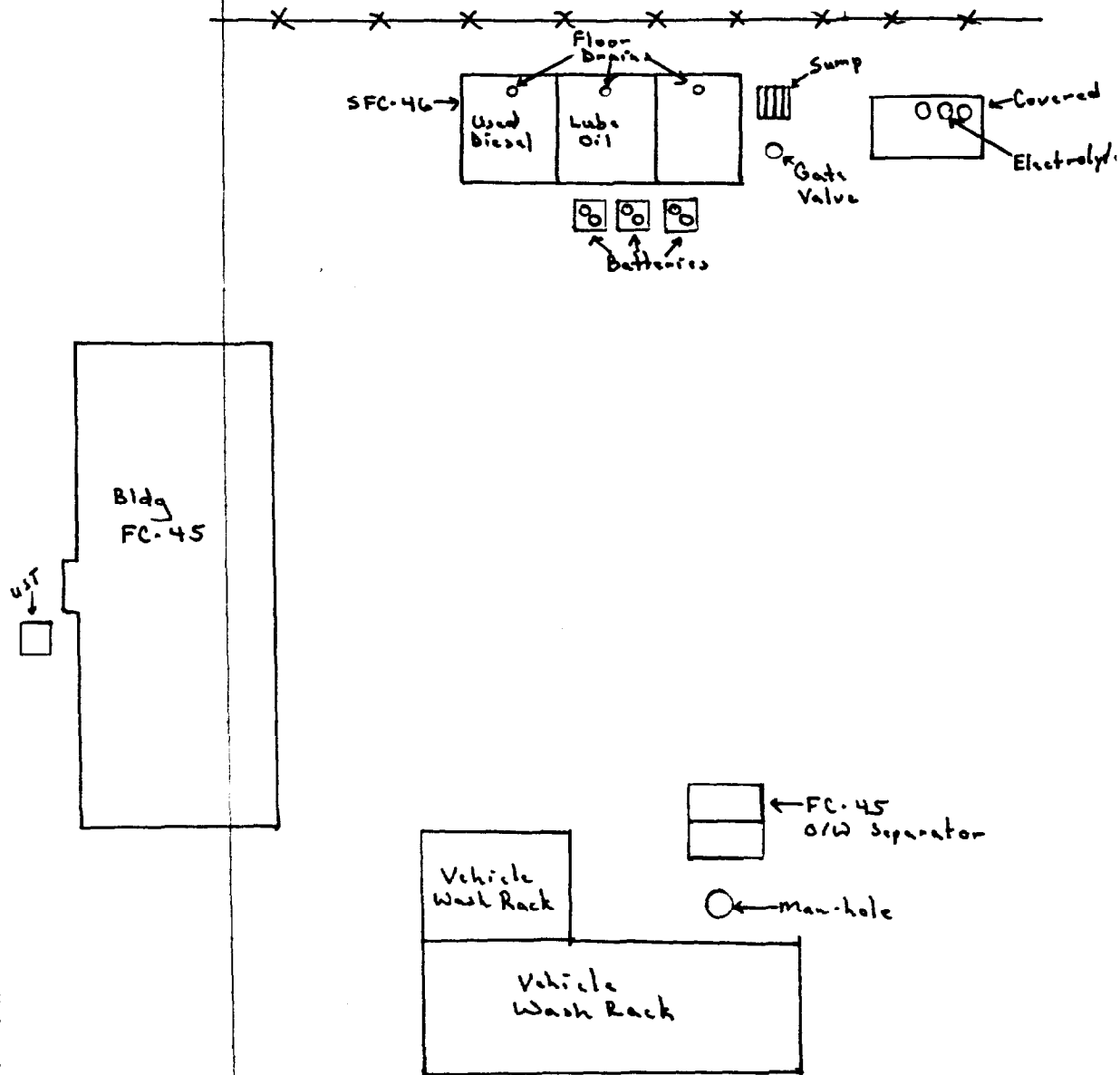



A11  
11-17-93  
1000

2d FSSG Electronics Maintenance Co.

Unknown (FC-51) - o/w Separator

Photo 22, Roll 1

Unknown (FC-51) - 490 H.W. Unit

Photo 22, Roll 1

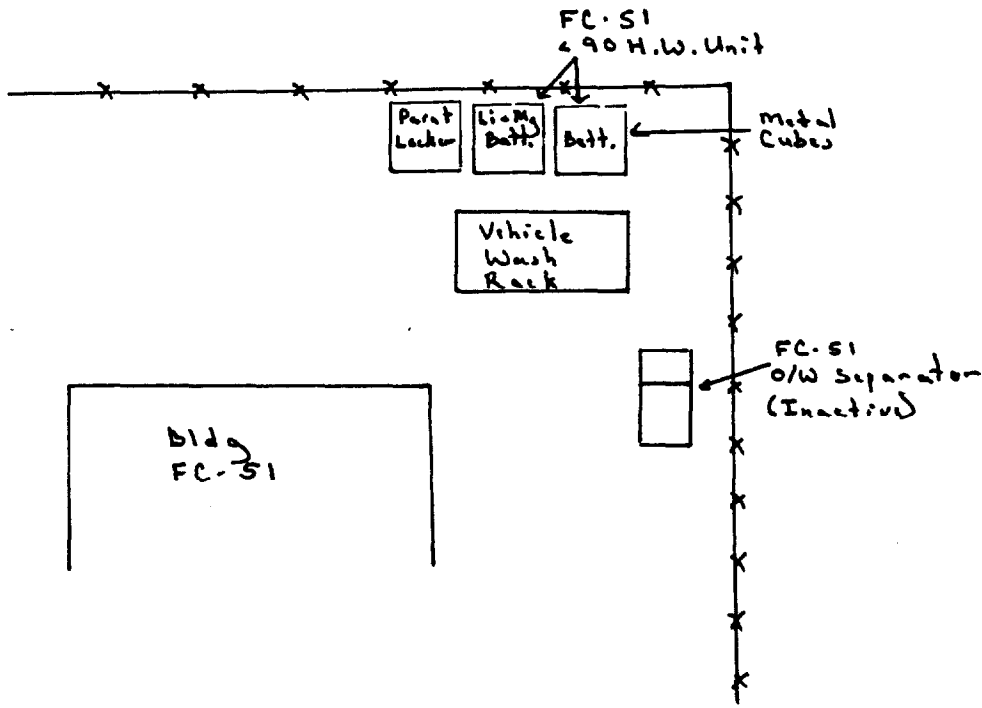

A12

11-17-93  
1030

2d FSSG Motor Transport Maintenance

1601 - < 90 H.W. Unit

Photo 23, Roll 1

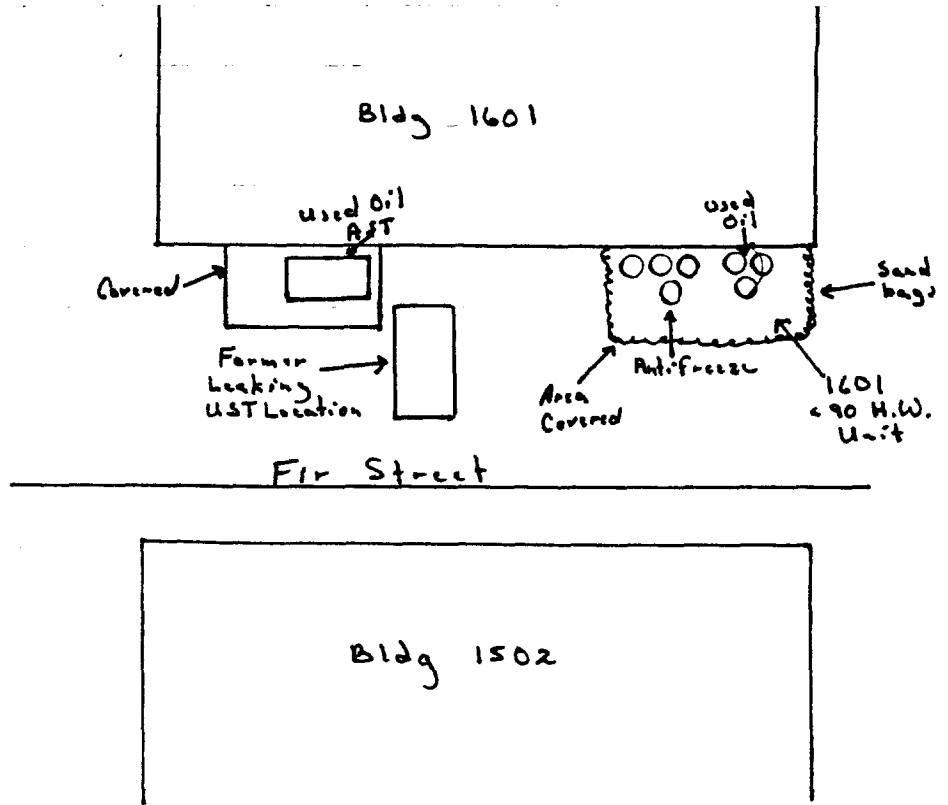

A13  
11-17-93  
1100

1st FSSG Engineer Maintenance Co.

902 - 90 H.W. Unit

Photo 24+25, Roll 1

902 - Used Oil AST

Photo 24, Roll 1

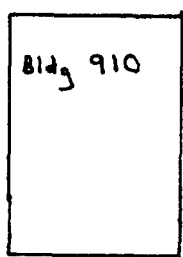
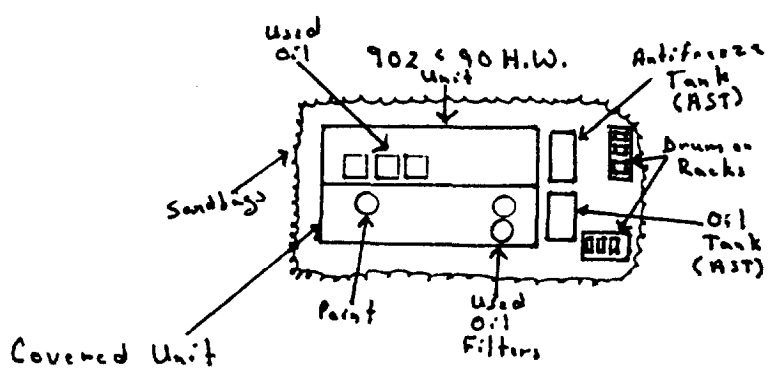
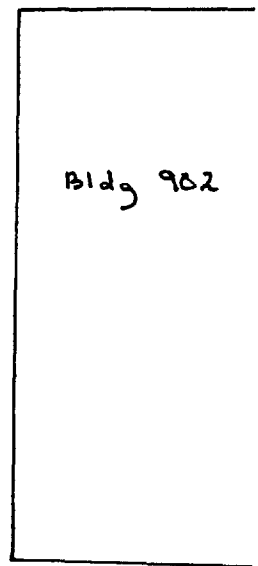

A14

11-17-93  
1120

2d FSSG 8<sup>th</sup> Engineers

816.1 - O/W Separator

816.2 - Grit Chamber

Photo 26+27, Roll 1

Photo 26+27, Roll 1

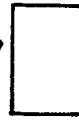
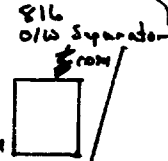
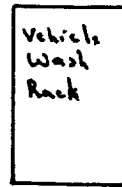
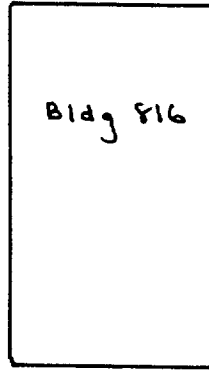

from  
from

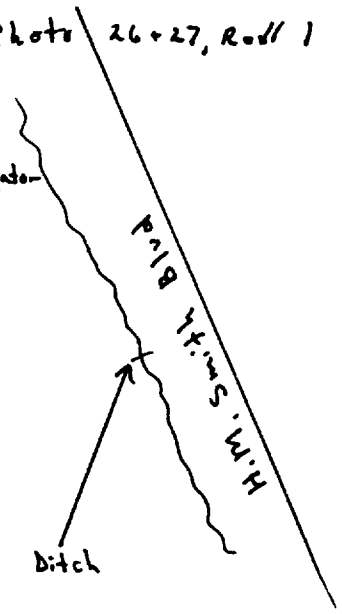

Both Units Flush  
with Ground

A 15  
11-17-93  
1145

2d FSSG 8th Engineers  
GP-19 - O/W Separator

Photo 28, Roll 1

H.M. Smith Blvd

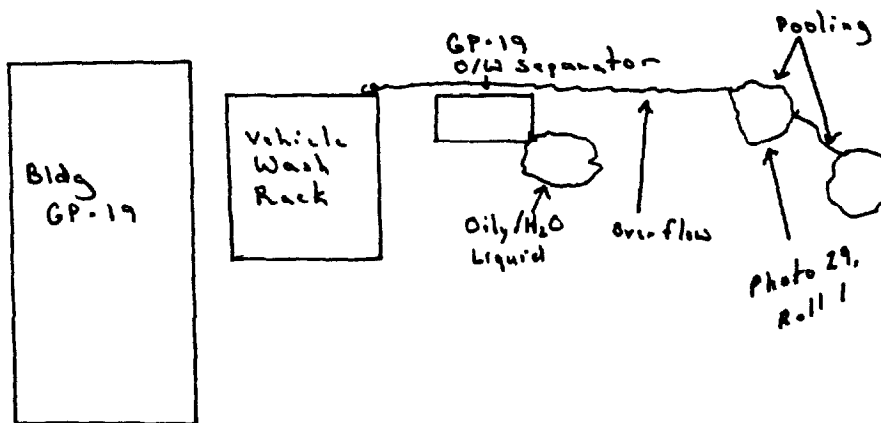

A 16

11-17-93  
1200

2d FSSG 8th Engineers

739-1 - O/W Separator

~~739-1~~ 739-2 - Grit Chamber

Photo 30, Roll 1

Photo 30, Roll 1

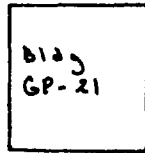

Main Service

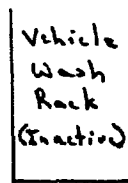
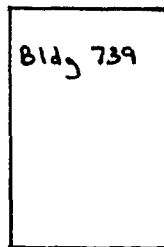

Grease  
station



739-2  
Grit  
Chamber



739-1  
O/W Separator

Both units believed Inactive

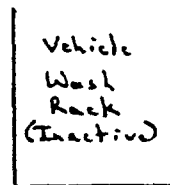

A 17  
11-17-93  
1300

2d FSSG 8th Engineers  
SFC-221 • 490 H.W. Unit  
Main Service

Photo 31, Roll 1

Bldg FC-200

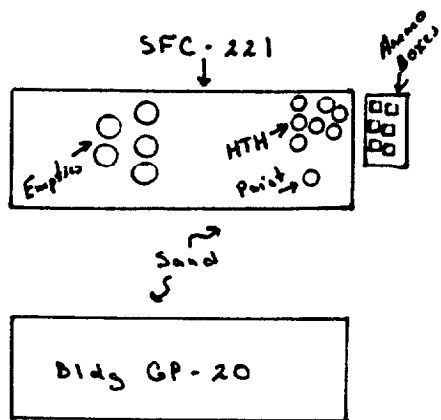

A18

11-17-93  
1330

2d FSSG 8th Engineers  
FC-200 - O/W Separator  
Main Service

Photo 32, Roll 1

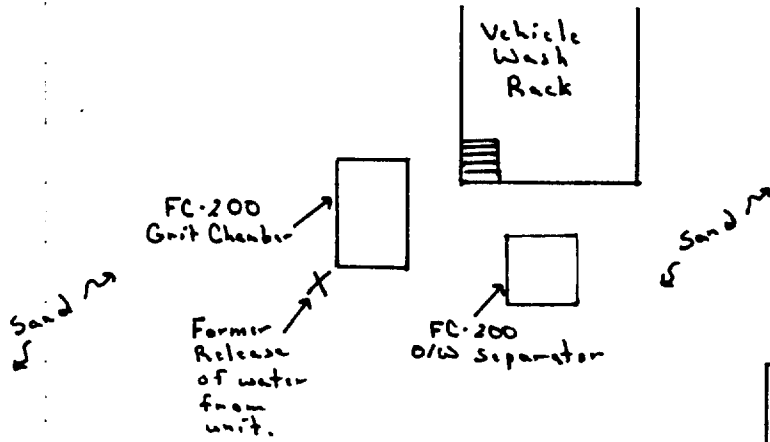
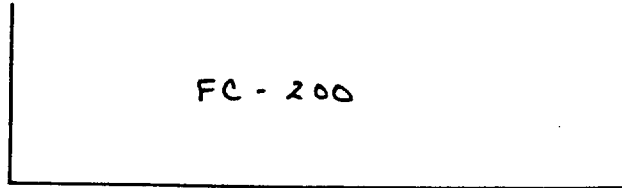



A19  
11-17-93  
1400

### 2d FSSG Landing Support Battalion

- FC-120 - O/W Separator Photo 34, Roll 1
- FC-120 - 490 H.W. Unit Photo 33, Roll 1
- SFC-145 - 490 H.W. Unit Photo 35, Roll 1

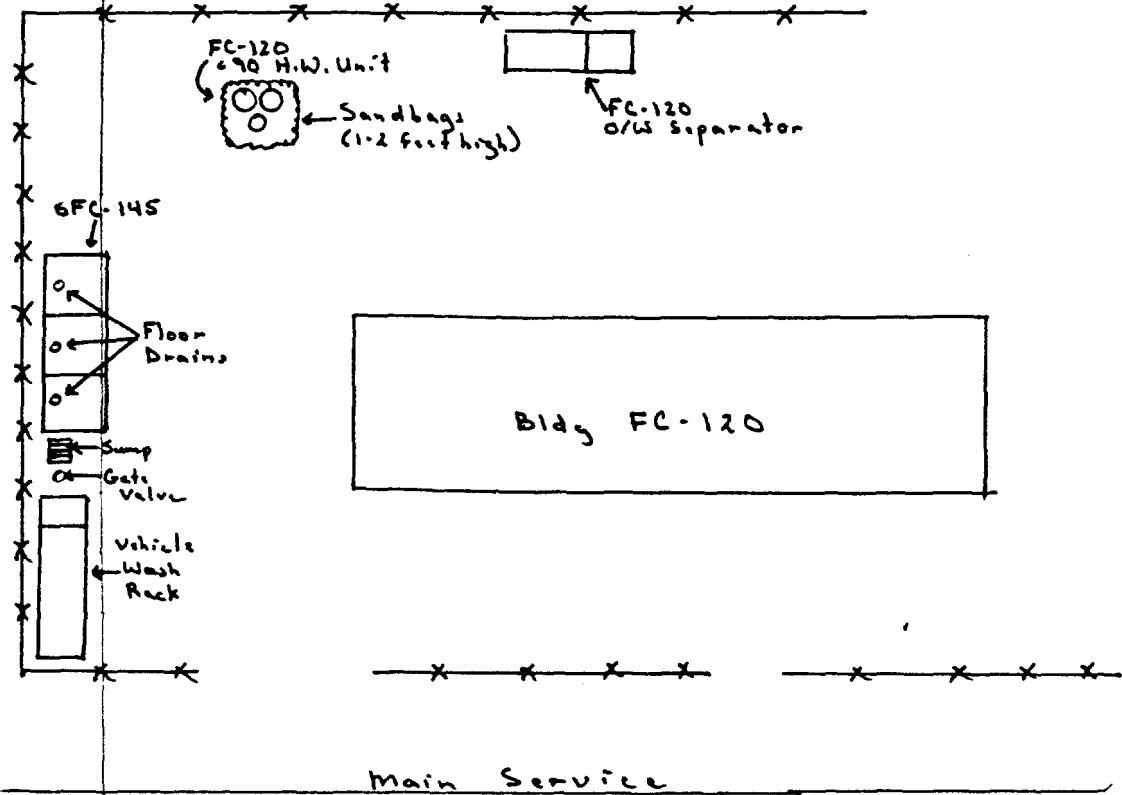

A 20

11-17-93  
1500

2d FSSG Landing Support Battalion

FC-134 - O/W Separator

Photo 36 , Roll 1

FC-134 - 490 H.W. Unit

Photo 37 , Roll 1

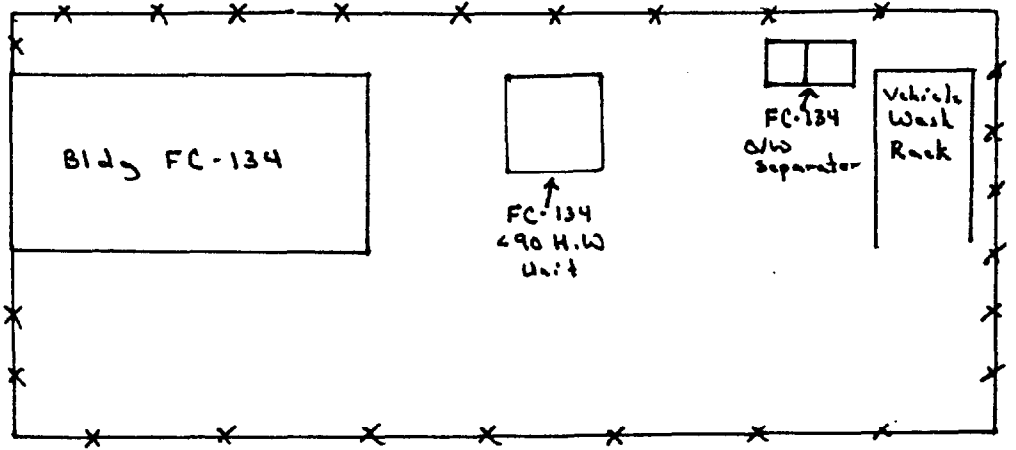

A 21  
11-17-93  
1600

2d FSSG 8th Motor Transport  
FC-270 - O/W Separator Photo 1, Roll 2

Vehicle  
Wash  
Rack

Bldg FC-270

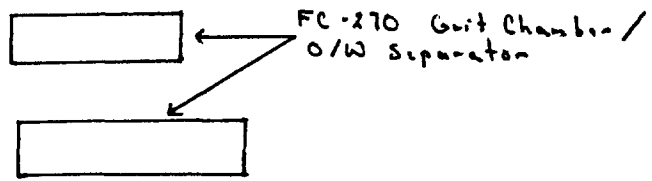
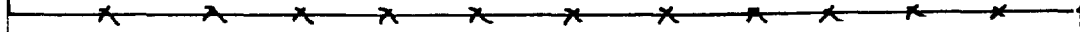

Main Service

A22

11-17-93  
1630

2d FSSG 8<sup>th</sup> Motor Transport

SFC-279 - < 90 H.W. Unit Photo 2, Roll 2

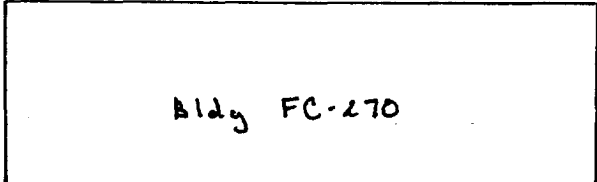
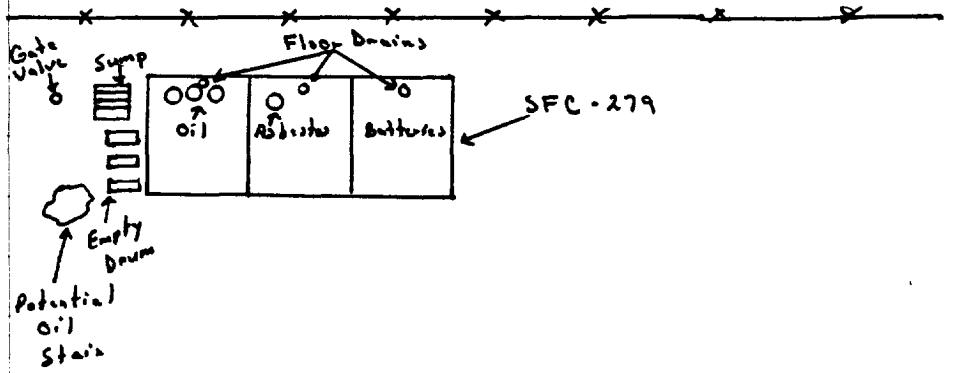

Main Service

A 23  
11-18-93  
0800

MESS Group

M 119 - O/W

SM-93 - 490 H.W. Unit

SM-91 - O/W Separator

Photo 2, Roll 6

Photo 1, Roll 2

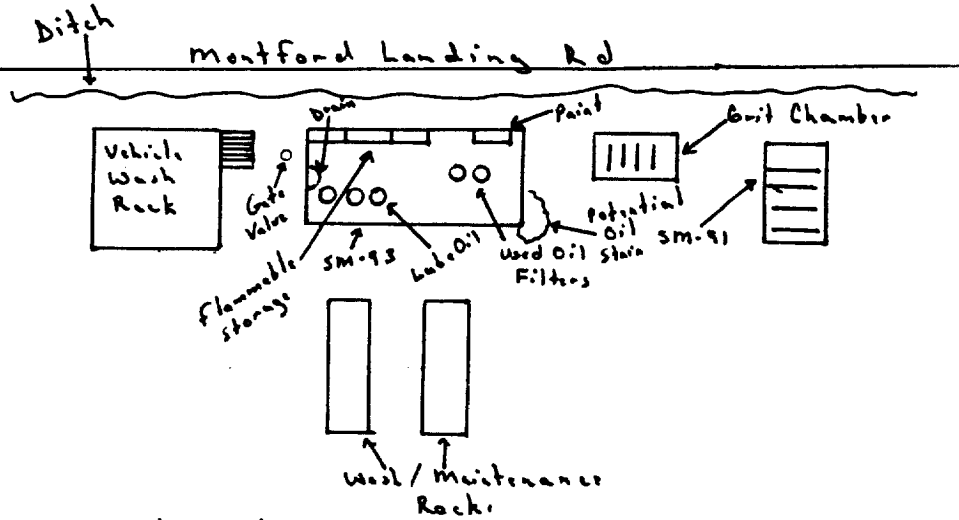

Gate valve believed  
to discharge to ditch.  
Unit is covered (SM-93)

A 24

11-18-93  
0830

MCSSS Group

M-144 - < 90 H.W. Unit

Photo 3, Roll 26

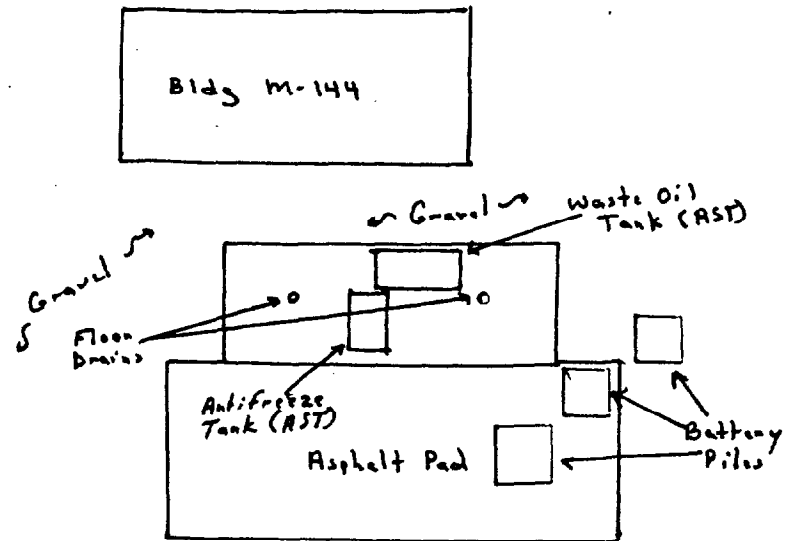

Floor Drain discharge unknown.

A 25  
11-18-93  
0845

MCSST Group  
M-90 - 490 H.W Unit

Photo 4, Roll 26<sup>com</sup>

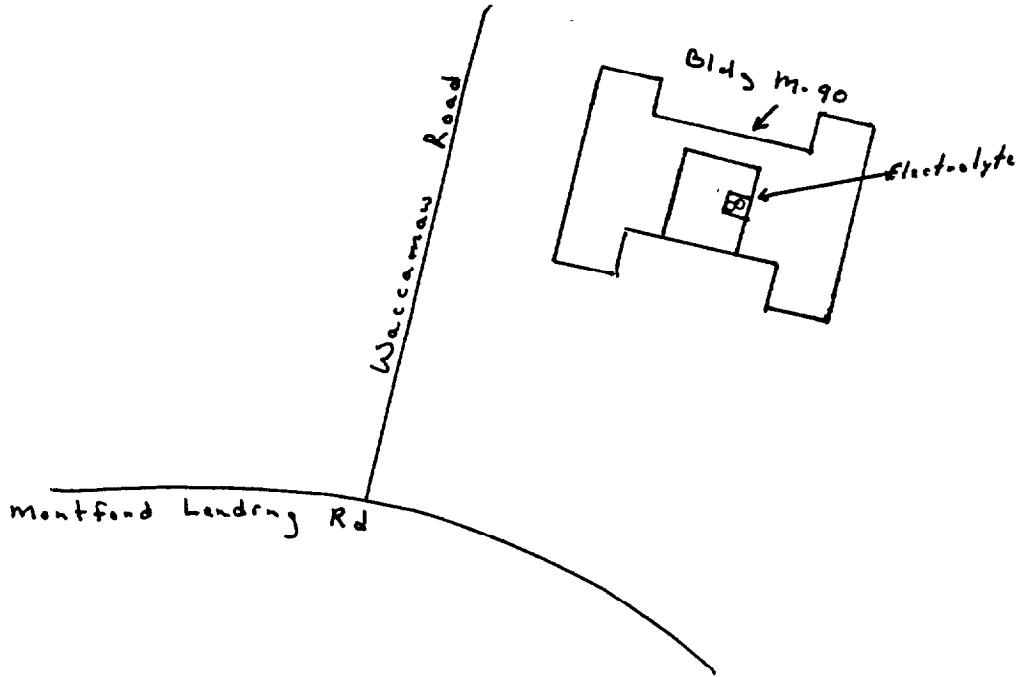

A26

11-18-93  
0900

MCSSS Group

SM-187 - O/W Separator

Photo 5, Roll 26

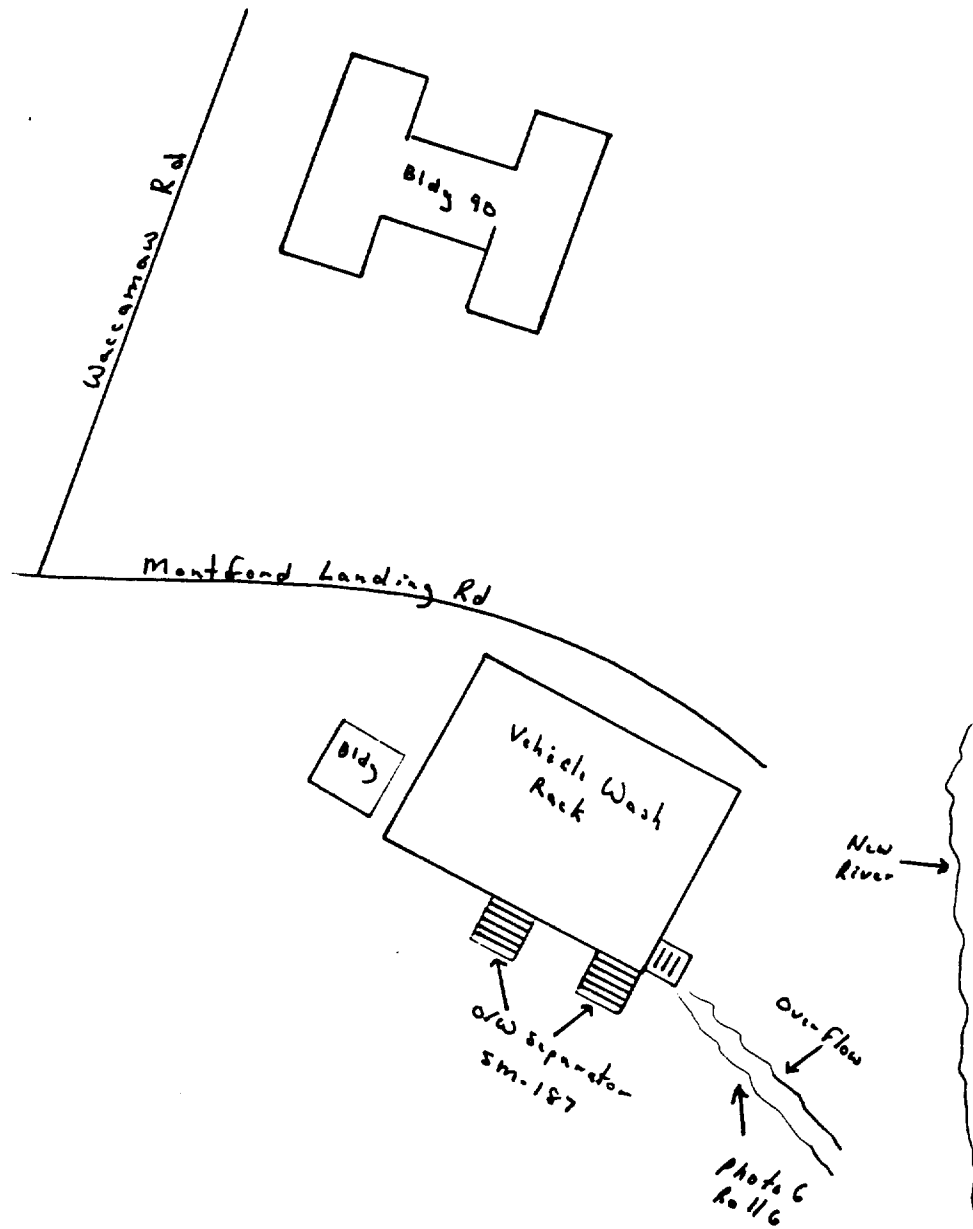



A 27  
11-18-93  
0950

2d Combat Engineer Battalion  
S1805 - 490 H.W. Unit  
S1859 - O/W Separator

Photo 7, Roll 26  
Photo 849, Roll 26

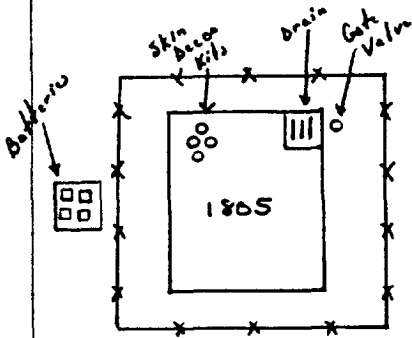

Unit is covered & bermed

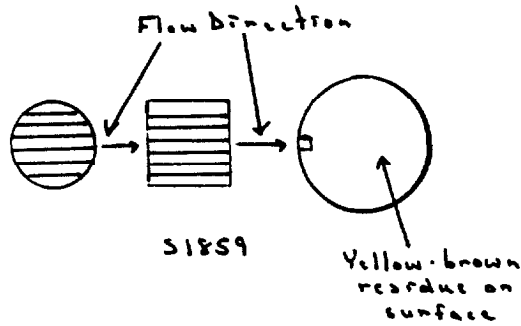

3021 Sp10

A28

11-18-73  
0945

2d Combat Engineer Battalion

1895.1 - 490 H.W. Unit (Mg Batteries) Photo 10, Roll 26<sup>10</sup>

1895.2 - 490 H.W. Unit (Li Batteries) Photo 11, Roll 26

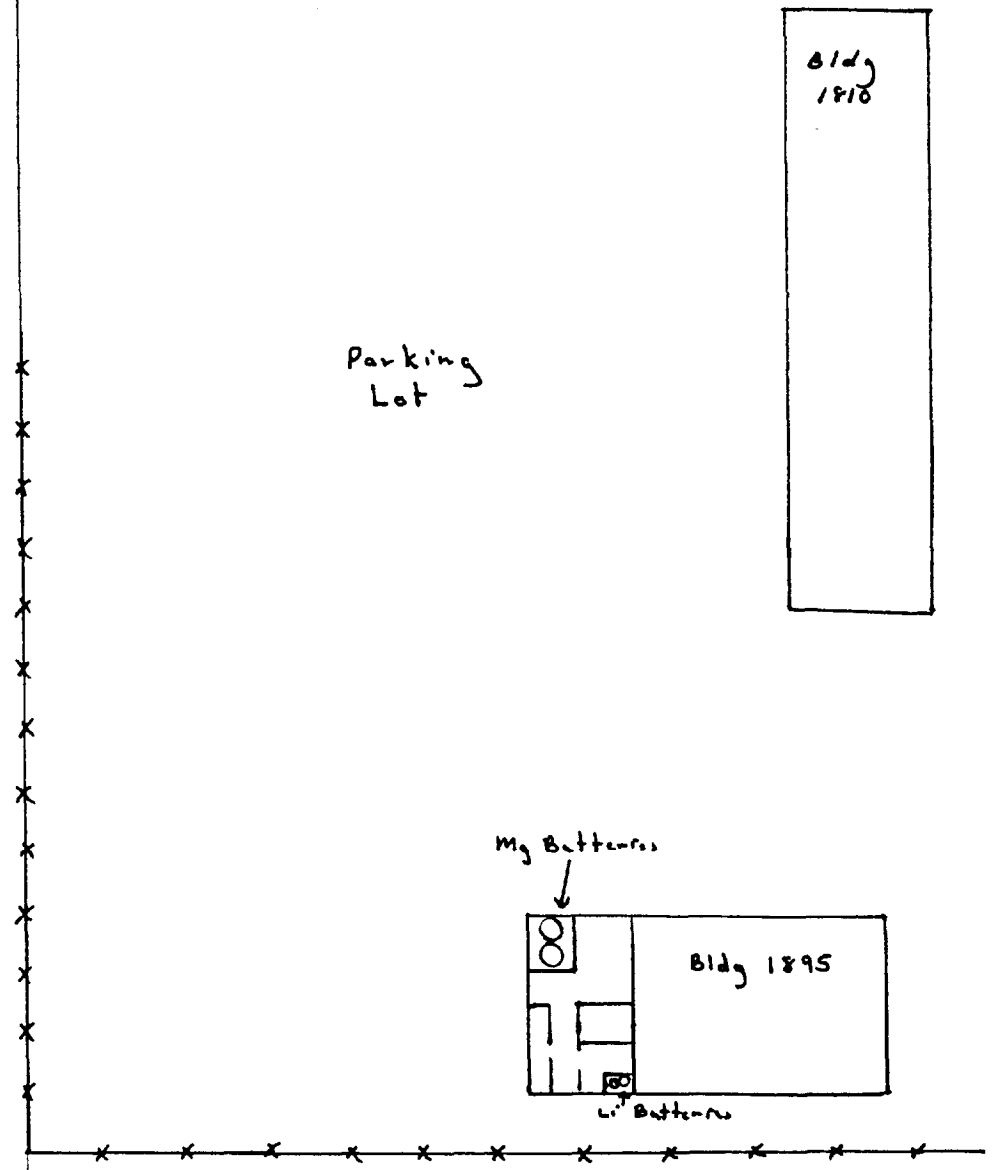

Brig Company

1041 - 490 H.W. Unit

A 29  
11-18-93  
1000

Photo 12, Roll 2  
CAM 6

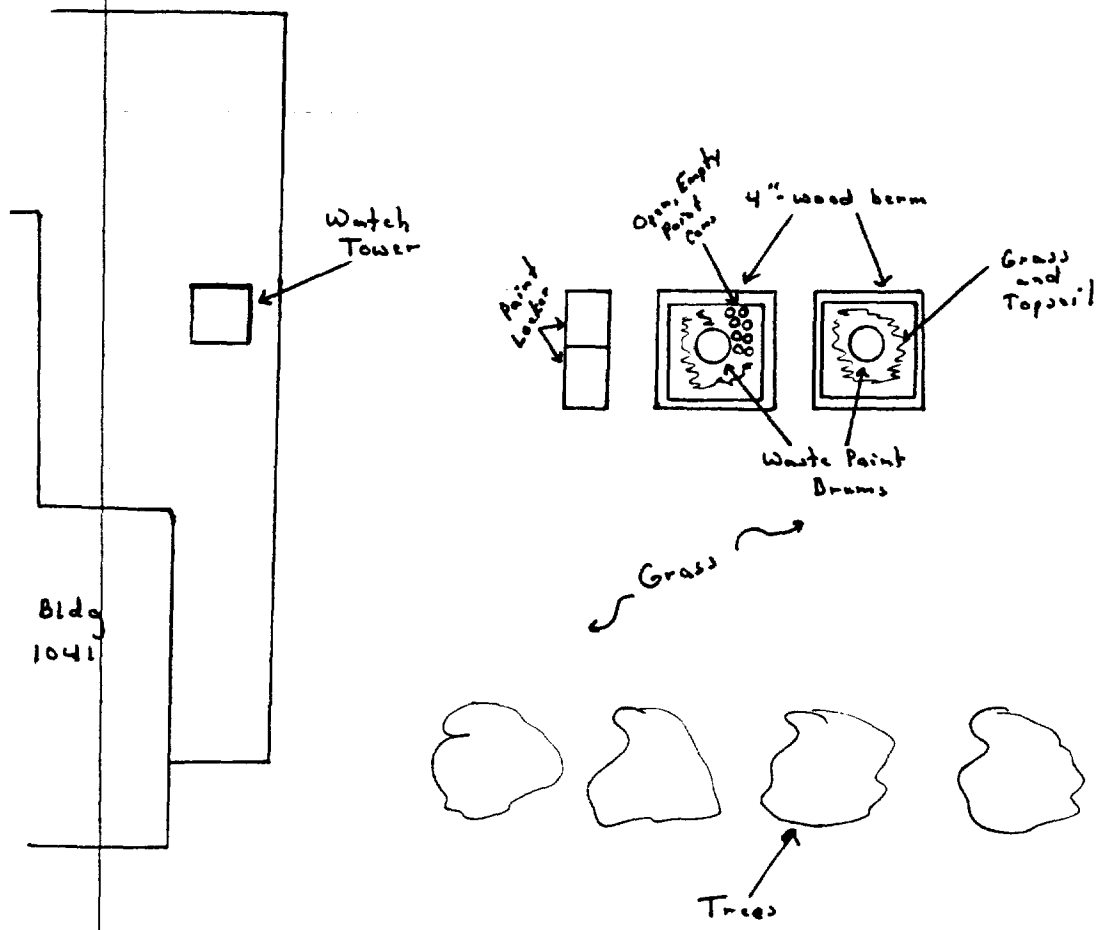

A 30

11-22-93  
0700  
~~11-22-93~~  
CA 70 1100

Base Maintenance  
1203 - O/W Separator

Photo B, Roll 2

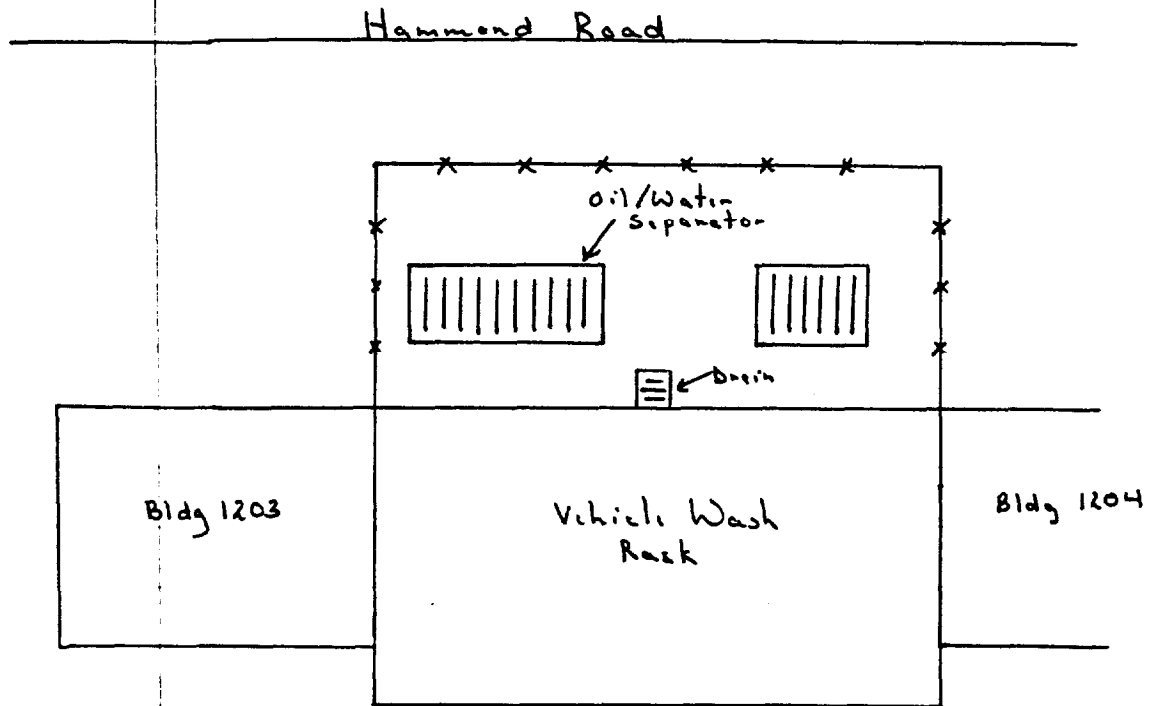

A31  
18-22-93  
0930

Base Maintenance  
1105 (1133) - O/W Separator

Photo A, Roll 2

Hammond Road

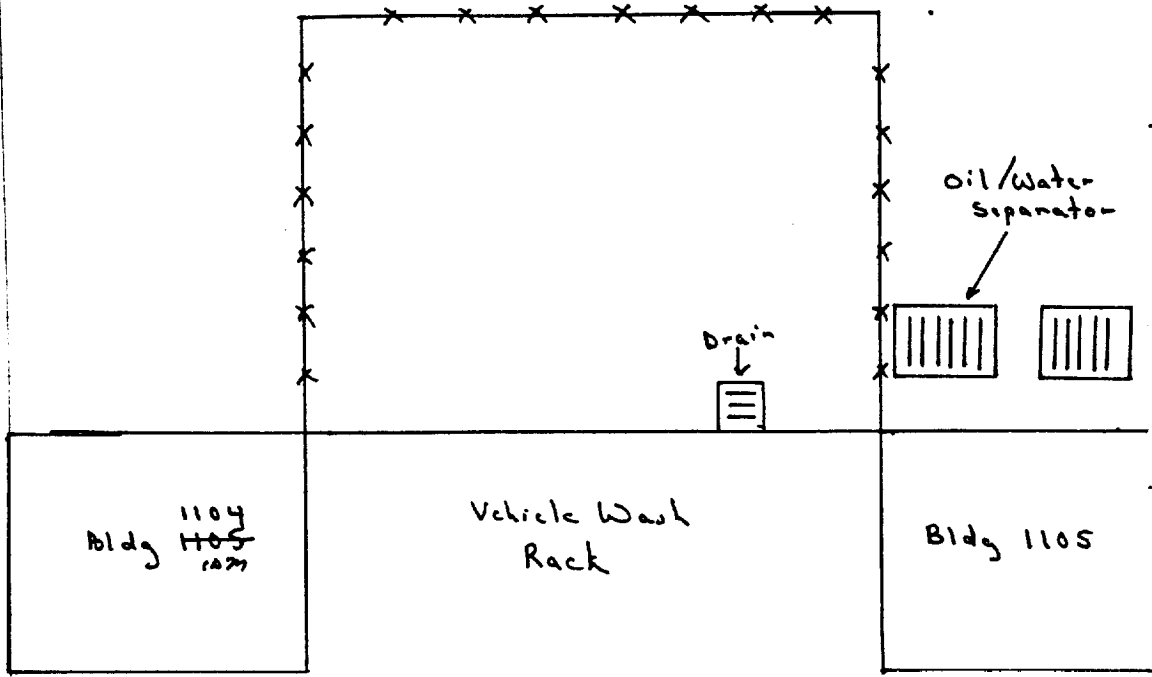

Curb ↗

A 32

11-22-93  
0900

Base Maintenance

S1131 - 4 90 H.W. Unit

Photo <sup>5</sup>15, Roll 12

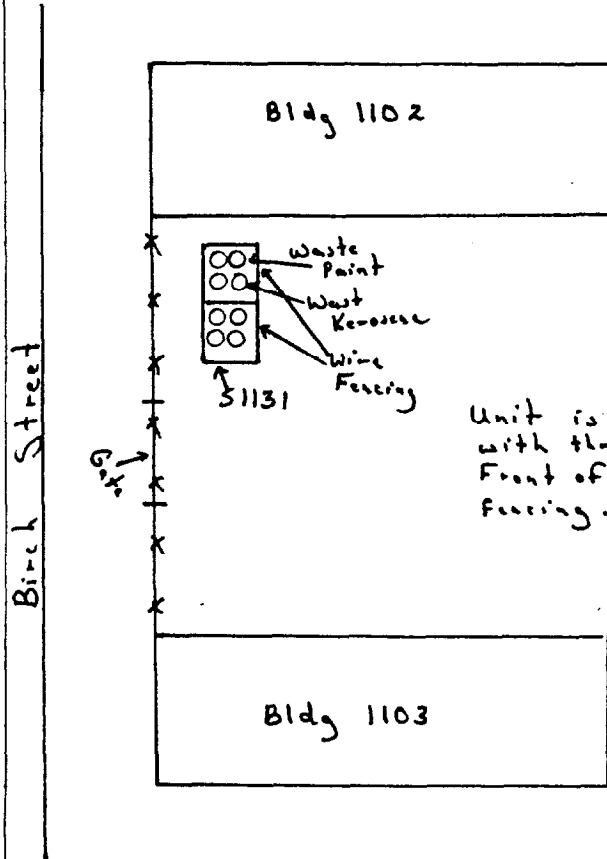

Unit is covered with three full walls. Front of unit is wire feeding. Unit is diked.

A 33  
11-22-93  
0930

### Base Maintenance (Steam Plant)

1700-1 - O/W Separator

1700-2 - O/W Separator

Photo ~~16~~<sup>6</sup>, Roll 2

Photo ~~17~~<sup>7</sup>, Roll 2

Coal Settling  
Pond  
(Runoff from coal  
pits)

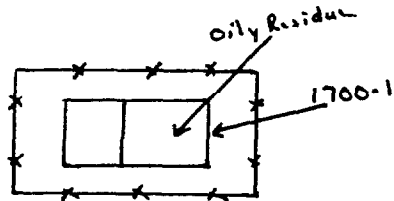

Retaining  
Wall  
( $\approx 3'$ )

Coal  
Pile



Bldg 1700



Appeared to have  
dumped heavy  
substance into  
O/W Separator

1700-2

Gate

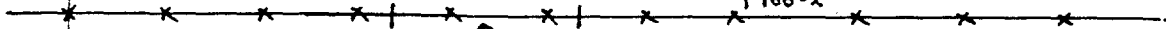

A 34

11-22-93  
1600

Base Maintenance  
(S-1698)  
S-1735 - O/W Separator

Photo 79, Roll 2

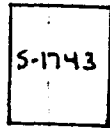
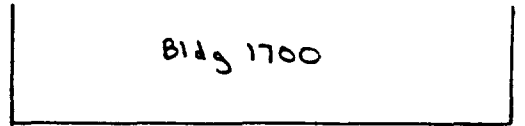

Coal  
Landing

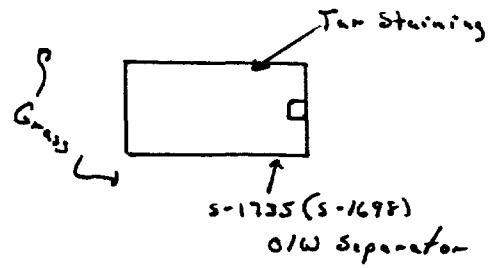



A-35  
11-22-93  
1020

Base Maintenance  
738 - O/W Separator

Photo ~~20~~<sup>10</sup>, Roll 2

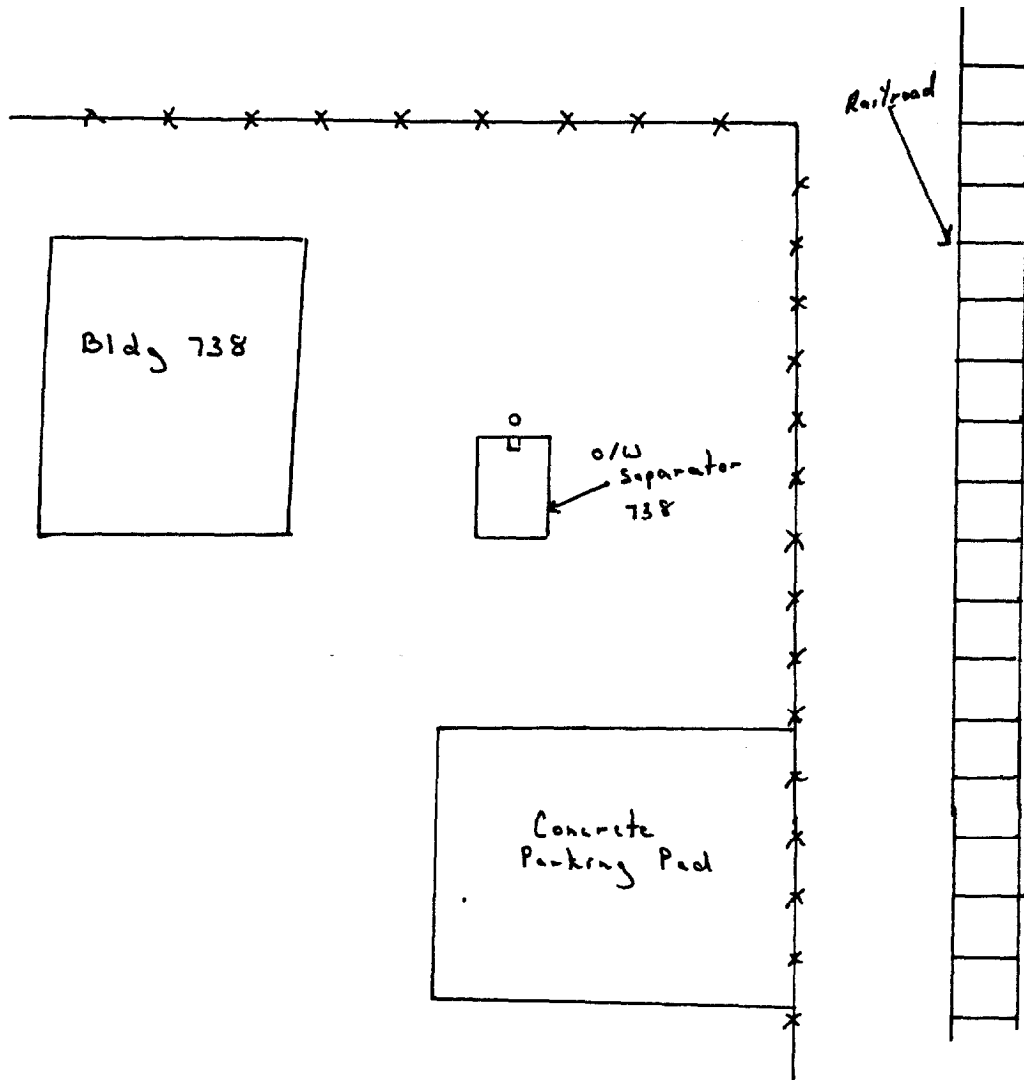

A 36

11-21-93  
1040

Base Maintenance

45 - 490 H.W. Unit

Photo <sup>11</sup> 24, Roll 2

5792 - O/W Separator

Photo <sup>13</sup> 23, Roll 2

SLCH 785 - Spill Containment Basin

Photo 12, Roll 2

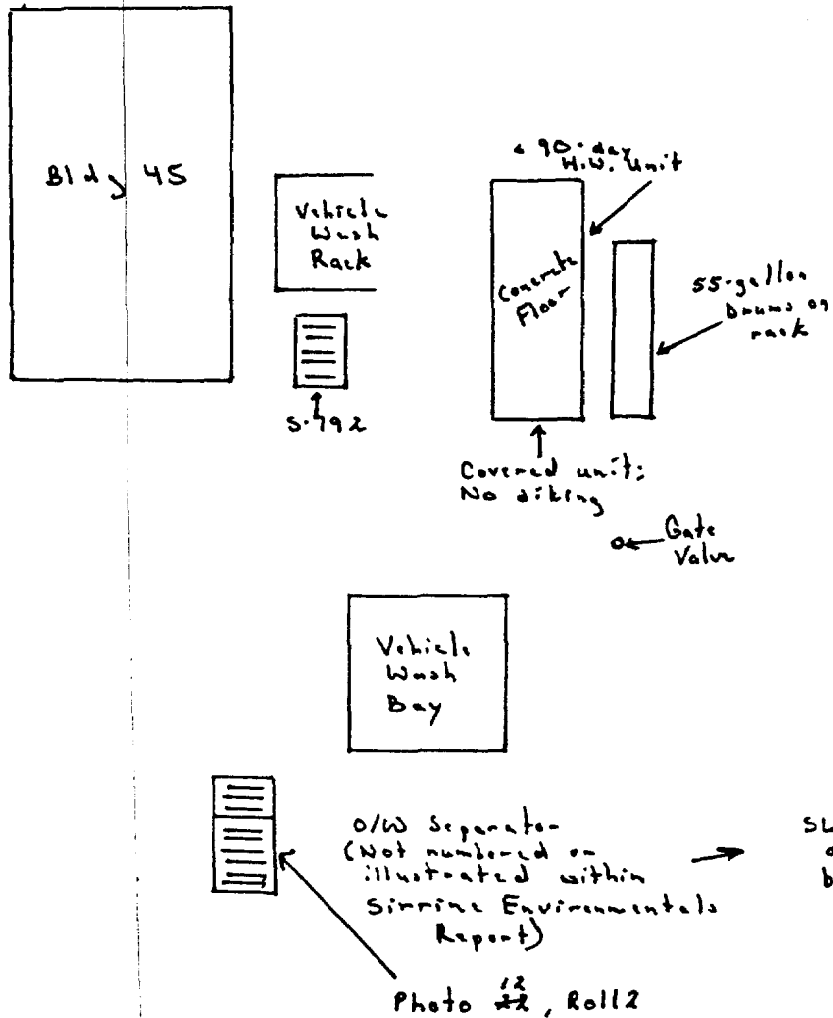

437

11-22-93  
1300

Training and Support Division  
1403 - 490 H.W. Unit

Photo 15, Roll 2  
com

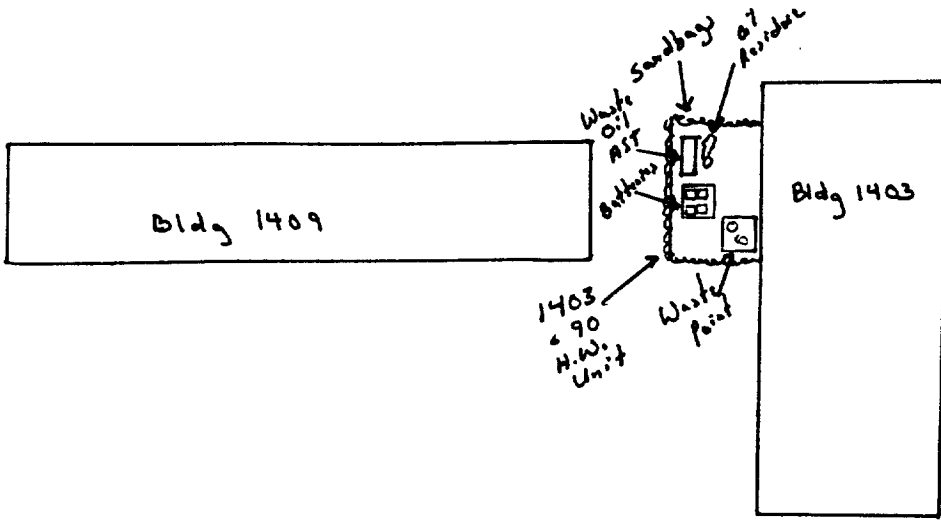

Parking Lot

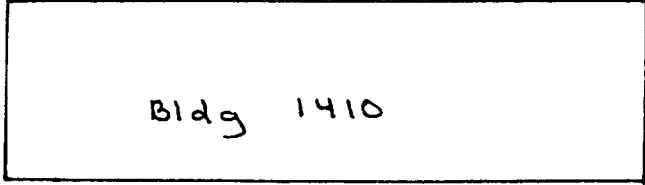

East Road

Dogwood Street

A 38

11-22-93  
1330

Morale, Welfare and Recreation

S1762 - 490 H.W. Unit

Photo #6, Roll 2

Football  
Field

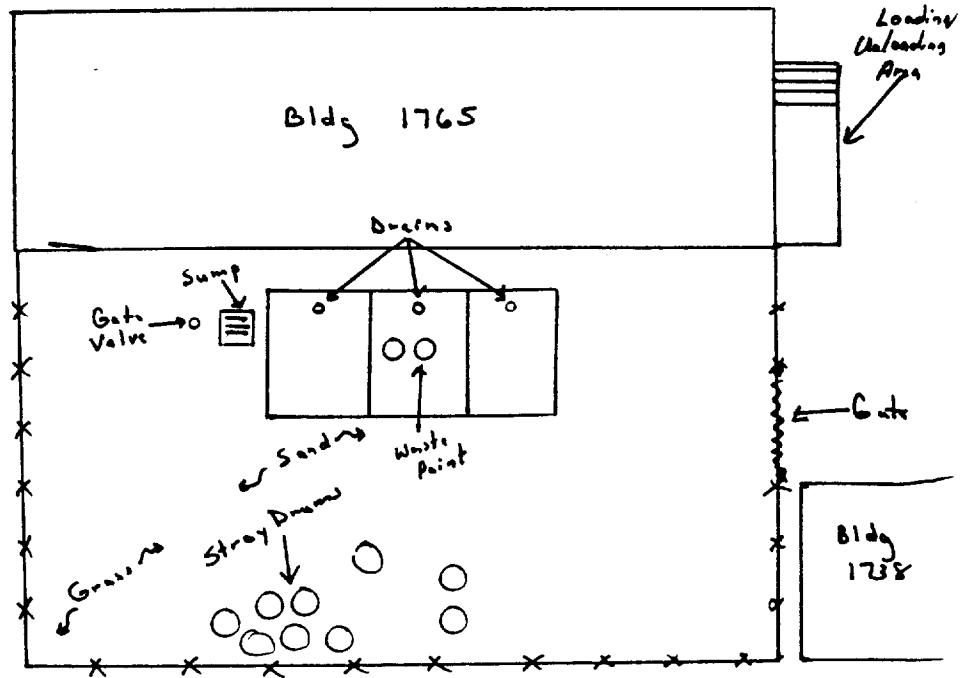

A 39  
11-22-93  
1400

School of Infantry

TC-773 - O/W Separator

Photo ~~27~~<sup>17</sup>, Roll 2

TC-773 - 490 H.W. Unit

Photo ~~28~~<sup>18</sup>, Roll 2

"G" Street

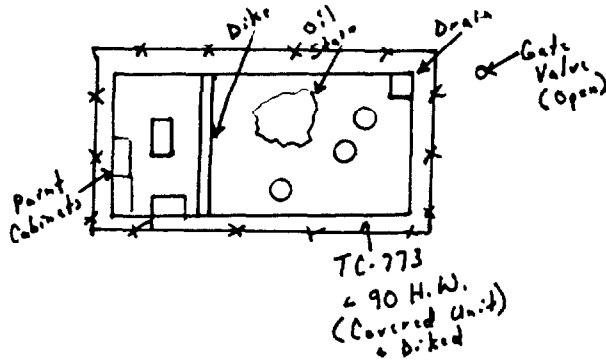
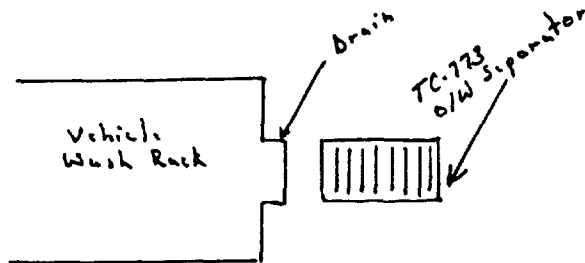
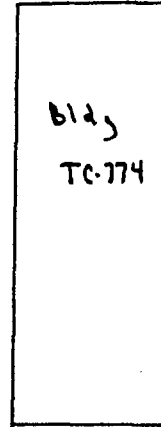

A40

11-22-93  
1415

School of Infantry  
STC-774<sup>RAM</sup> - o/w Separator

Photo 29<sup>13</sup>, Roll 2

"G" street

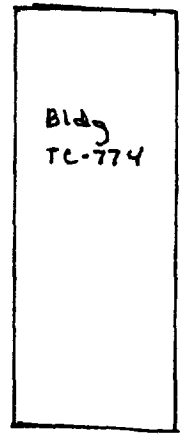
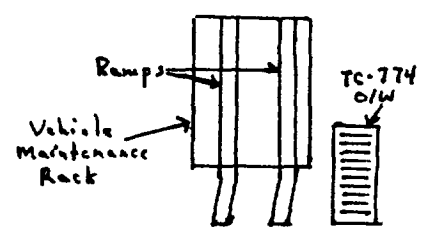
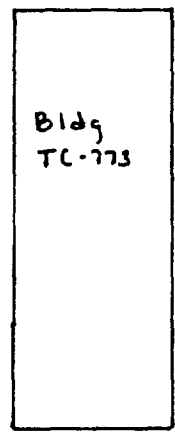

May be  
STC 777

A41  
11-22-93  
1430

Base Maintenance  
G-649 - O/W Separator

Photo 20421  
~~30421~~, Roll 2

"F" Street

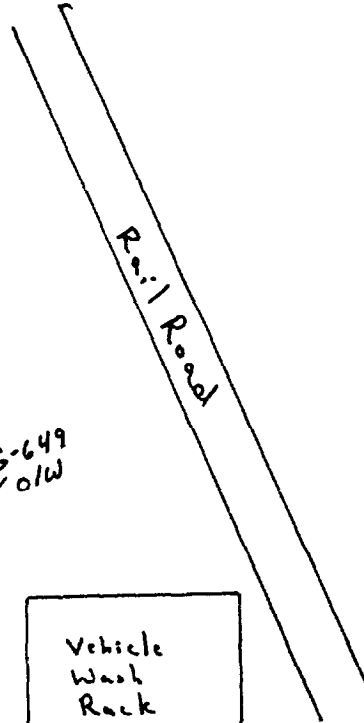
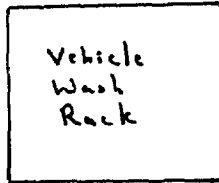
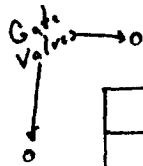
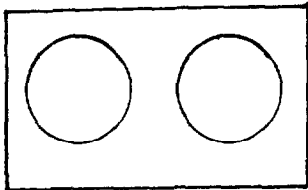
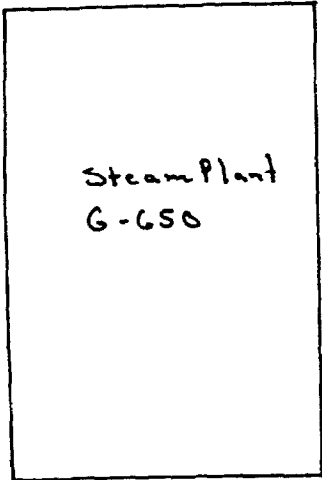

A42

11-22-93  
1495

Marine Corps Air Station  
SAS-137 - O/W Separator  
C029 Spill Containment Basin

Photo 24, Roll 2  
34

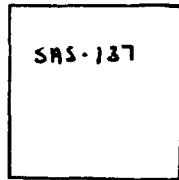
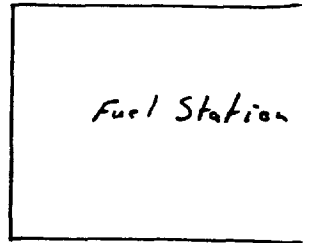

Gate Valve

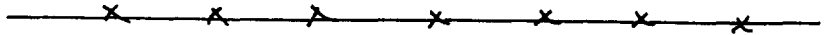

Campbell Road



A43

11-22-93  
1530

Base Maintenance  
M628 - O/W Separator

Photo <sup>25</sup> 35, Roll 2

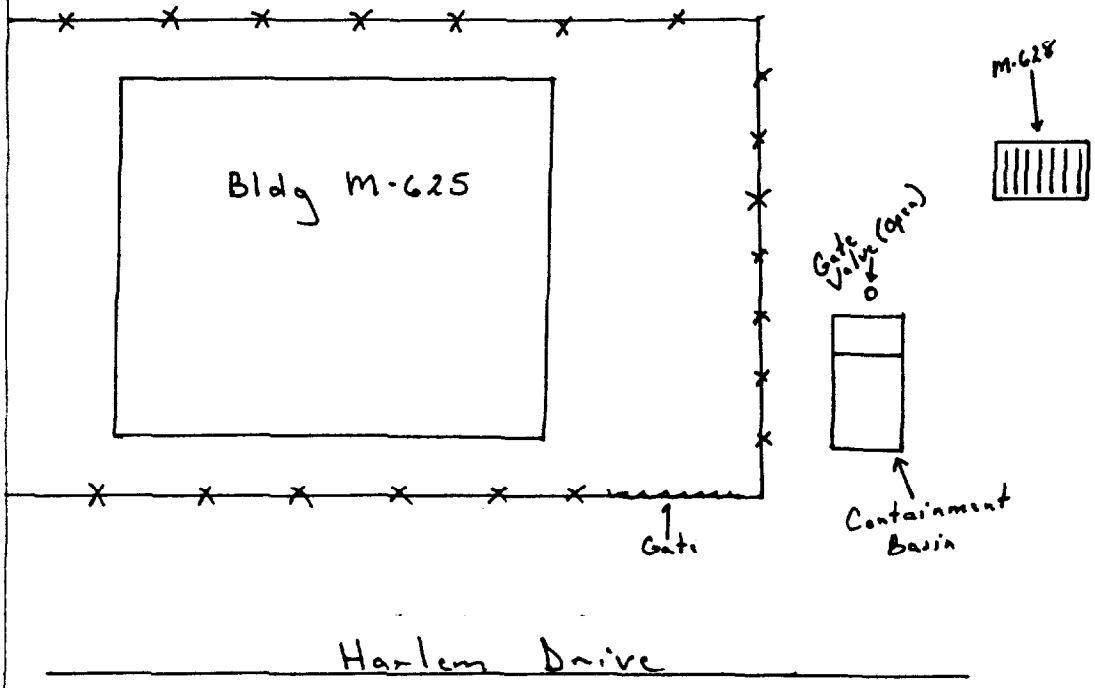

A44

11-23-93  
0900

Rifle Range

RR 62 - 490 H.W. Unit Photo <sup>26</sup>/<sub>36</sub>, R. 11 2

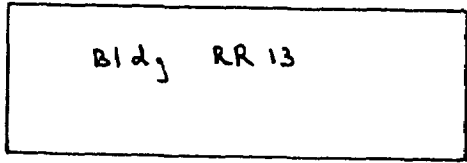
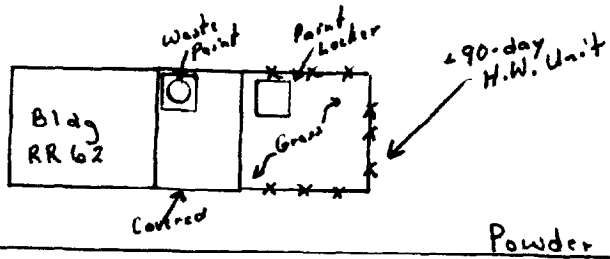

A45

11-23-92  
0930

Rifle Range

SRR-80 - O/W Separator

Photo <sup>27</sup> 37, Roll 2

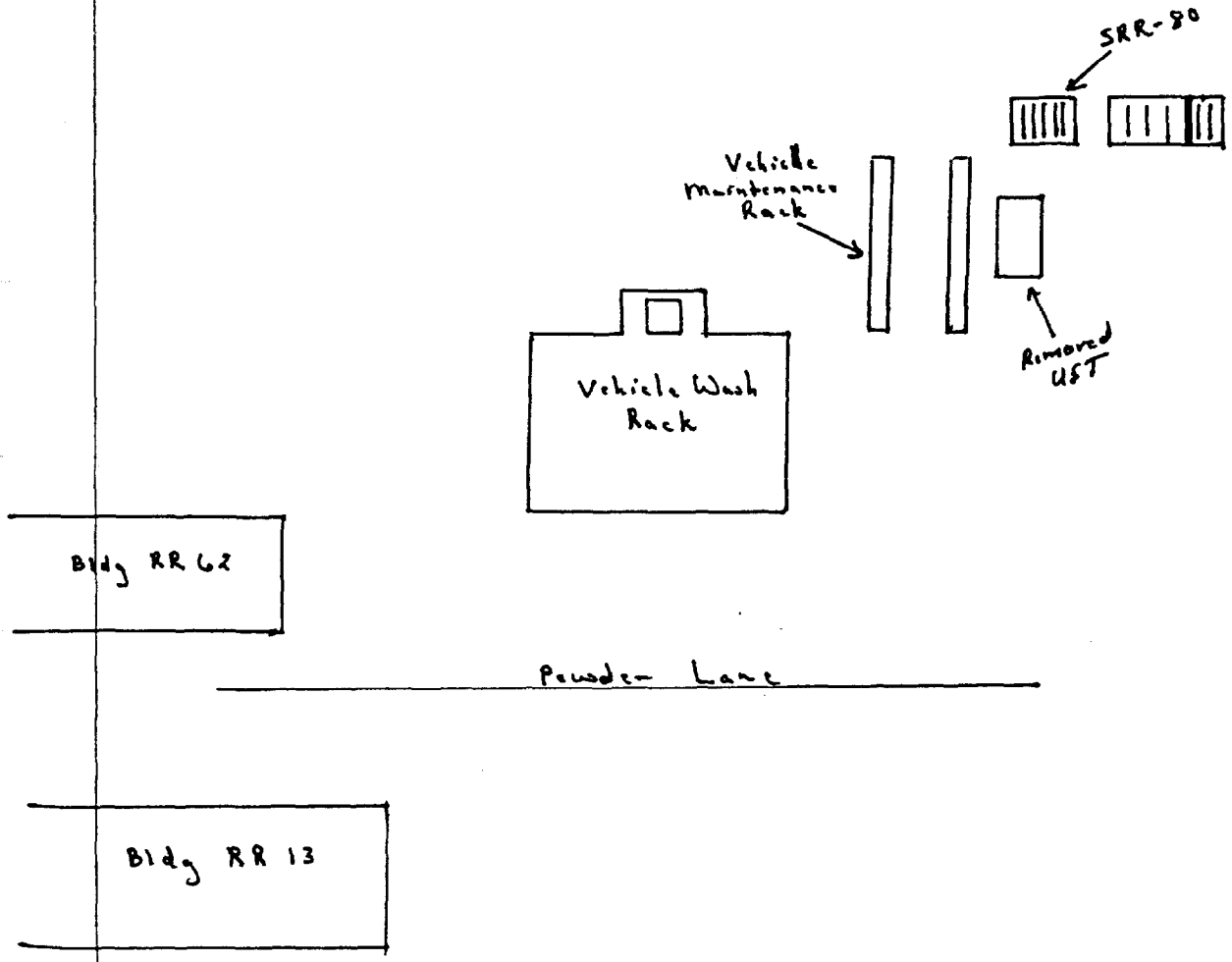

A46

11-28-93  
0900

Rifle Range

RR-15-1 - O/W Separator

Photo ~~34~~<sup>28</sup>, Roll 2

RR-15-2 - O/W Separator

Photo ~~34~~<sup>29</sup>, Roll 2

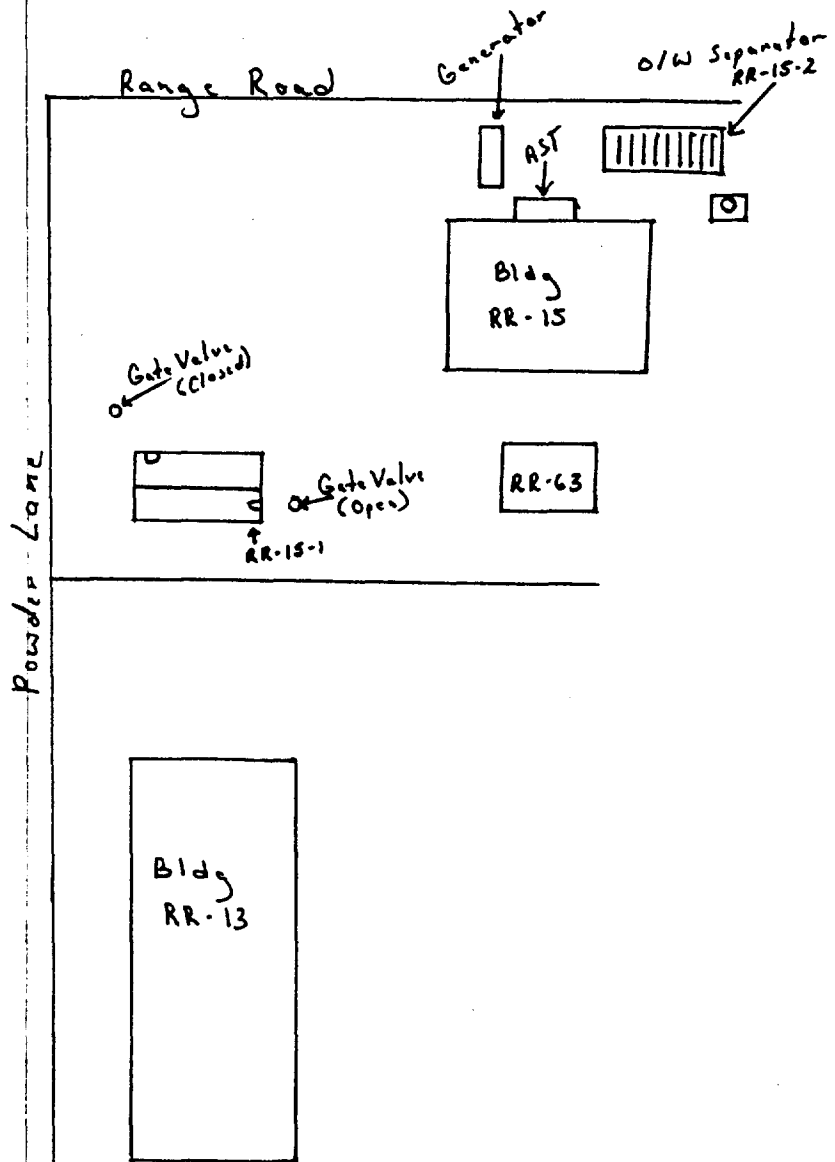

A 47  
11-23-93  
~~1000~~ 1300  
CO 2nd

Field Medical Services

M-178 - 6 90 H.W. Unit

Photo <sup>30</sup>/<sub>40</sub>, Roll 2

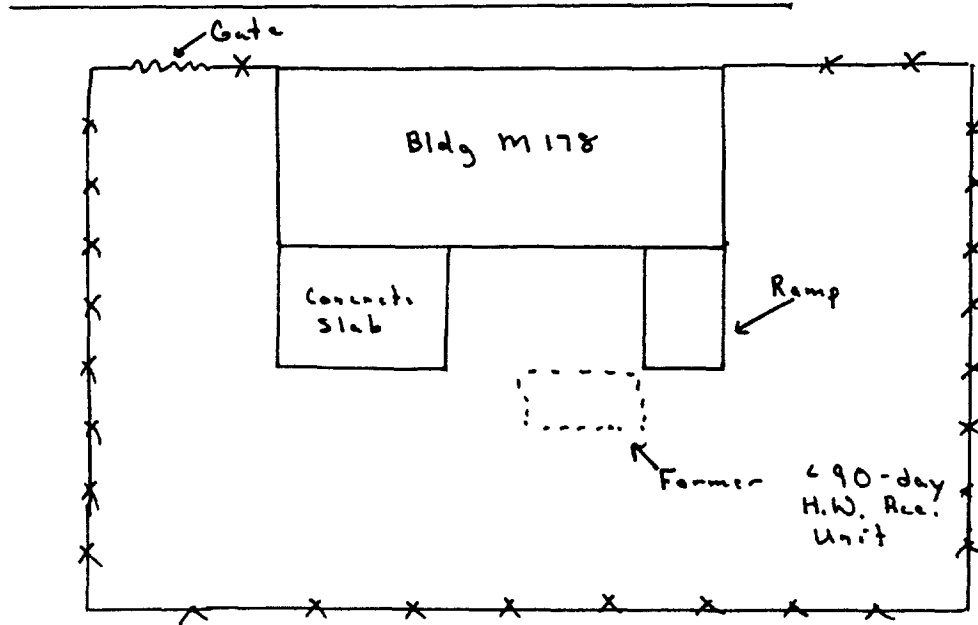

A4B

12-6-93  
0430

2d SRIG 8<sup>th</sup> Communication Battalion  
FC-230-1 - O/W Separator

Photo, Roll

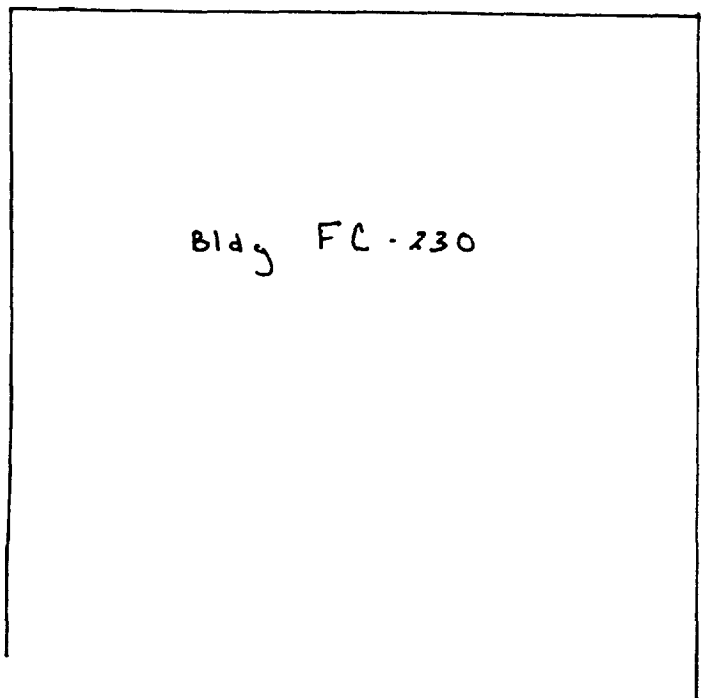
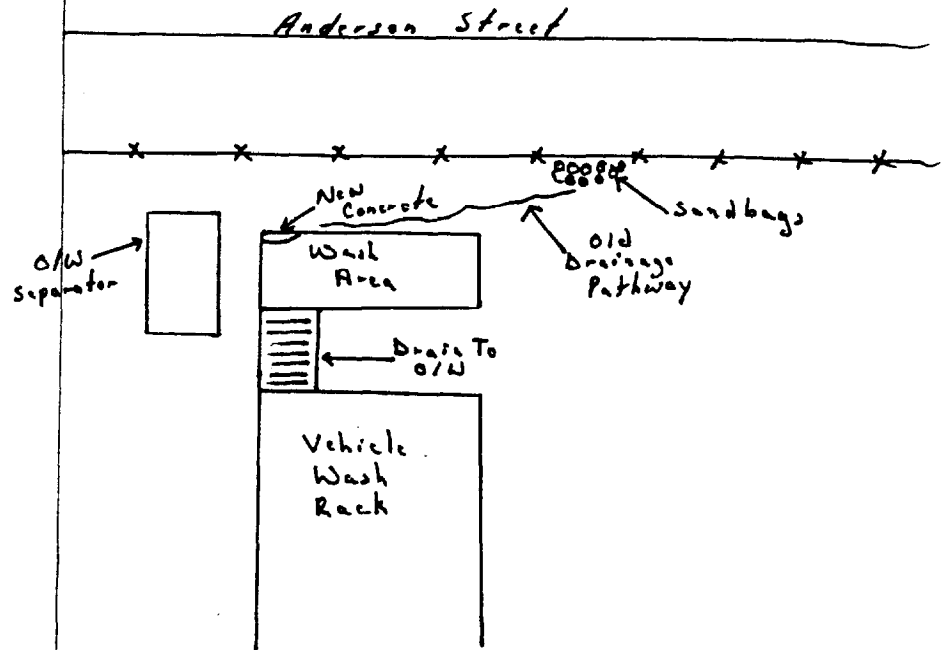

A 49  
12-6-93  
0245

2d SRIG 8th Communication Battalion

FC-230-2 - Oil/W Separator

Photo 2, Roll 3

SFC-235 - 490 HW Unit

Photo 3, Roll 3

Main Service

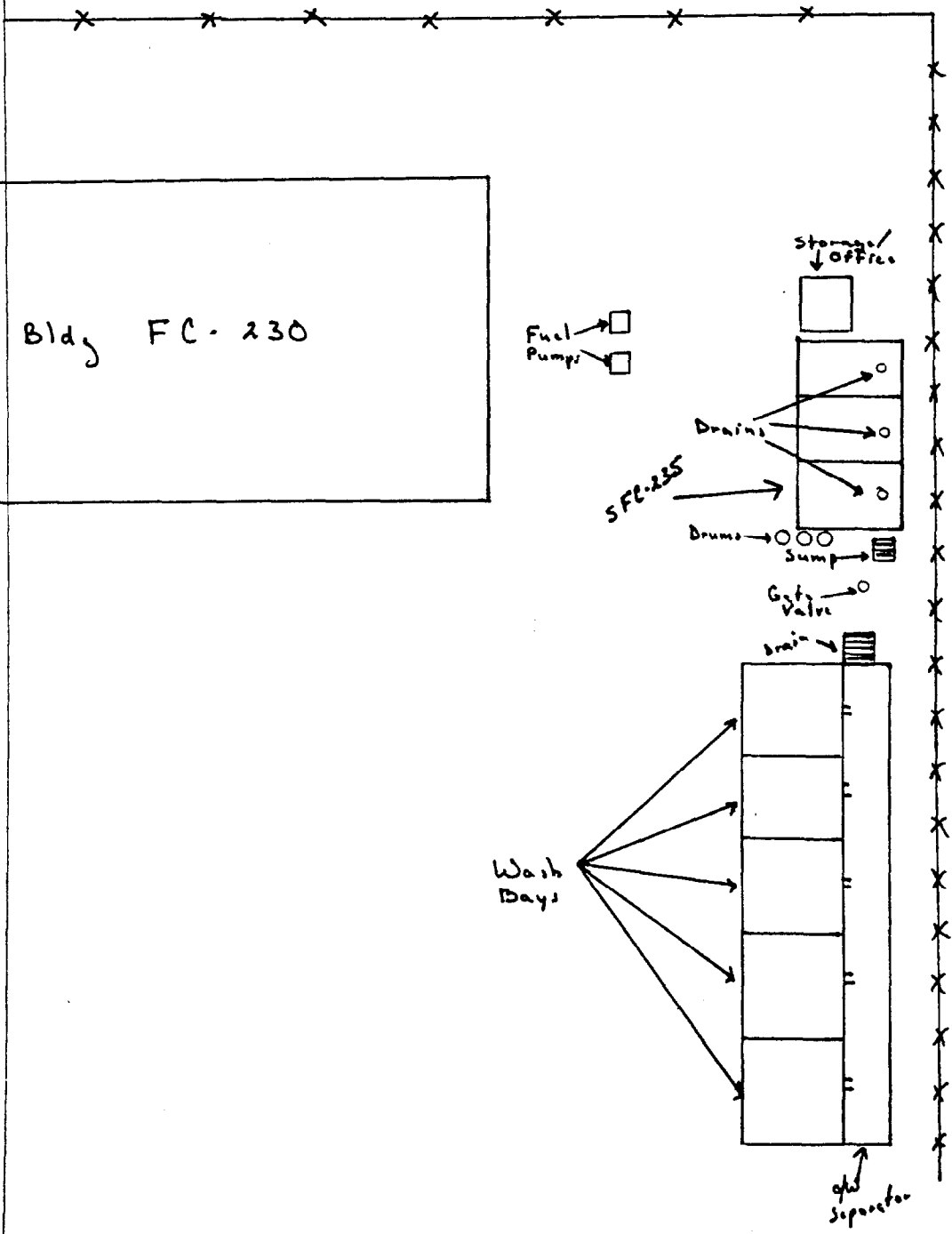

Bldg FC-230

Fuel Pumps

Storage/Office

Drains

SFC-235

Drums

Sump

Gate Valve

Drain

Wash Days

Oil Separator





AS1  
12-6-93  
1000

2d SRIG HQ and Service Co. (II MEF)

1771 - < 90 H.W. Unit

Photo 8, Roll 3

Trees

Parking Lot  
(Asphalt)

Antifreeze Batteries  
Electrolyte Containers  
Used Oil  
AST  
Bumper  
Sandbags (2)

< 90 Unit  
1771

Flammable  
Solvents

Bldg. 1771

Gum Street

Louis Road

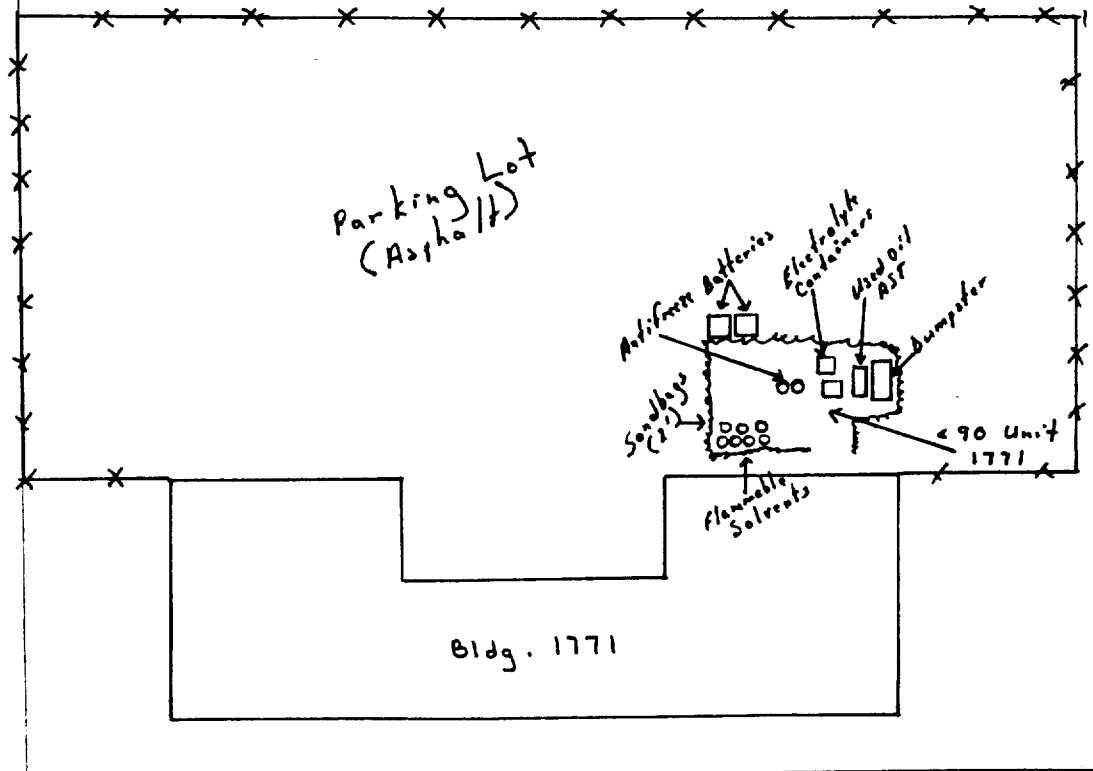

A52

12-6-93  
1045

1d SRIG 2d Anglico  
FC-251 - O/W Separator

Photo 10 , R.113

SFC237 - 490 H.W. Unit

Photo 9 , R.113

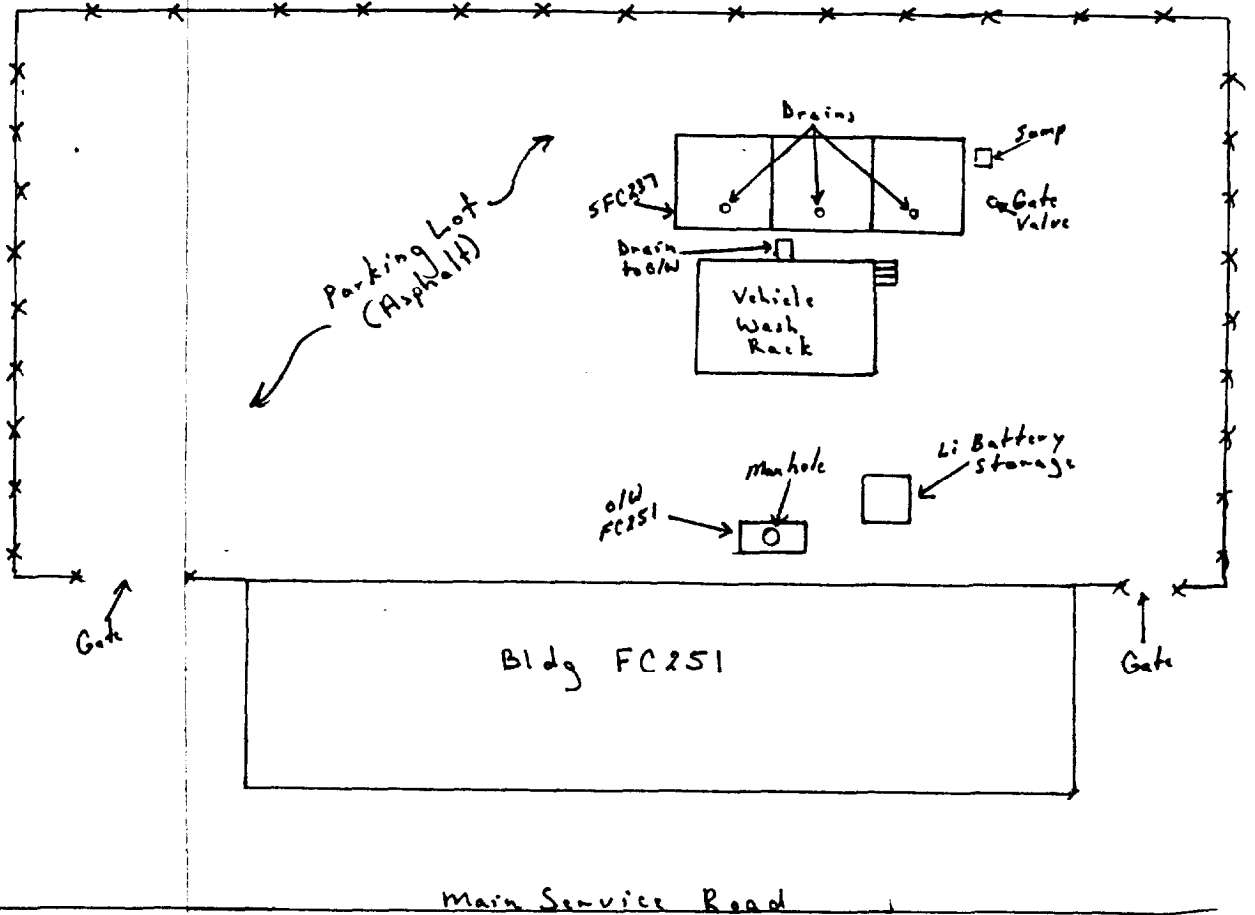

AS3

12-6-93  
1130

2d SRIG 2d Unmanned Aerial Vehicle

1747-1 - O/W Separator

Photo 11, Roll 3

1747-2 - O/W Separator

Photo 12, Roll 3

51746 - 490 H.W. Unit

Photo 16, Roll 3

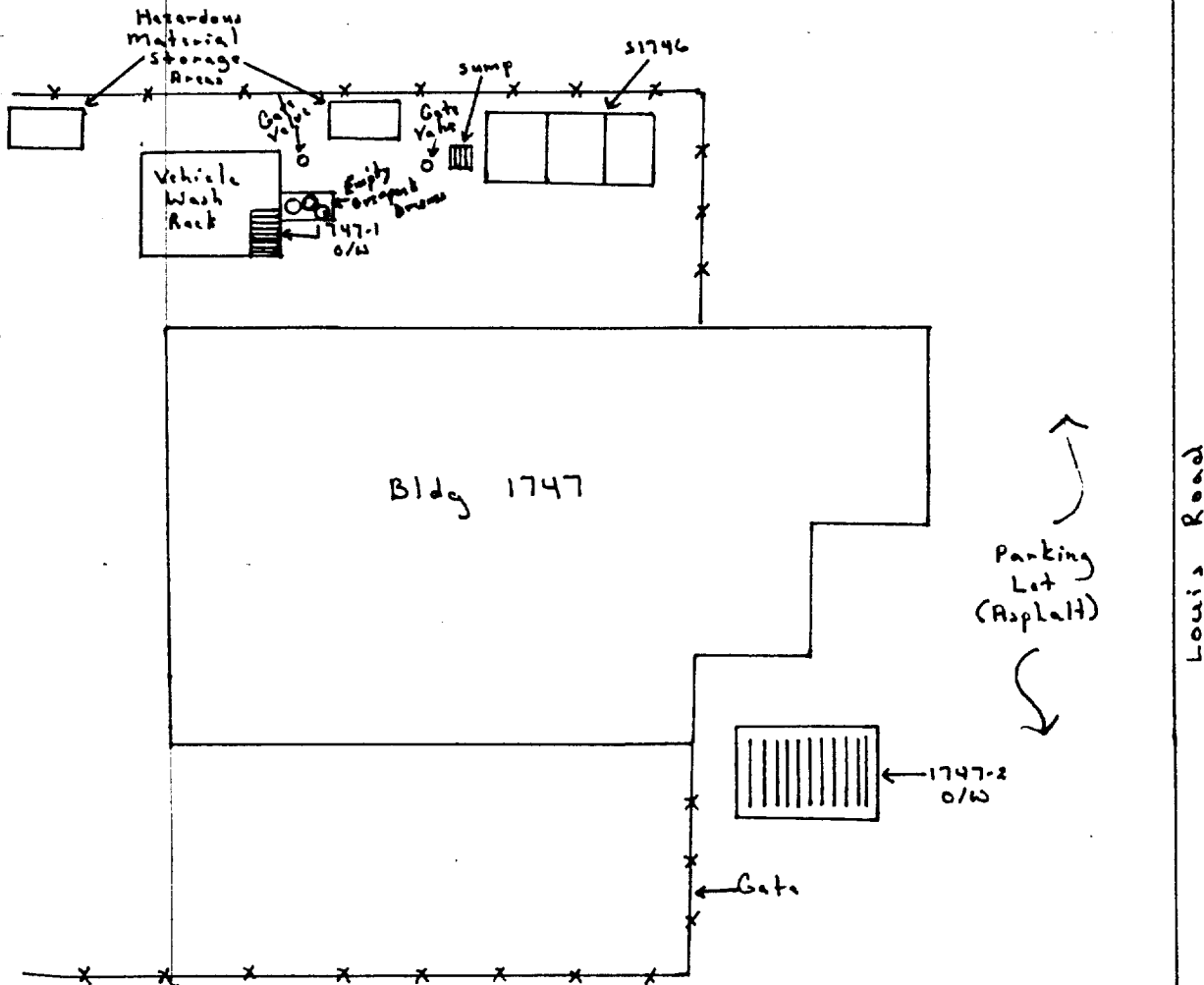

A 54

12-6-78  
1345

2d SREG 2d Radio Battalion

FC-365 - 490 H.W. Unit

Photo 13, Roll 3

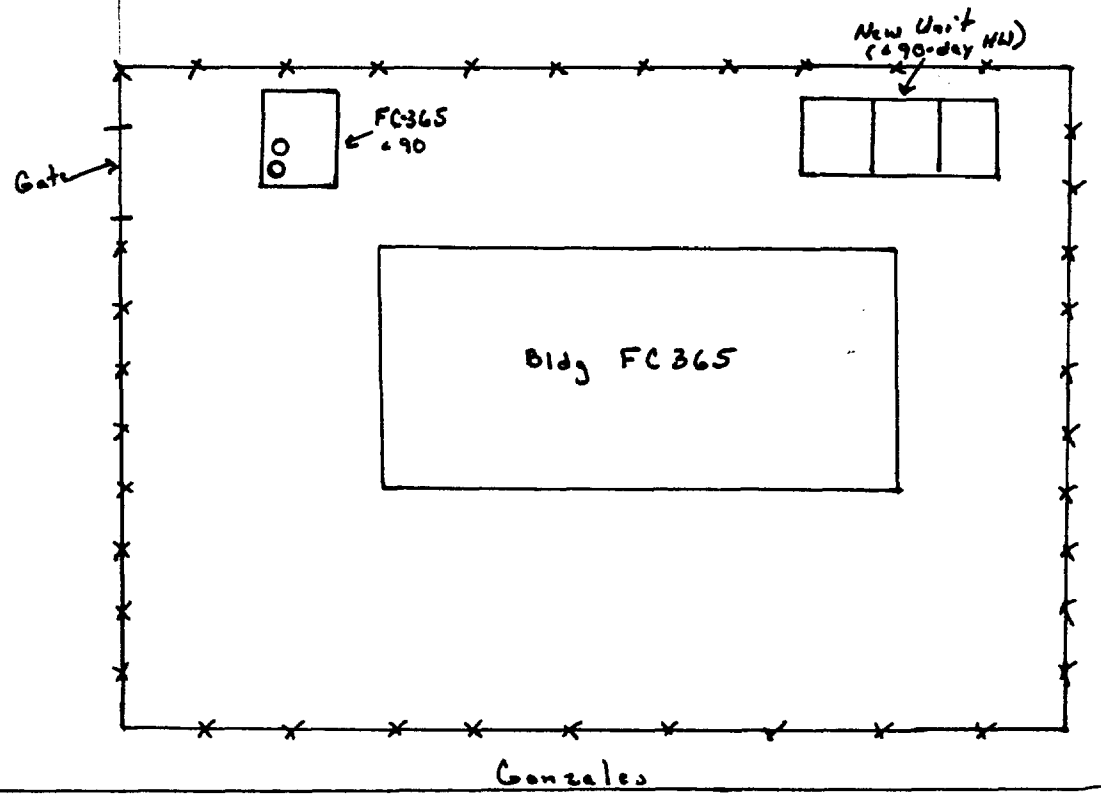

Note: New unit is currently being constructed.

ASS

12-6-93  
1415

2d SRIE 2d Radio Battalion (Motor Transport)

SFC-244 - O/W Separator

Photo 14, R.113

SFC-236 - 490 H.W. Unit

Photo 15, R.113

FC 241 - Used O/W AST

Photo 15, R.113

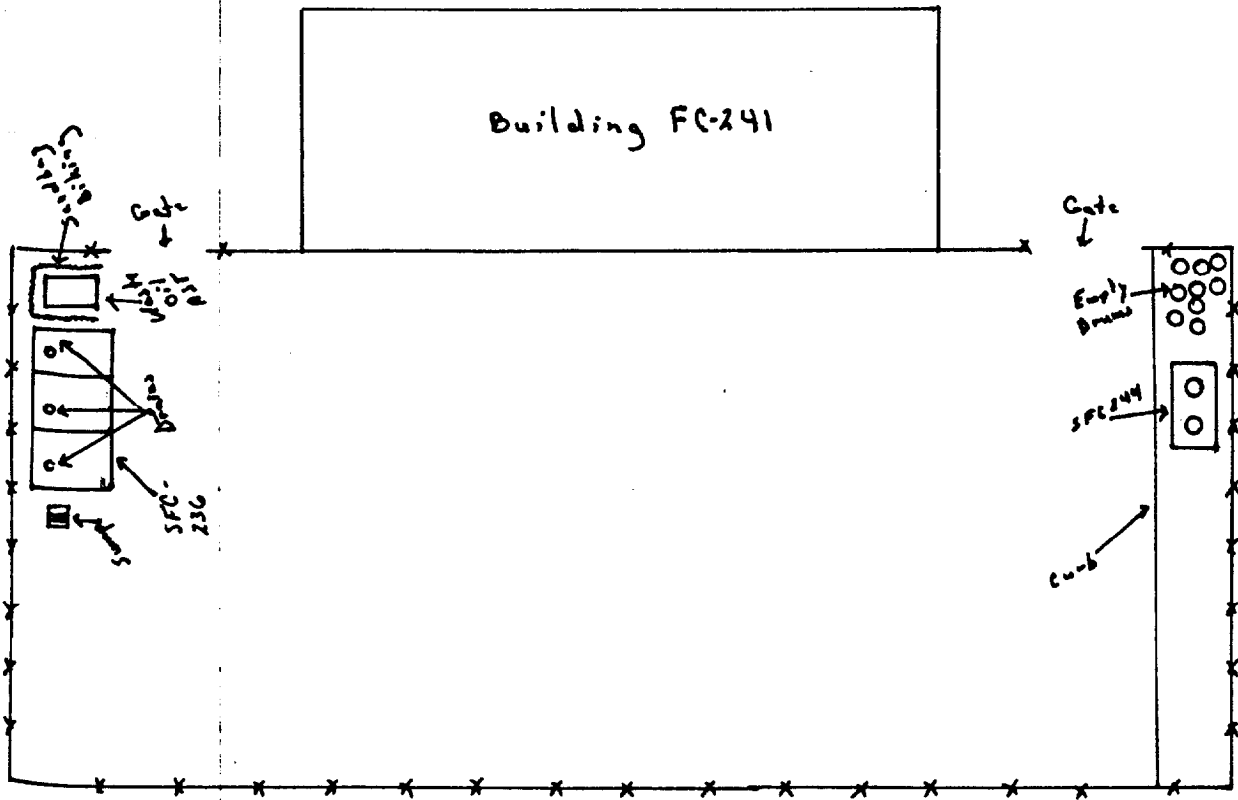

A56

12-6-23  
1445

2d SRIG Intel Company

1827 (Bay #1) - 4 90 H.W. Unit

Photo 17, Roll 3

1827 (Bay #5) - 4 90 H.W. Unit

Photo 18, Roll 3

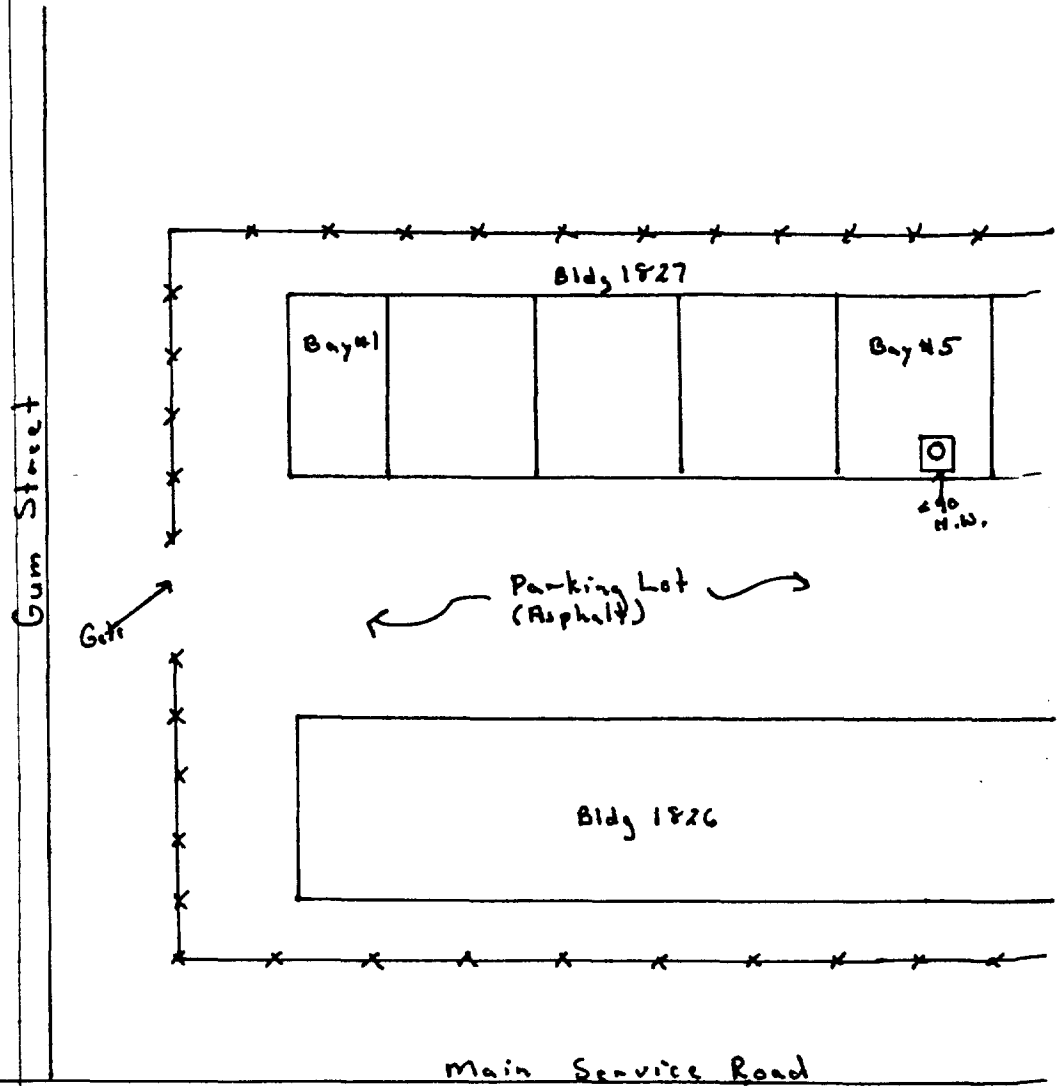

A57  
12-6-93  
1530

Base Maintenance

SM-632 - O/W Separator

Photo 19, Roll 3

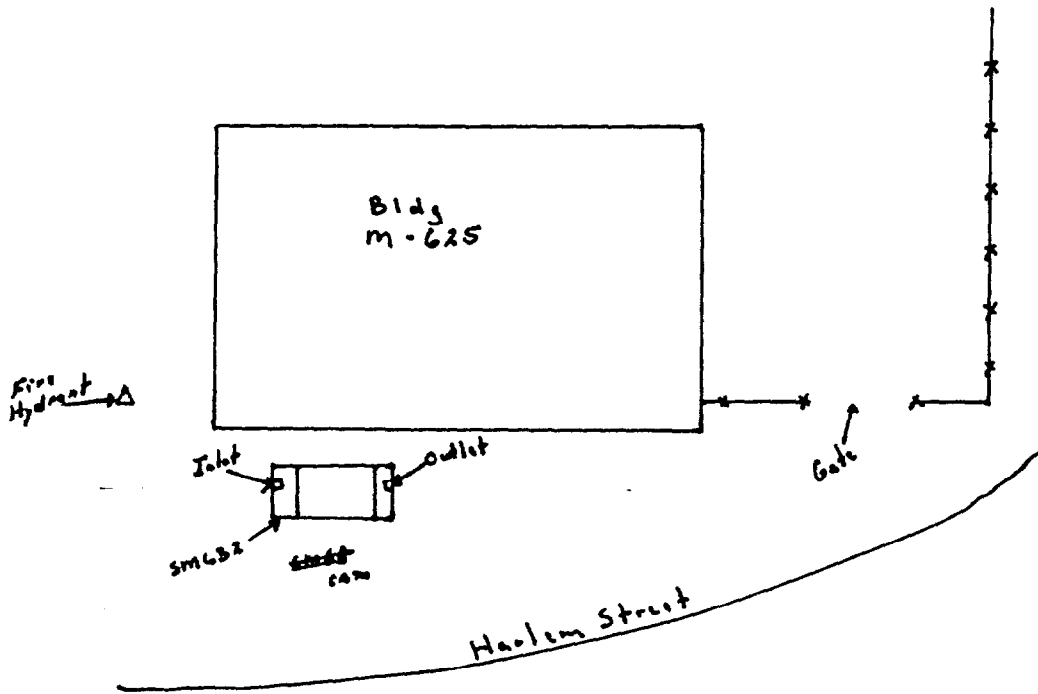

A 58

12-7-93  
1030

Motor Transport School Co.

M-107-1 - O/W Separator

Photo 20, Roll 3

M-107-2 - O/W Separator

Photo 21, Roll 3

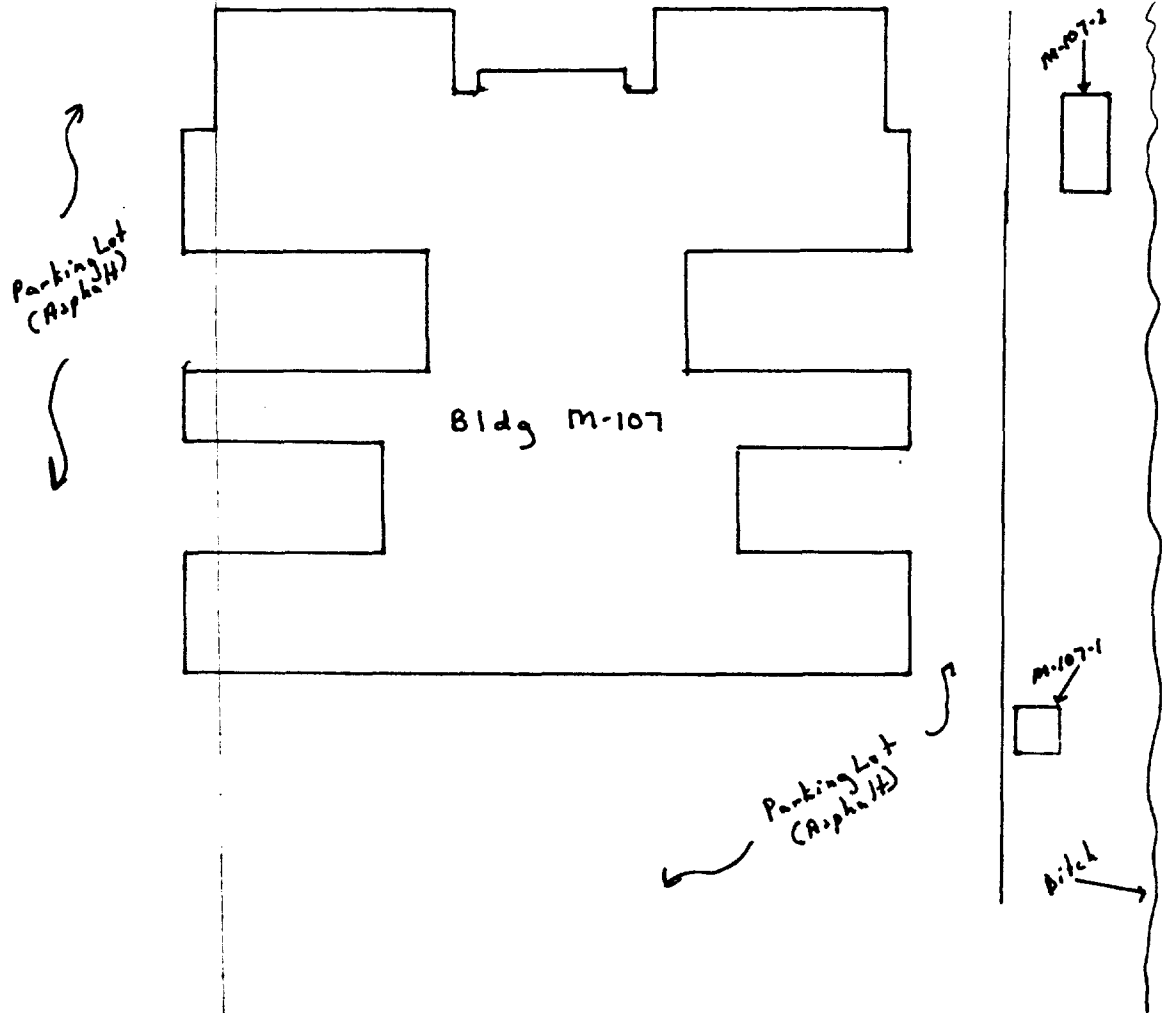



459

12-7-93  
1115

Unknown

SM-269 - Oil/W Separator

M-200 - Used Oil AST

Photo 22, Roll 3

Photo , Roll

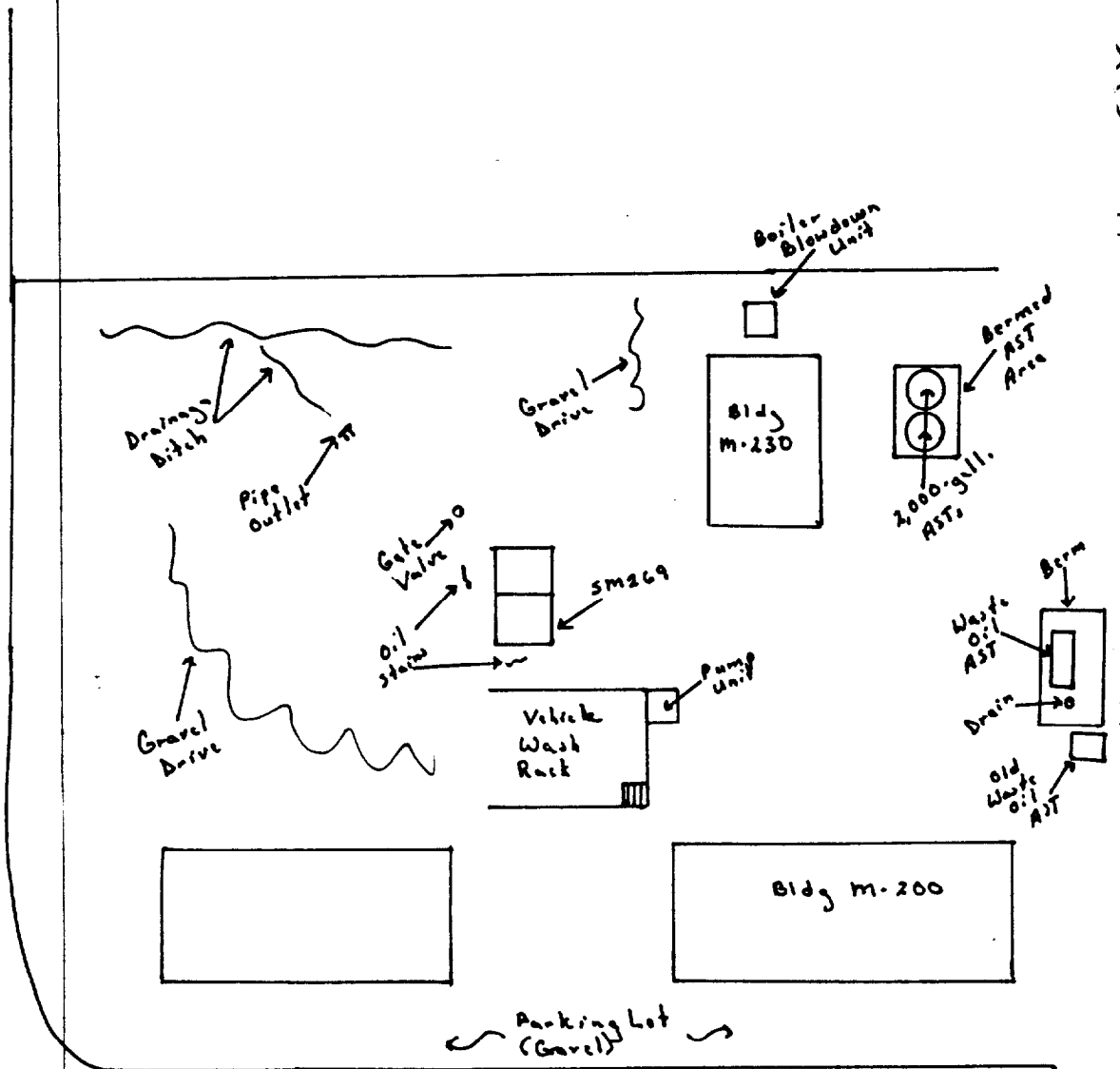

Wilson Drive

A60

12-8-93  
0900

2d Marine Division Communication Co. HQ Bn

1860 - O/W Separator

Photo 23, Roll 3

51892 - 490 H.W. Unit

Photo 24, Roll 3

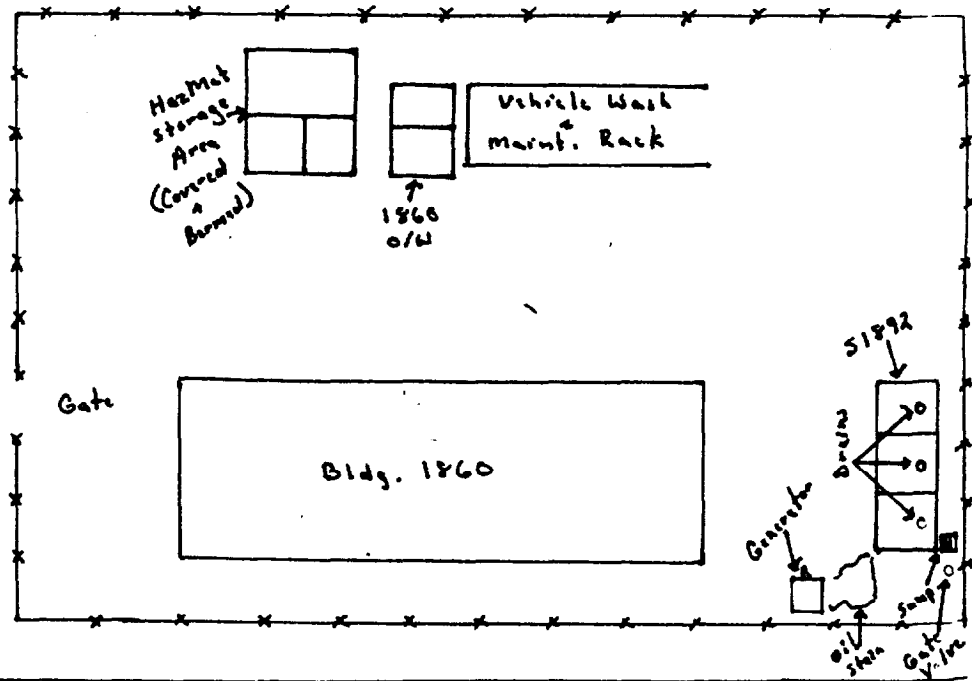

AC 1  
12-8-98  
1000

2d Marine Division Truck Co. Maintenance

1780 - 490 H.W. Unit

Photo 25, Roll 3

1780-1 - O/W Separator

Photo 26, Roll 3

1780-2 - O/W Separator

Photo ~~26~~<sup>27</sup> ~~26~~<sup>27</sup> Roll 3

1780-3 - O/W Separator

Photo 29, Roll 3

1780-A - 550-gallon UST

Photo 27, Roll 3

1780-B - 550-gallon UST

Photo 29, Roll 3

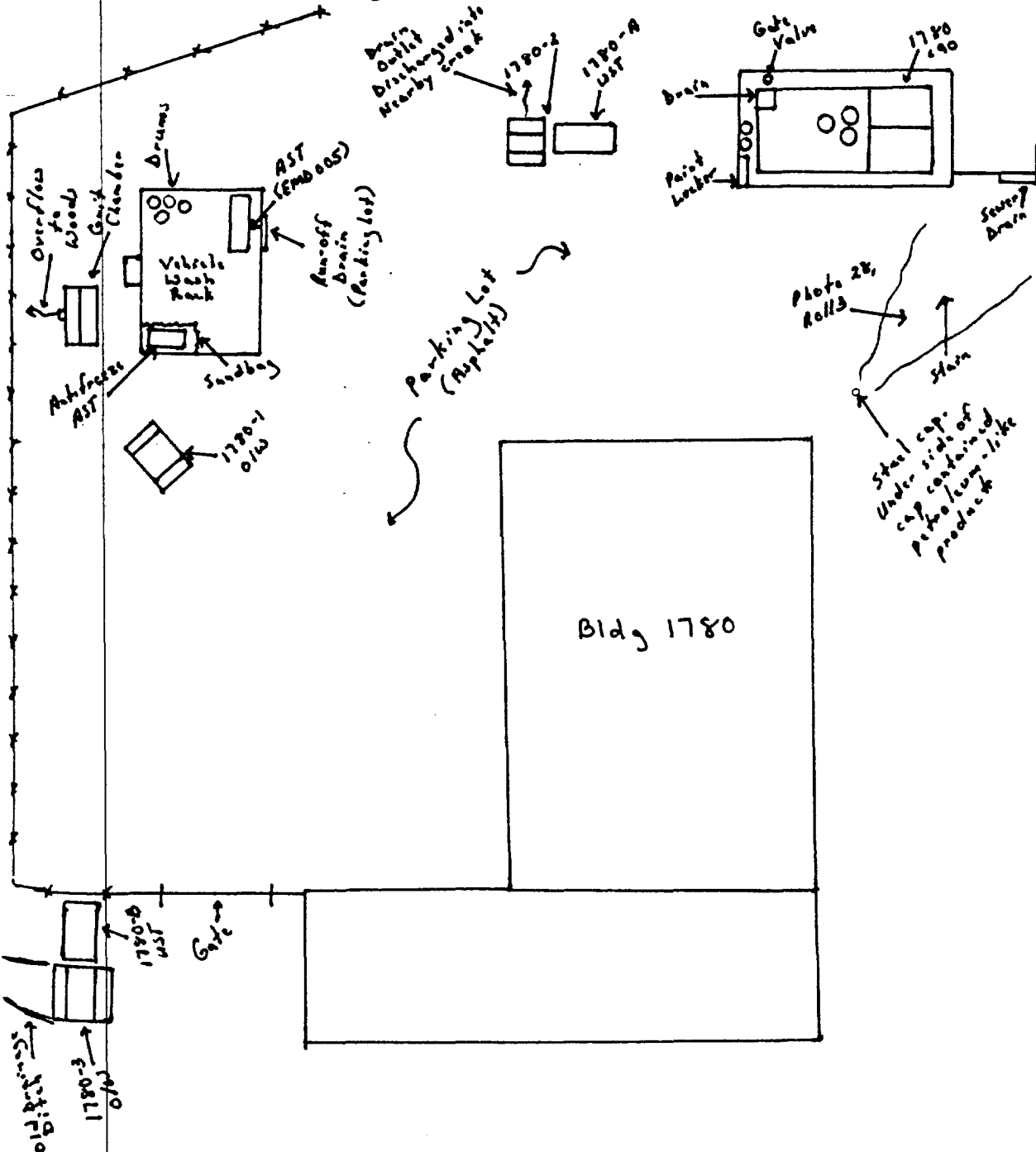

AG2

12-8-93  
1045

2d Marine Division Small Craft Co.

51753 - o/w separator

Photo, Roll

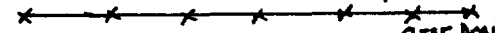
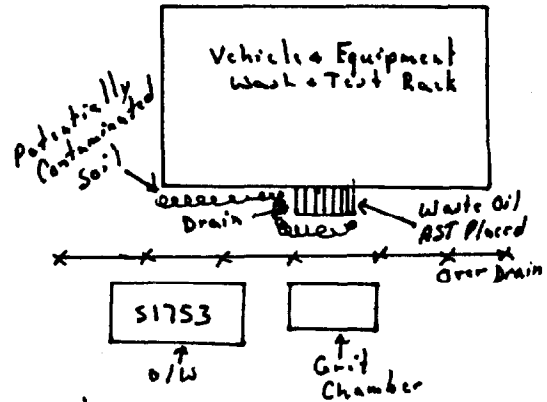
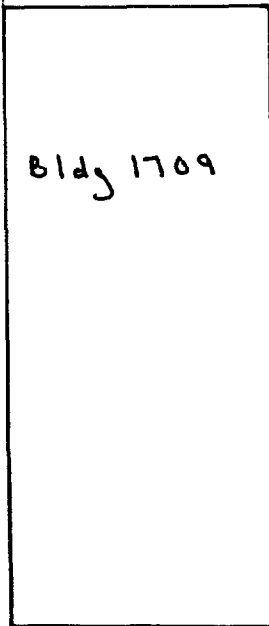

Gum Street

Hammond Rd.

AG 3

12-8-93

1100

2d Marine Division Truck Co. Operations

S1745 - O/W Separator

Photo 2, Roll 4

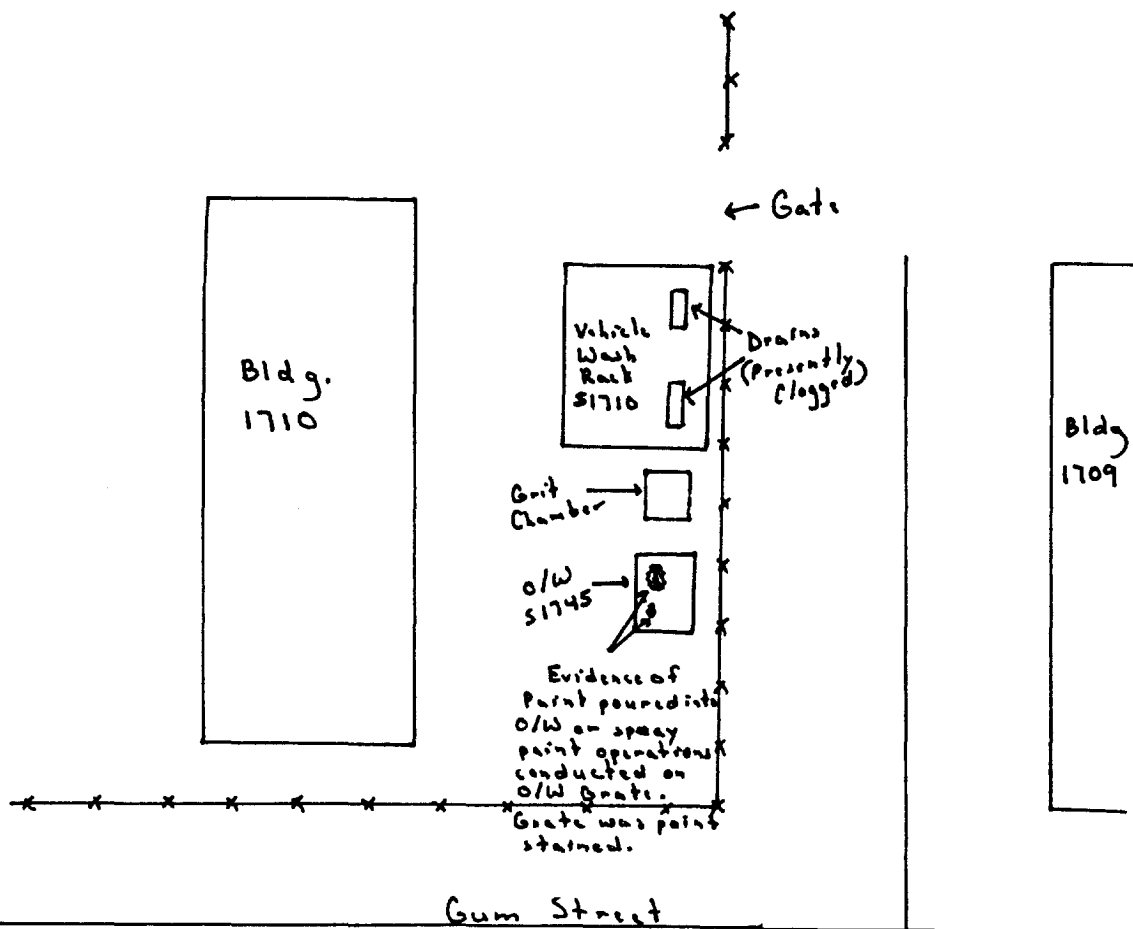

AG 4

12-9-93  
1400

Marina Gottschalk

728 - Above Ground Storage Tank (#250 G) Photo 3, Roll

Walnut  
Creek

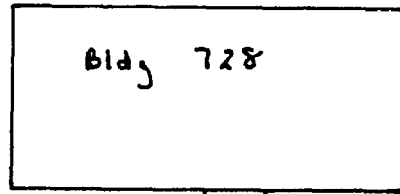

steps

USED  
671  
AST

Concrete  
Pad

Boat  
Landing

Note: AST consisted of secondary containment

A 65  
12-9-93  
1430

2d FSSG Motor Transport Maintenance  
1601 - Used Oil AST

Photo 4, Roll 4

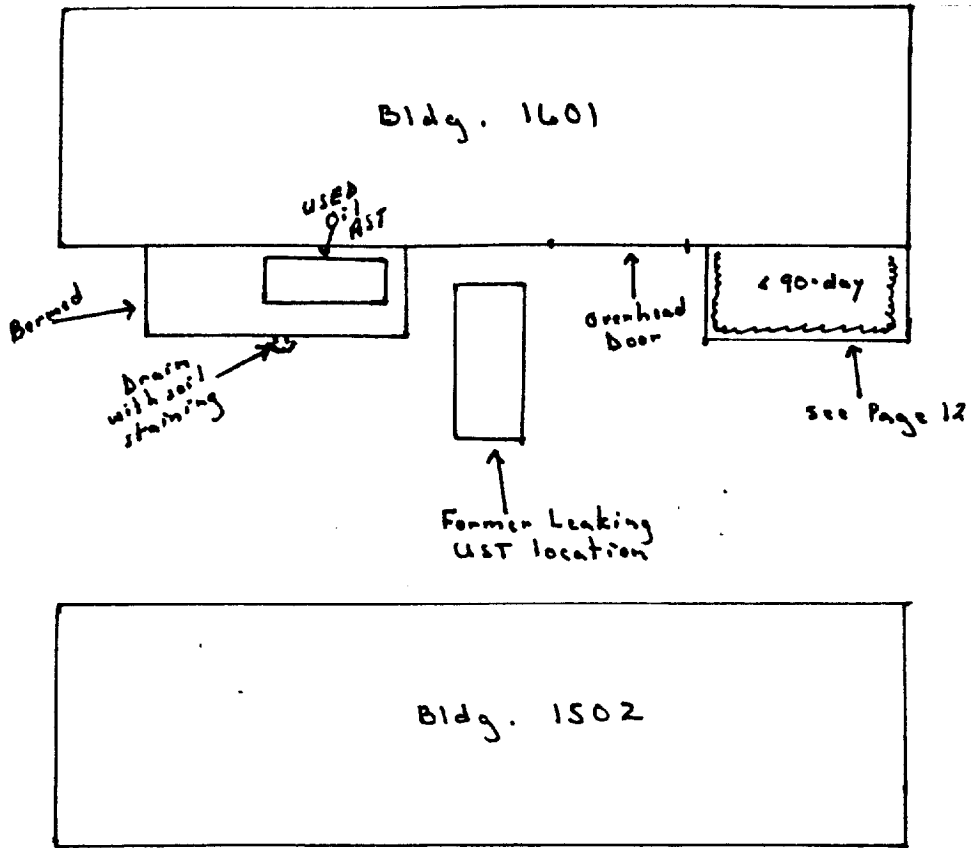

A66

12-9-93  
1515

Unknown

1607 - O/W Separator

Photo 5, Roll 4

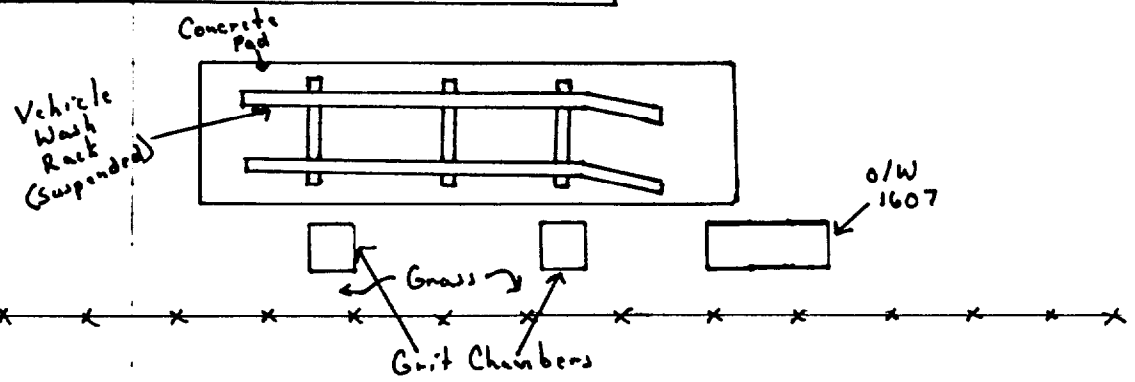
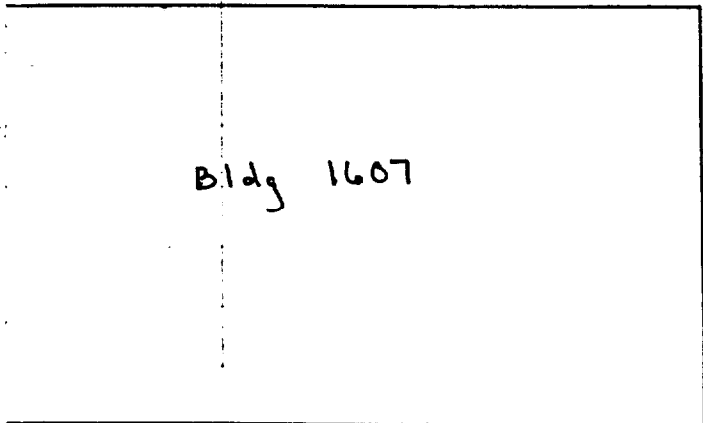



A 67  
12-9-93  
1400

# Base Maintenance

1700 - Coal Settling Pond

Photo 6, Roll 4

1700 - Spill Containment Basin

Photo 7, Roll 4

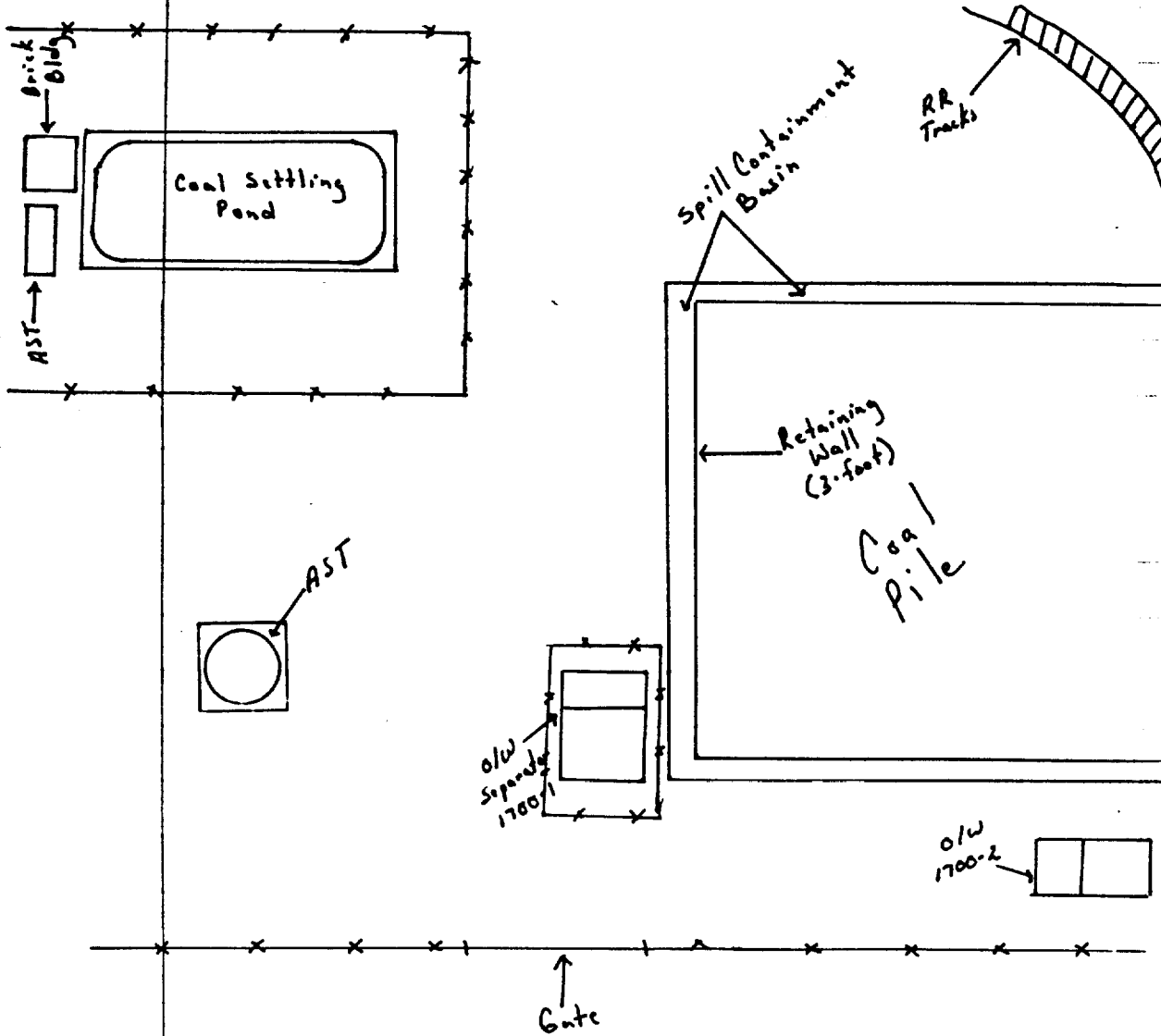

A68

12-10-93  
0900

Unknown

FC-19 - Vehicle Wash Rack

Photo 8, Roll 4

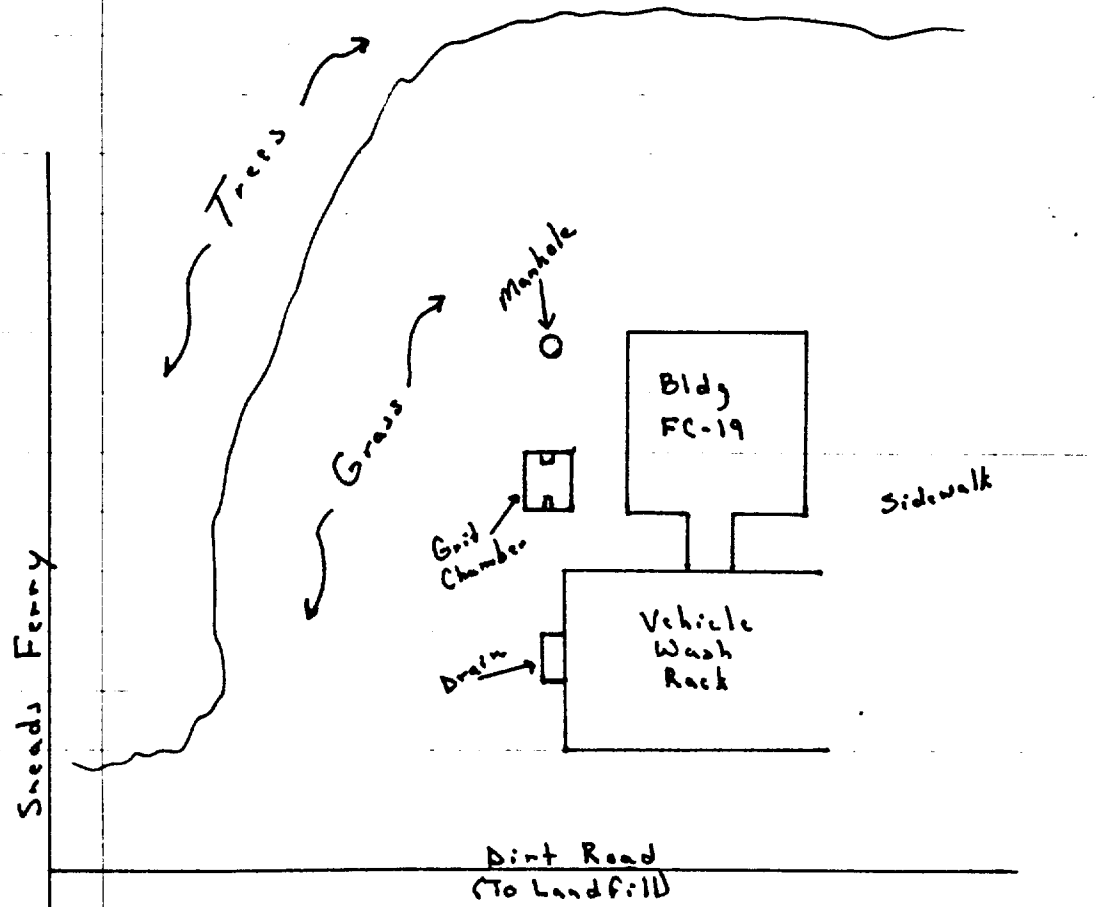

469  
12-10-93  
1000

# 6th Marines Regiment

S1836 - 490 H.W. Unit

Photo 9, Roll 4

1829-1 - O/W Separator

Photo 10, Roll 4

1829-2 - O/W Separator

Photo 11, Roll 4

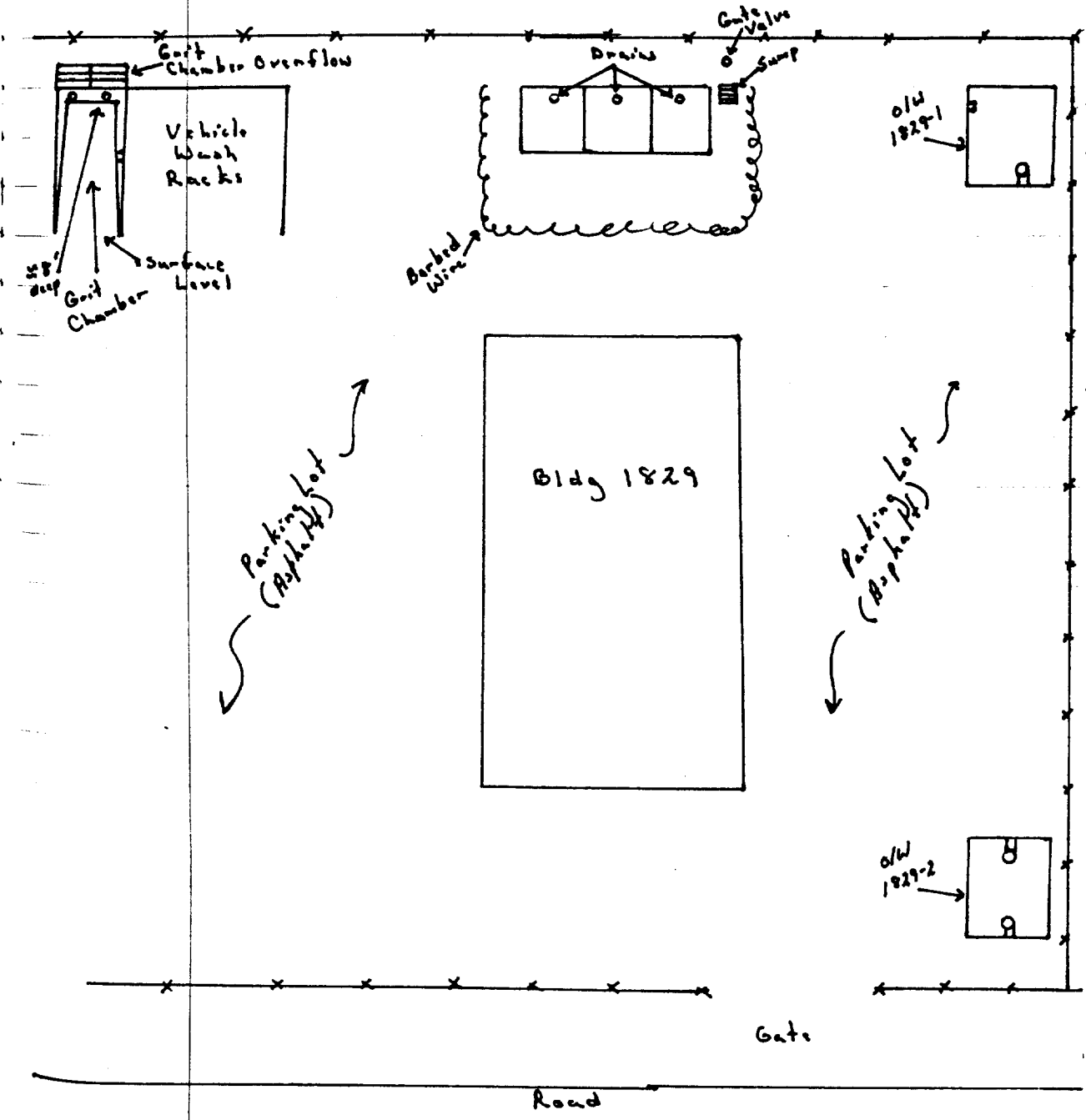

Parking lot  
(Asphalt)

Parking lot  
(Asphalt)

A70

12-10-93  
1100

Unknown

P-804-1 - O/W Separator

Photo 12, Roll 4

P-804-2 - O/W Separator

Photo 13, Roll 4

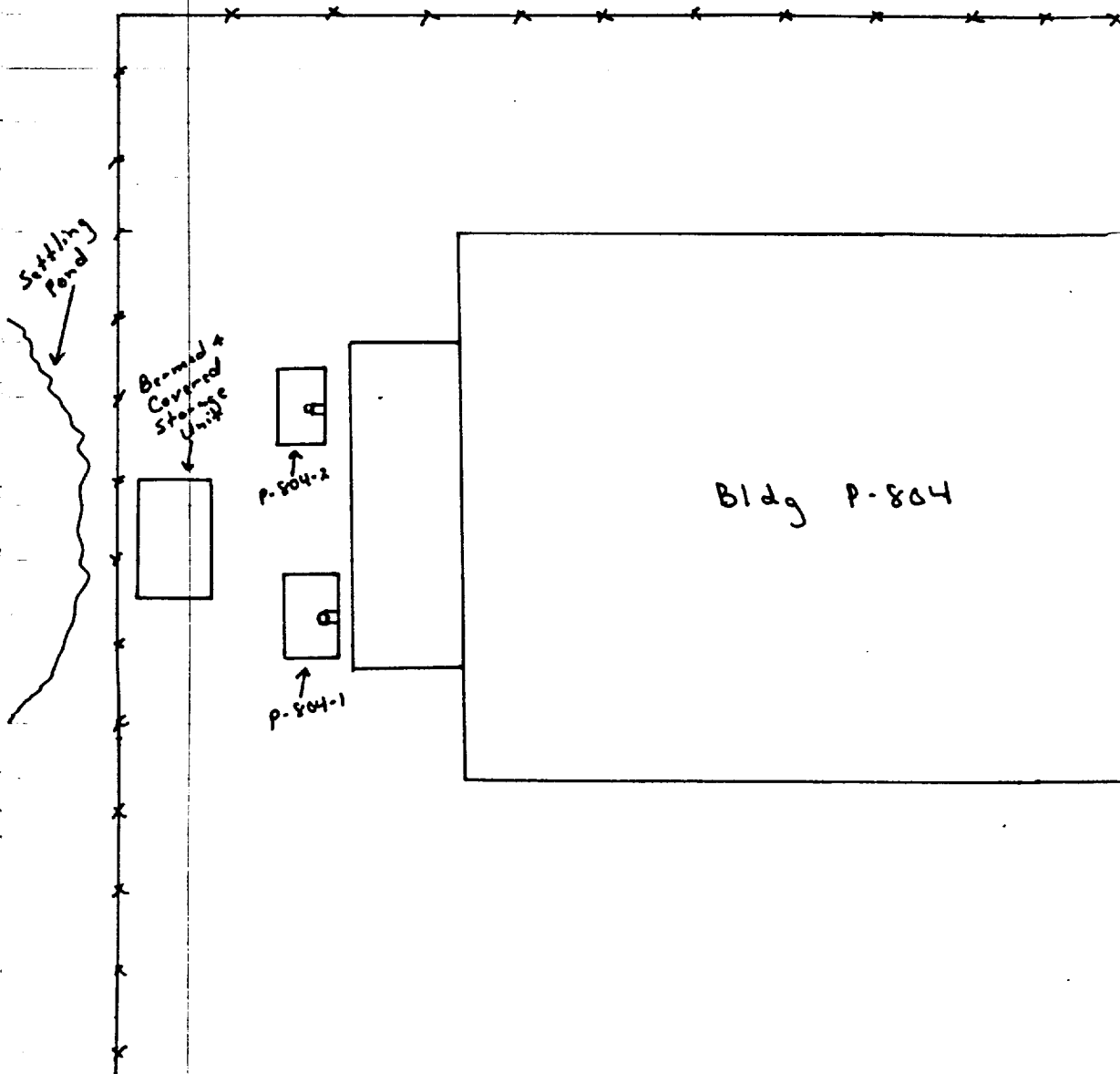

A71  
12-10-93  
1130

2d FSSG Maintenance Battalion

FC-285 - O/W Separator

Photo 14, Roll 4

SFC 284 - 490 H.W. Unit

Photo 15, Roll 4

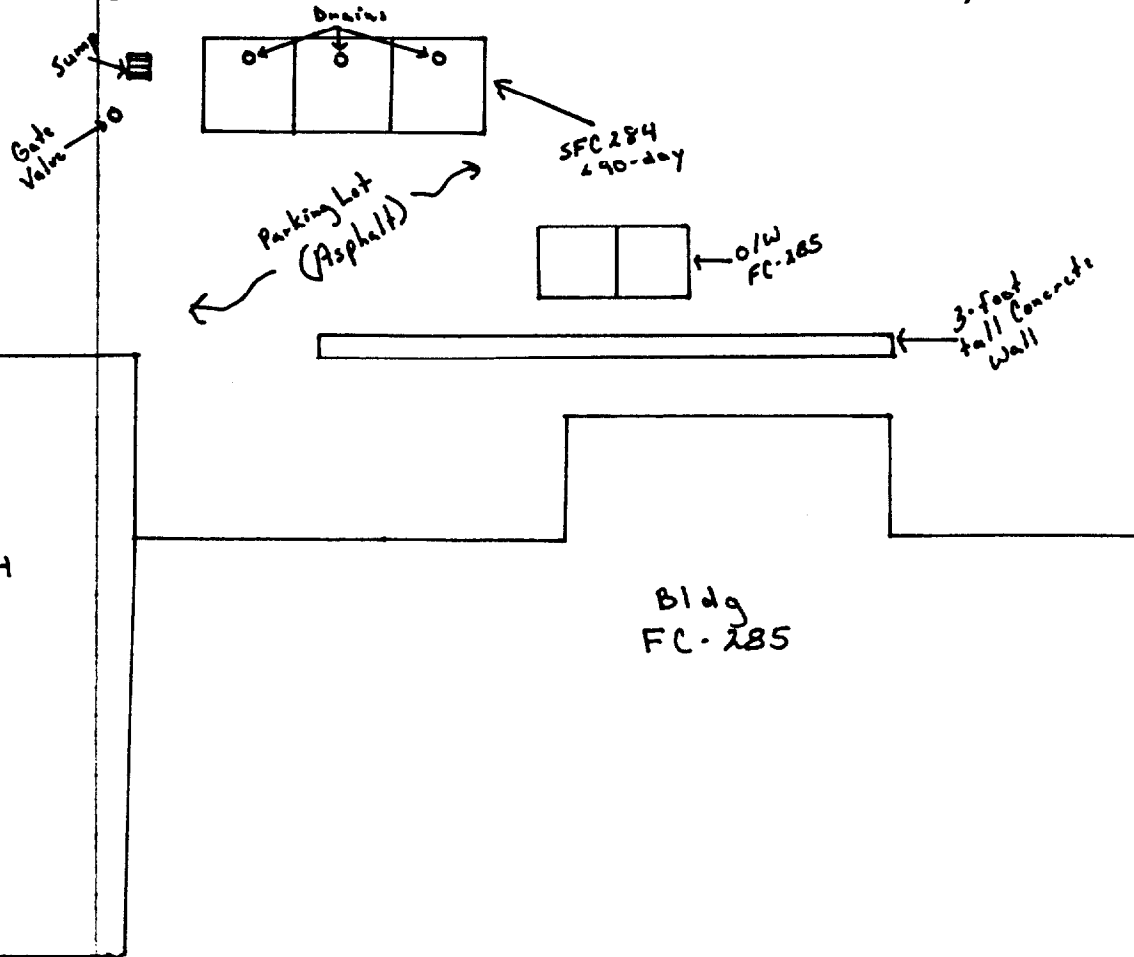

A 72

11-22-83  
1810

Base Maintenance

at AS4151. Oil Separator

Photo 23, Roll 2

White Street

---

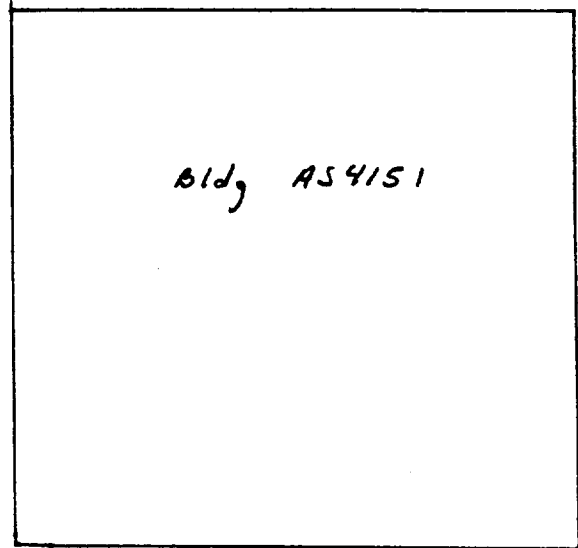

Oil Separator/  
Spill Containment  
Basin AS4151

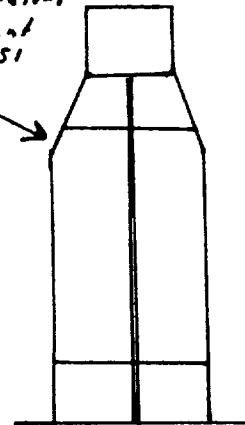

B1

2nd TANK OIL/H<sub>2</sub>O SEPARATOR  
S1854-0/w-1

11-15-93  
0800-0900  
Photo 2 & 3 Roll 5  
Room  
cm  
LB

1<sup>st</sup> Bldg. 1854

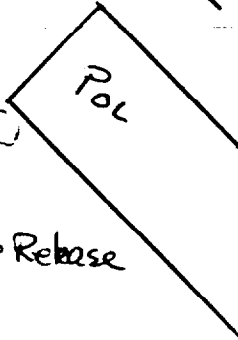
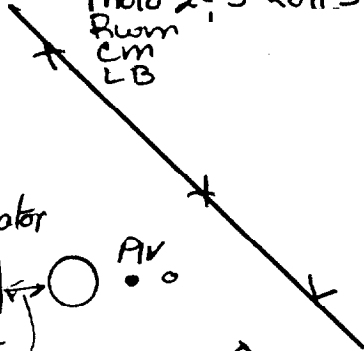
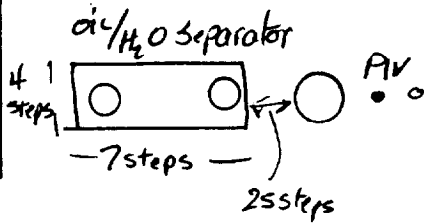
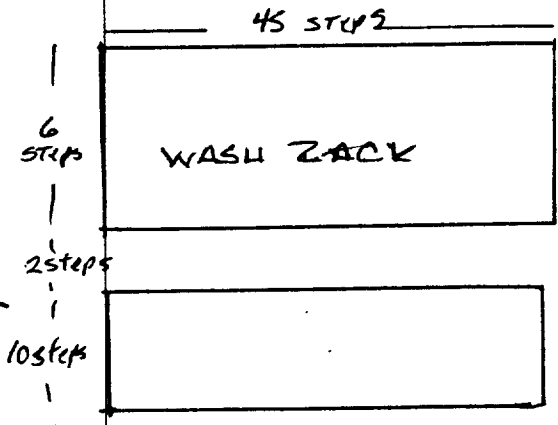

6- Hose Bibs

Photo 2

2nd TANK BN  
S1854-0/w-2

Roll 5 Photo 3

Bldg. 1854

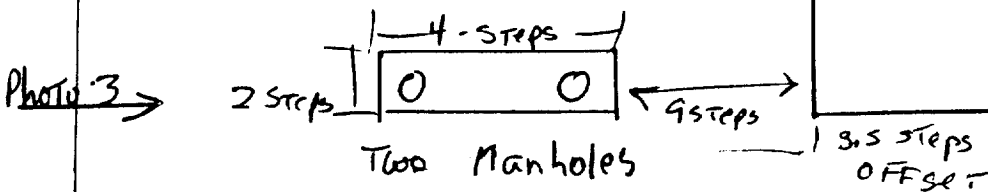
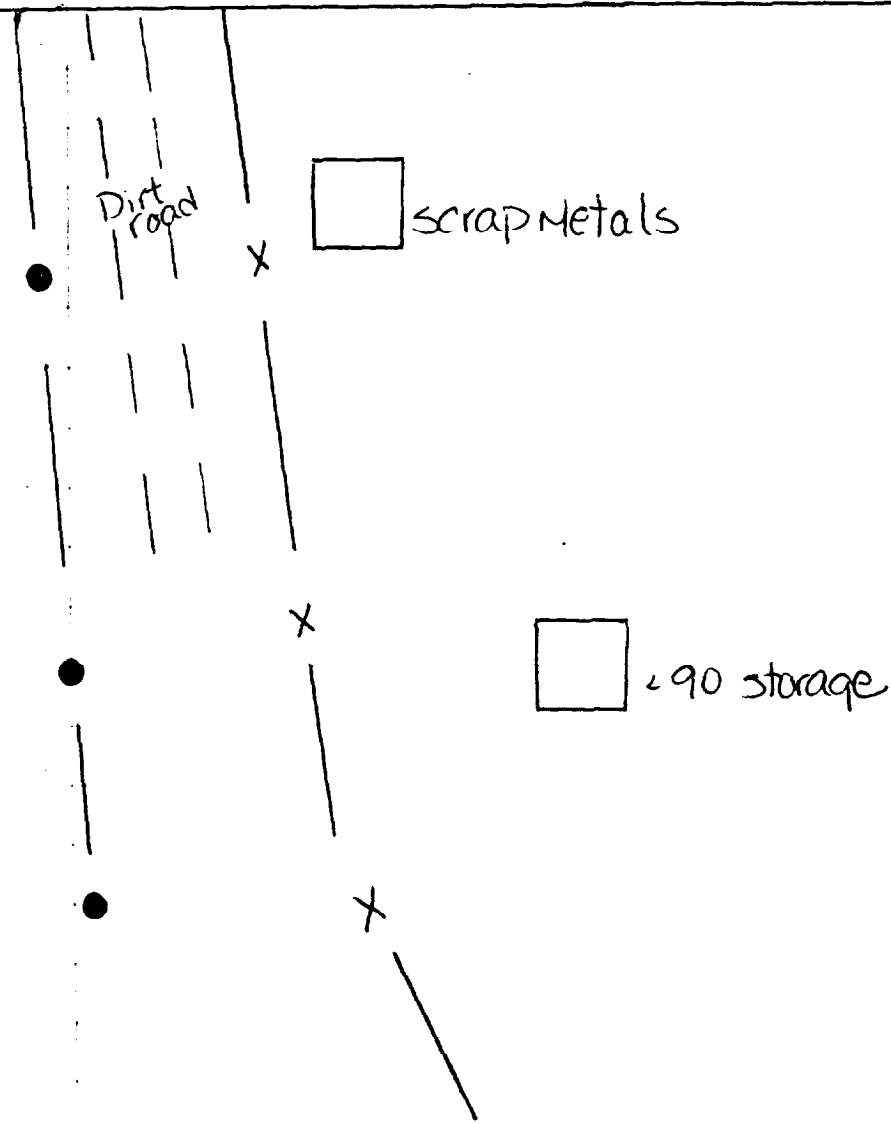
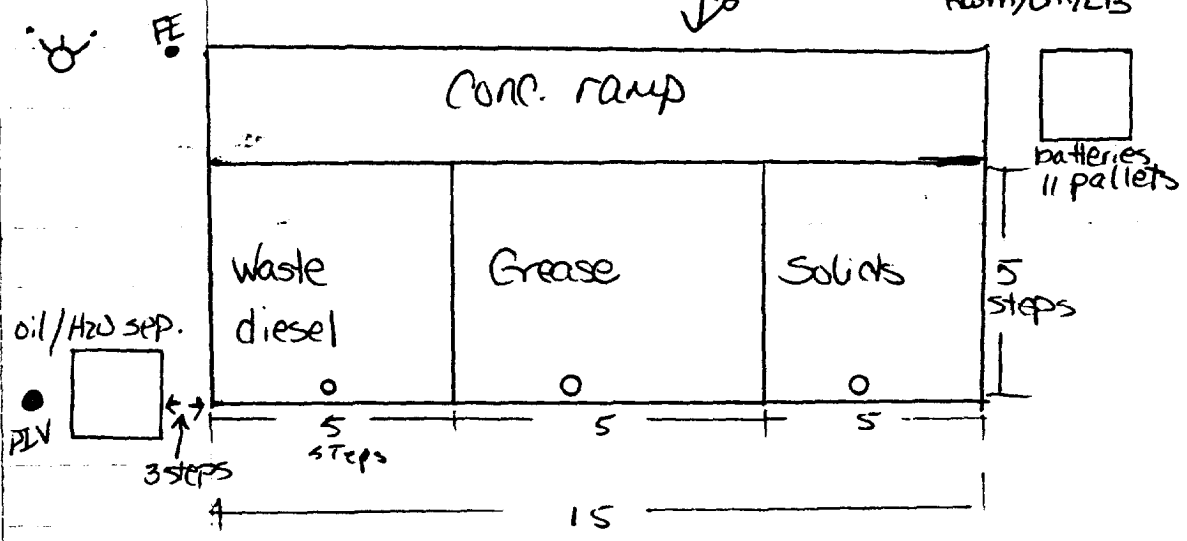

Photo 3

B-2 51854.-HWA  
2nd tank (cont)

11-15-93  
0800-0900  
Photo 1 Roll 5  
Rwm/cm/LB



Map # 4061887

Tank 1 Auto Maint Fan



S1854-UST-1 & S1854-UST-2  
2nd tank (cont)

11-15-93  
0800-0900  
No photo  
P/W/M/CM/LB

□ ← less than 90 day

□ wash rack

□  
2-6,000 gal  
UST Fuel

□  
2,000 gal  
waste oil  
UST-2

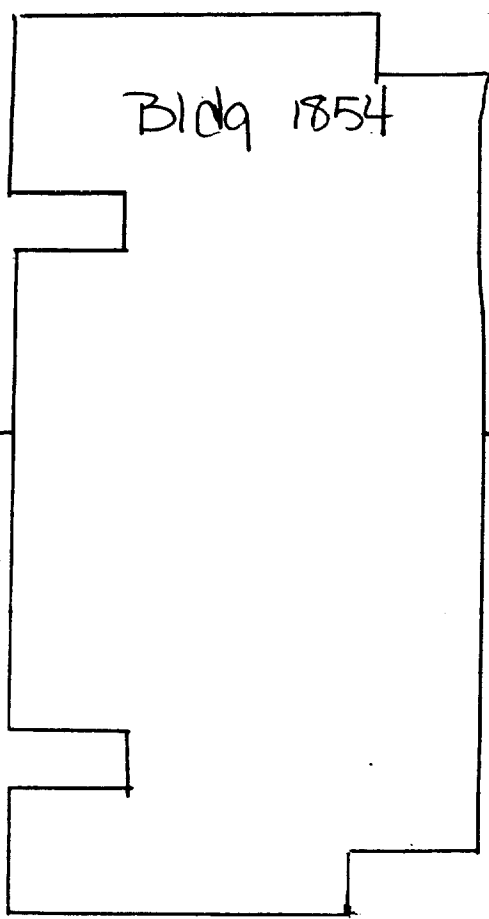

60,000  
Fuel UST

1,000 gal  
waste oil  
UST-1

□  
wash  
rack

□  
oil/H2O sep.

B4

1205-HWA & 1205-AST

H&S Company - I M&F HQSVC Co.

1205 & 1206 HWA/AST

11-15-93

Photo 4 Roll 5  
Rwm, LB

NO CATCH BASINS LOCATED

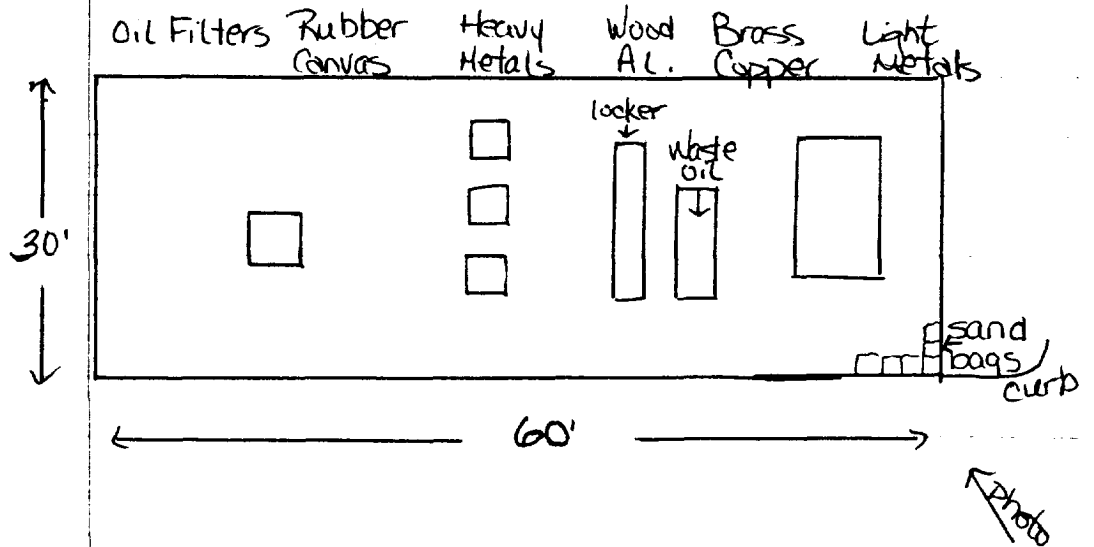

Run-off  
↑  
Vehicle Wash

Blck 1205 & 1206

Note: CPL Emory & CWO Sprague  
use to be at 1309 & 1310 prior to SRIG  
Plastics are sent to Landfill

H30-HWA; H30-AST; H30-Rack BS

II MEF #QSVC Co.

11-15-93

Engr. Maintenance Section

Photo Spills  
Room

Bldg. H30-AST

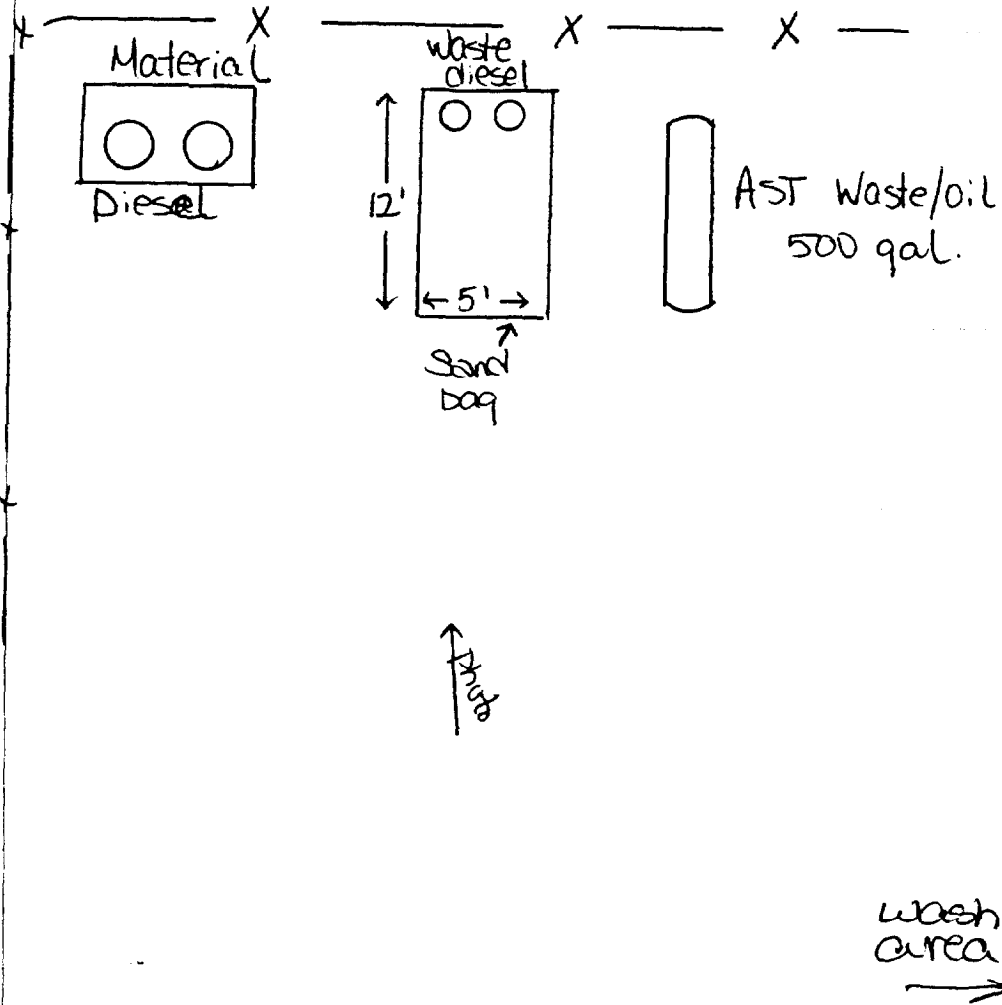

B-6

~~HHO-Rack~~ BB51-O/W-1

Wash Rack BB51 -O/W

11-16-93

Engineers School

photo Le Roll 5

Rwm

←  
Bldg.  
BB51

Photo →

DIET ↗  
↓



Oil/Water  
seperator

↑ Rail

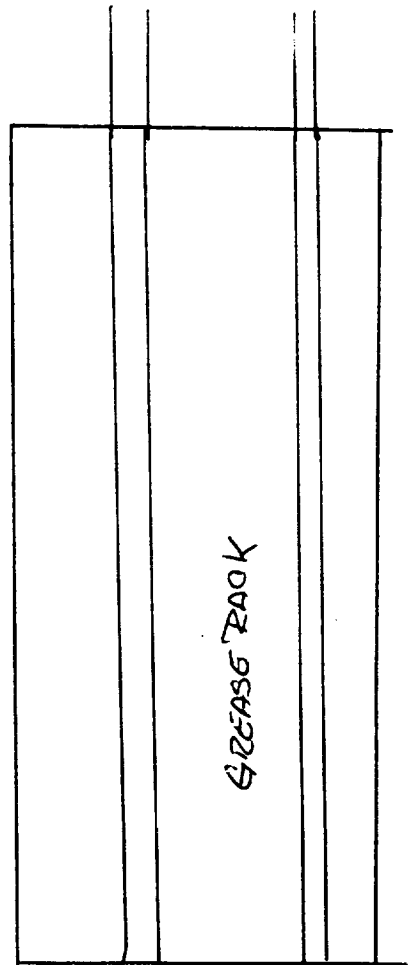

Note: Gummy Snow

BB150 o/w  
Collection Site - oil/H<sub>2</sub>O Sep.  
Engineers  
Bldg. BB-150 - o/w

B-7  
11-16-93  
Photo 7 Roll 5  
Pwm

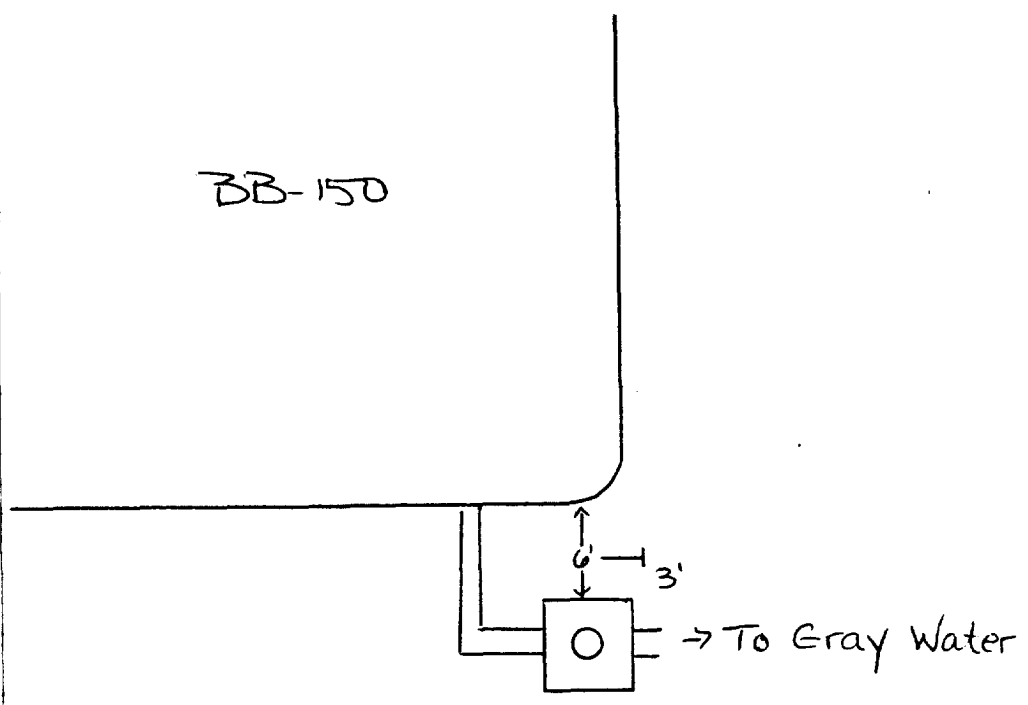

photo

Bldg. BB51

B-8

BB51-HWA-1  
Battery Shop  
Engineers School  
Bldg. BB 51

11-16-93  
Photo 8 Rolls  
Room

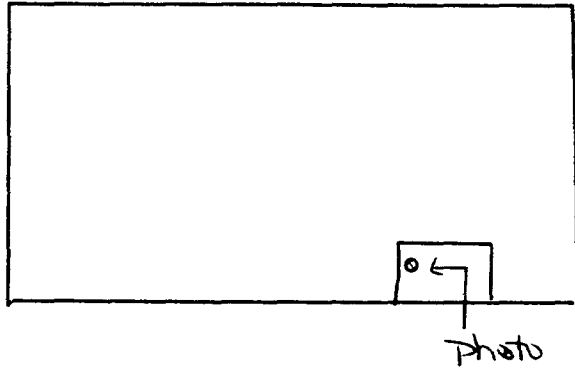

BB51-AST  
Waste Oil  
Engineers School  
BB-51

B-9  
11-16-93  
Photo 9 Roll 5  
Rwm

BB-51

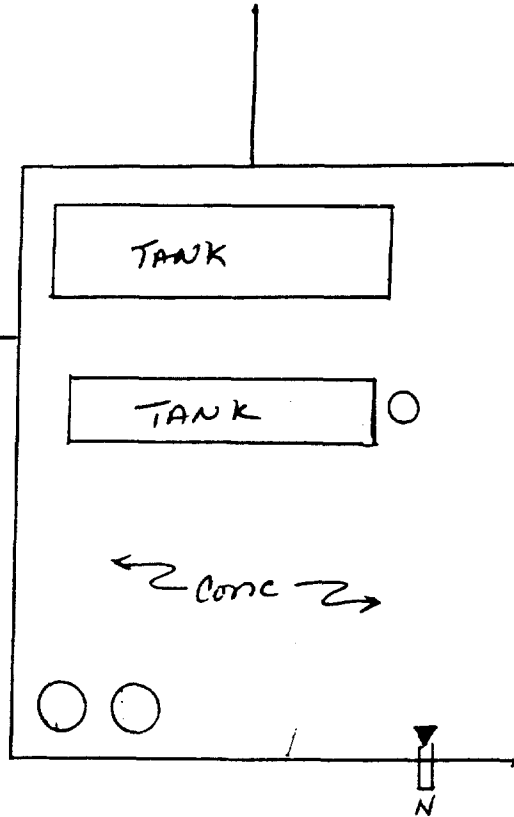

Photo

B-70

BB52-0/w-2

BB-52

Engineering School

11-16-93  
Photo 10 Roll 5  
Room

Photo

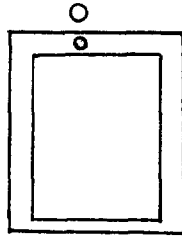

X — X



SBB 135-HWA  
SBB 135  
Engineers School  
290 DAY

B-11  
11-16-93  
Photo II Roll 5  
Bwm

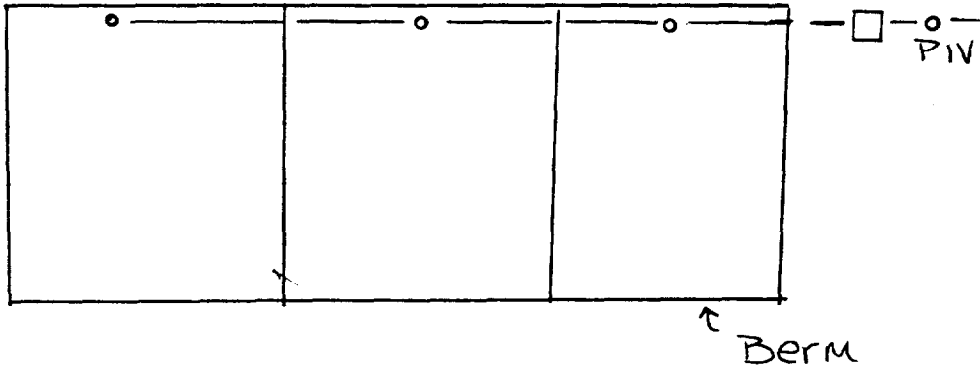

Photo ↗

B-12

SBB169-0/w SBB169-AST

Wash Rack

SBB 169

Engineers School

11-16-93

PHOTOS 12:13

Roll 5

Rwm

unknown date

290 DAY

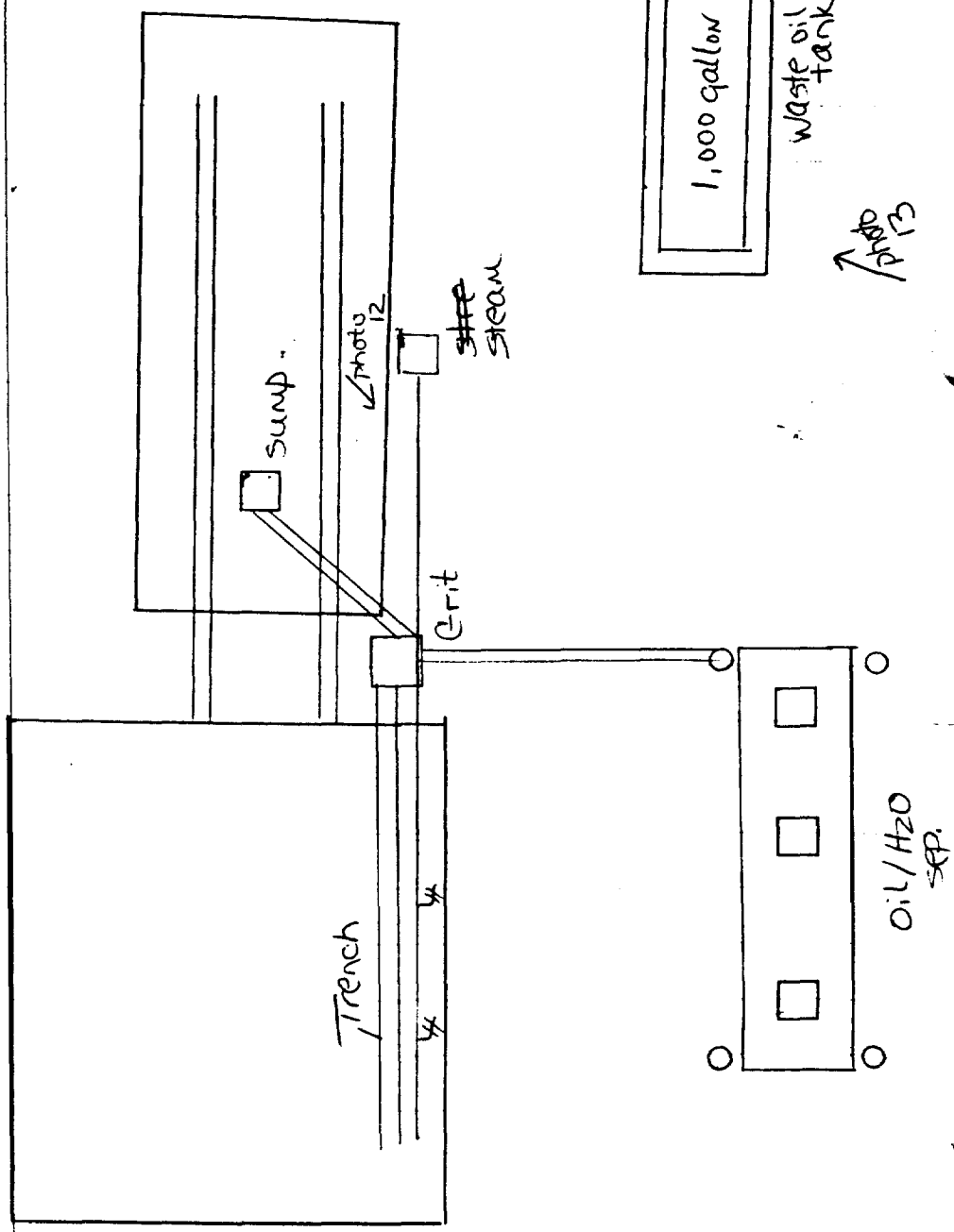

SBB241-0/w  
Oil/H<sub>2</sub>O Sep.  
Engineers School

B-13

11-16-93  
Photo 14 Roll 5  
Rwm

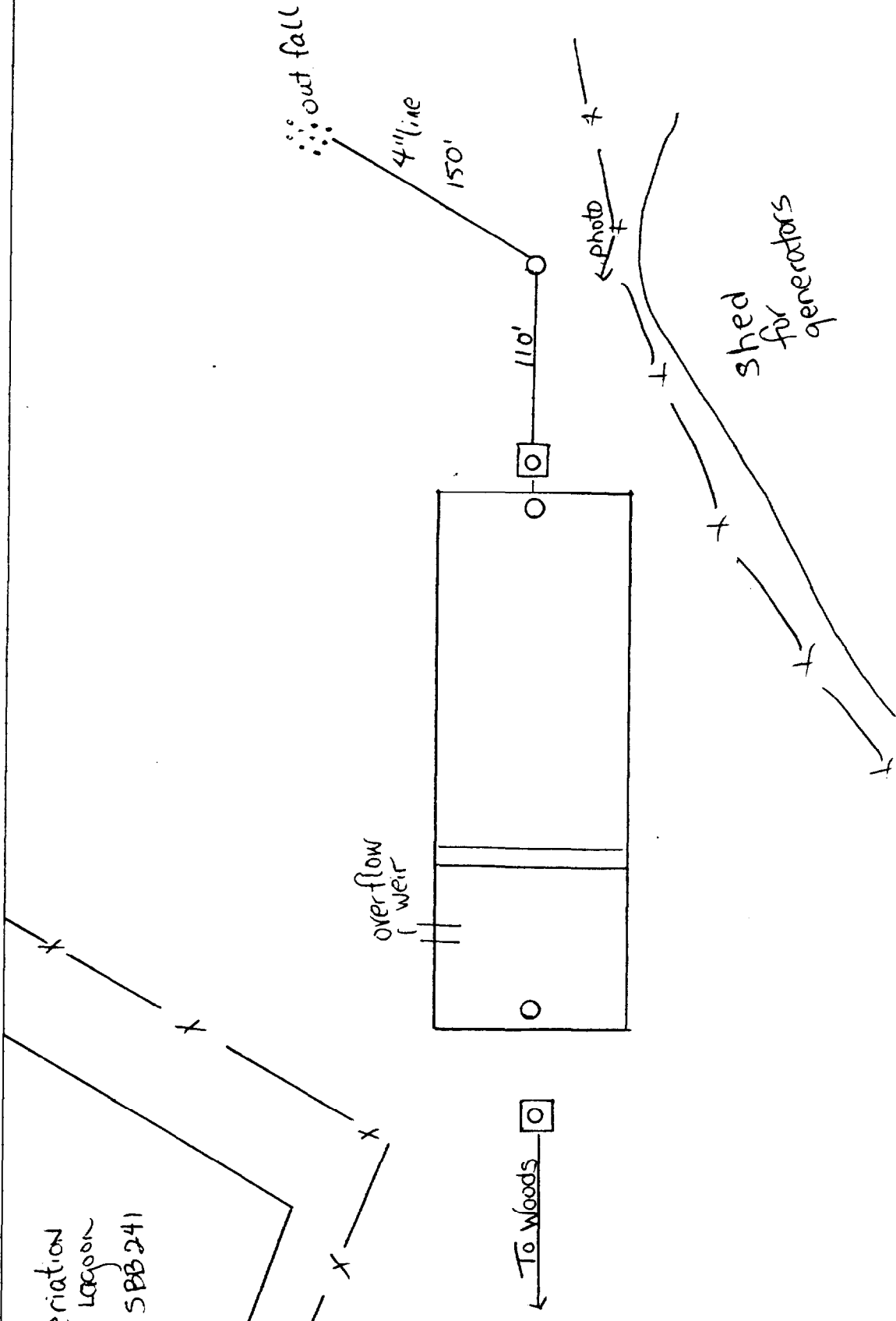

B-14

BB293-0/w

BB-293

Engineers School

11-16-93  
PHOTO 15 ROLLS

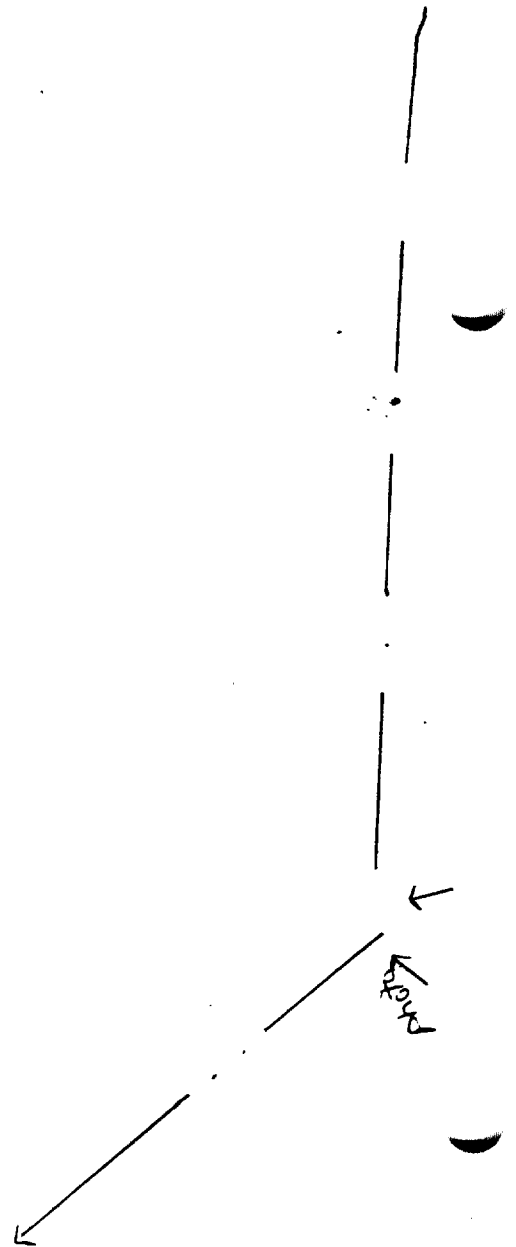
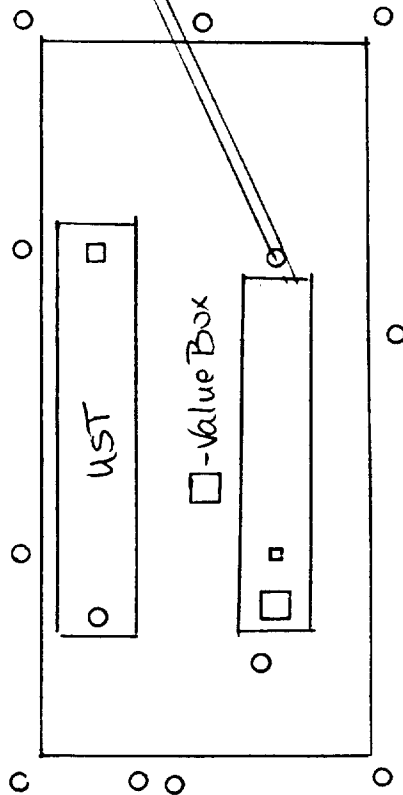
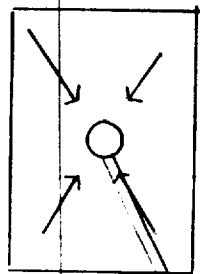
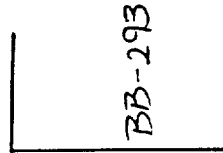

HP100-0/w HP100-UST  
8th Marine  
H-100 Motor T

B- 15.

11-16-93  
Photo 16 Roll 5  
Rwm  
Photo 19 Roll 5

Inside Bldg H-100

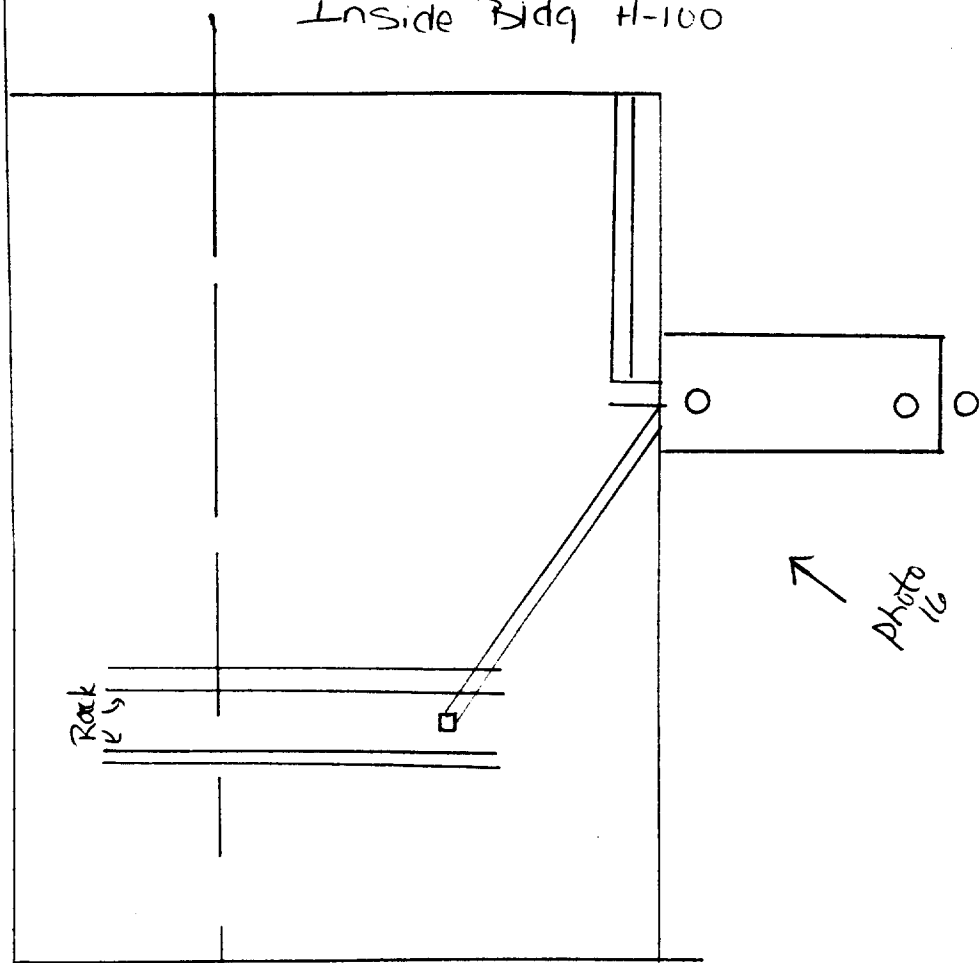

Asphalt ~

550 gallon UST  
Waste Oil

Fuel Dispensers

Photo 19

B-16

HP100-HWA  
290 DAY  
8th Marine

11-16-93  
Photo 17:18  
Roll 5  
Rwm

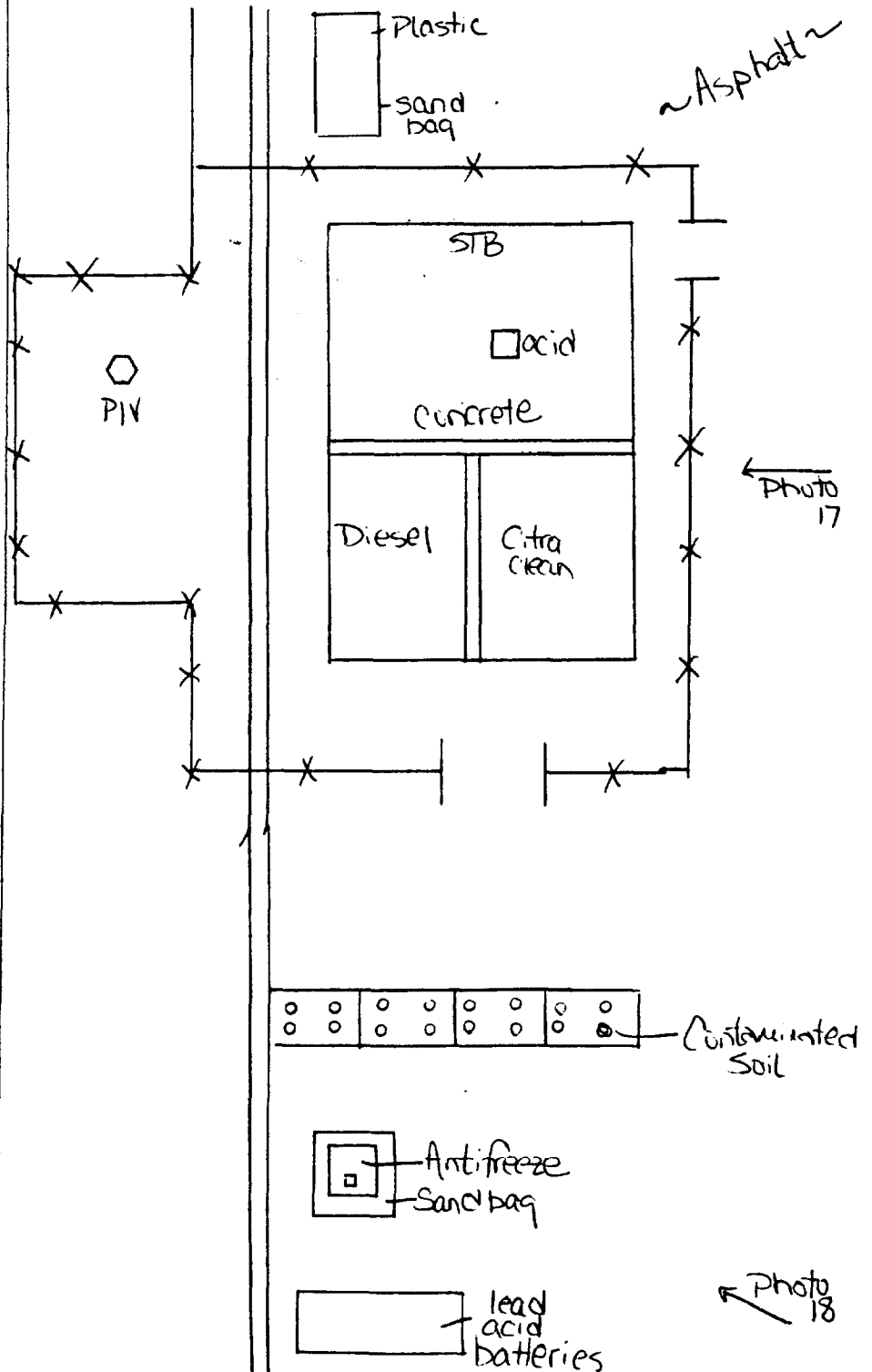

HP104-HWA  
H-P - 104  
8th Marine  
Com. Center

B-17  
11-16-93  
Photo 20 Roll 5  
Rwm

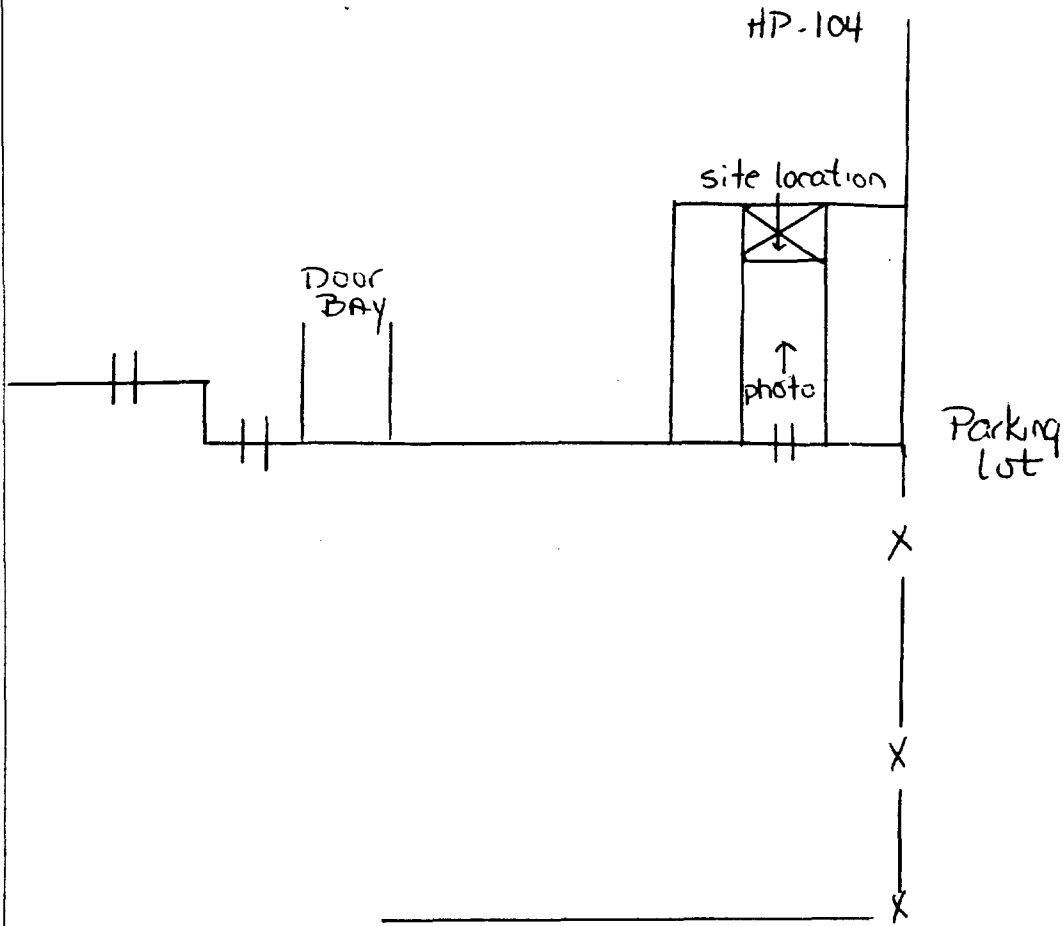

B-18

1450-HWA  
2nd Marine Artillery  
5/10 th

11-16-93  
Photo 21. Roll 15  
Bwm

Bldg 1450

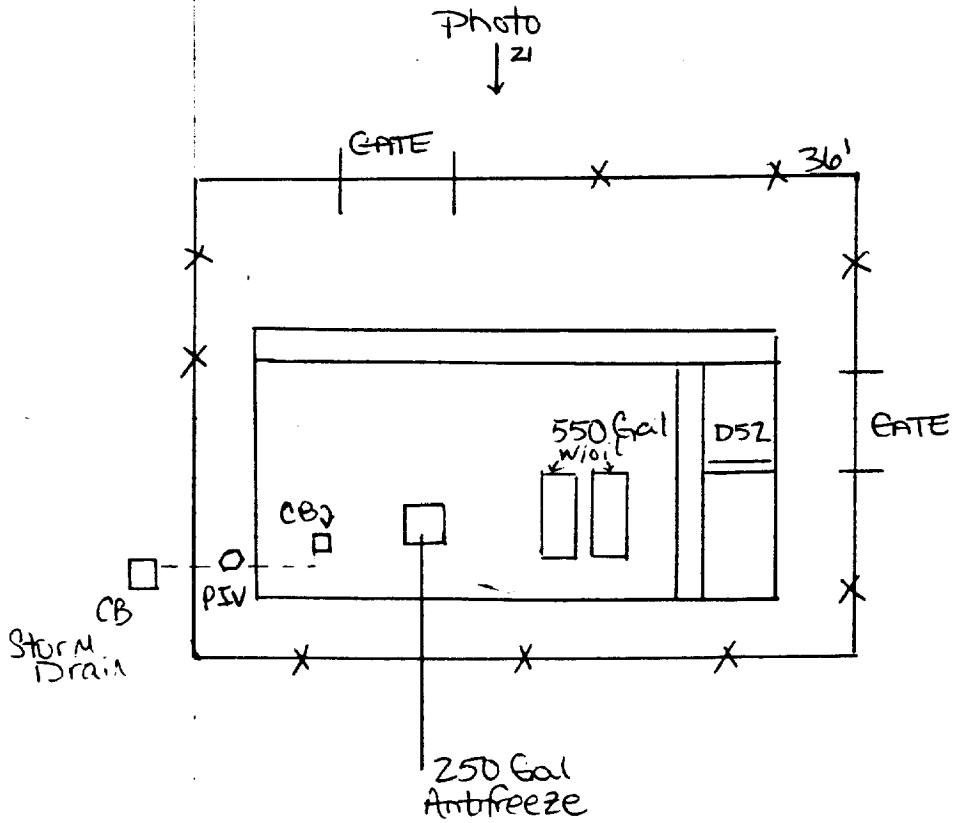



1450-0/w-1

5/10 th Artillery Maint.

B-19

11-16-93

Photo 22 Roll 15

Rwm

Photo  
o/w →

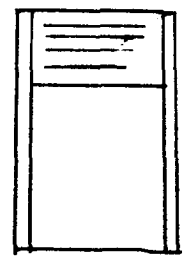

o

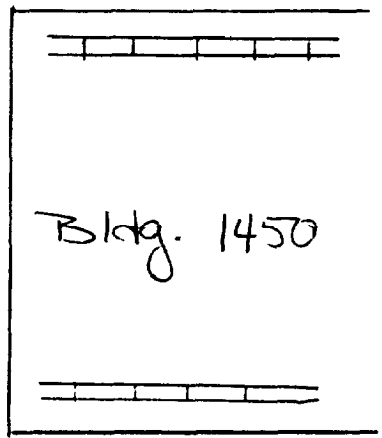

B-20

1450-0/w-2

5/10th Artillery Maint.

Wash Rack - oil/H<sub>2</sub>O Sep.

11-16-93

Photo 23 Rolls

RM

Bldg. 1450

↓ photo

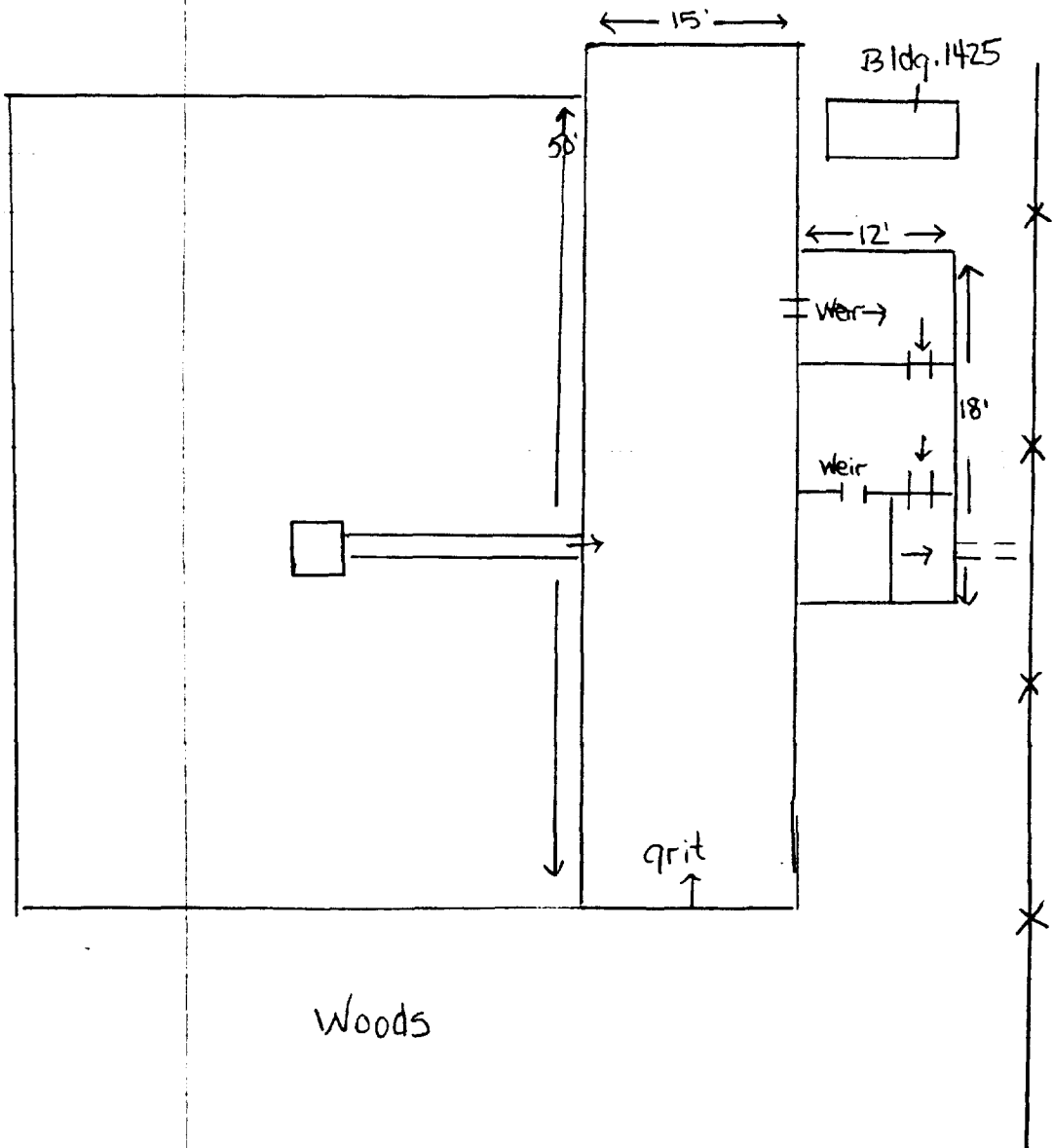

034-Ditch  
5/10th  
Stormwater Discharge Study  
Outfall 034

11-16-93 ~~21~~  
Roll 5  
Photo 24  
Room

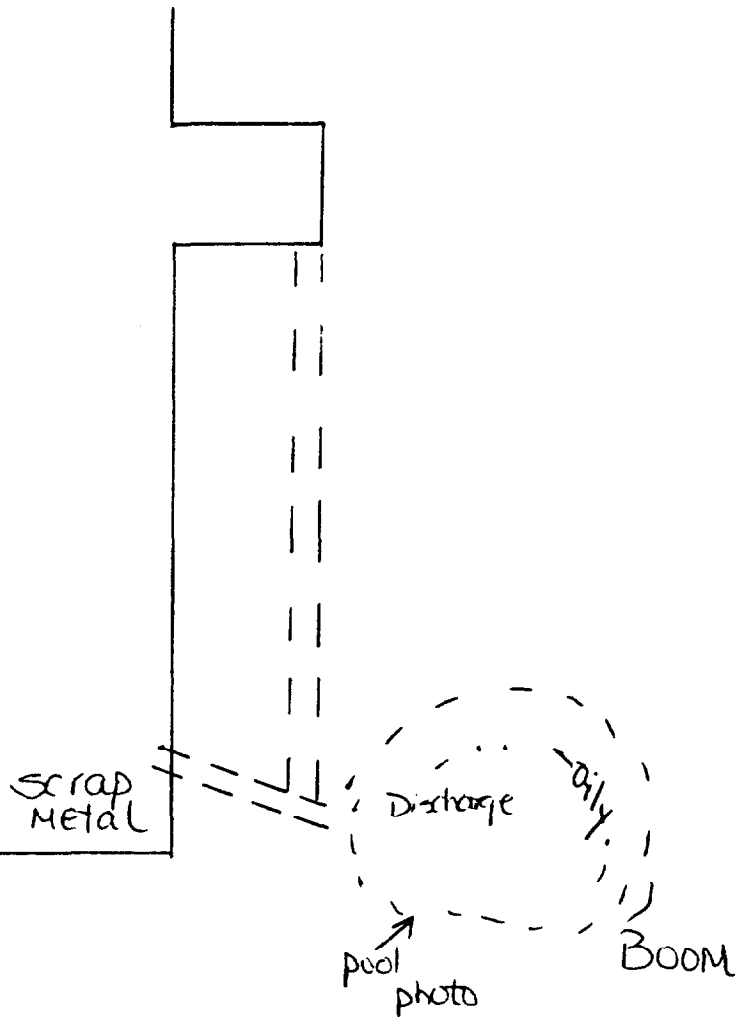

B-22

BB214-Pile  
Boat house

11-16-93  
Roll-5 Photo 25  
Rwm

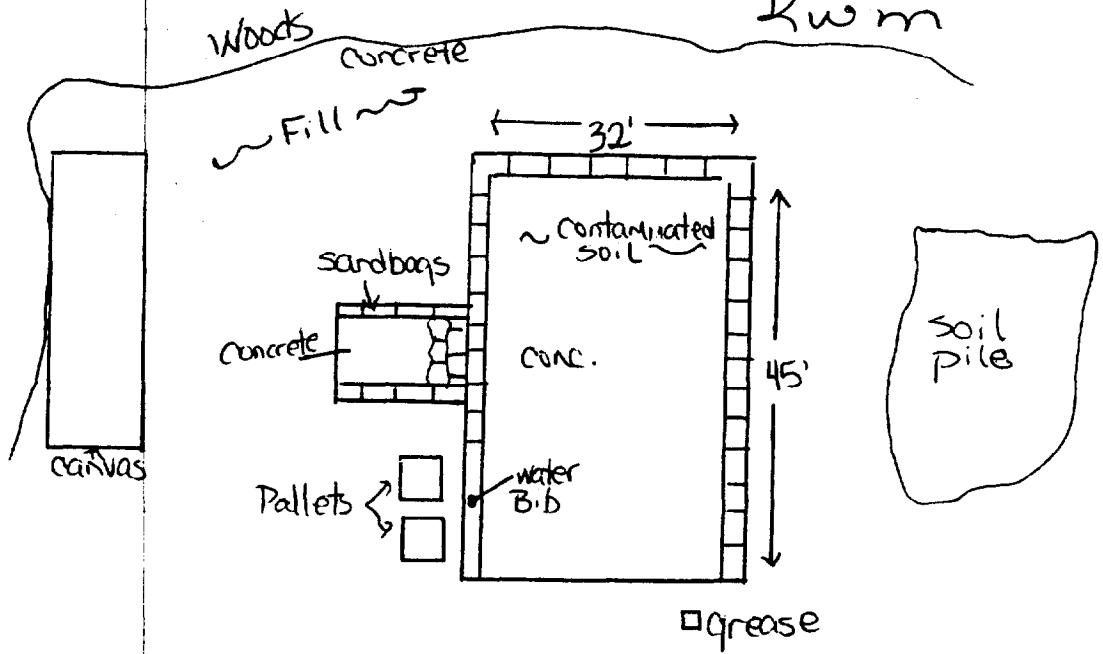

↑ photo 25

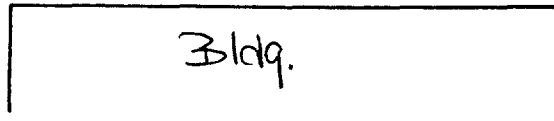

BB9-0/w BB9-Basin

B-23

Boathouse

11-16-93

Oil/H2O Sep. Grit Chamber

Roll 5

Photo 26 e

Photo 27

Rwm

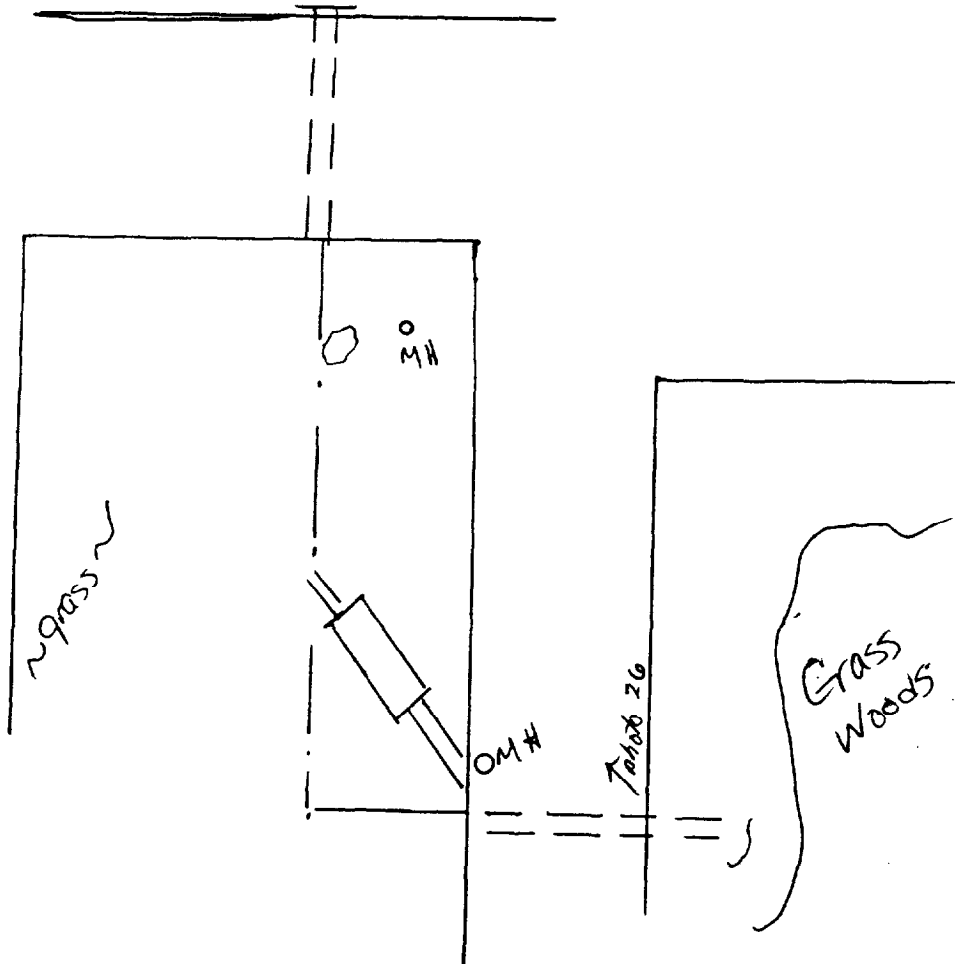
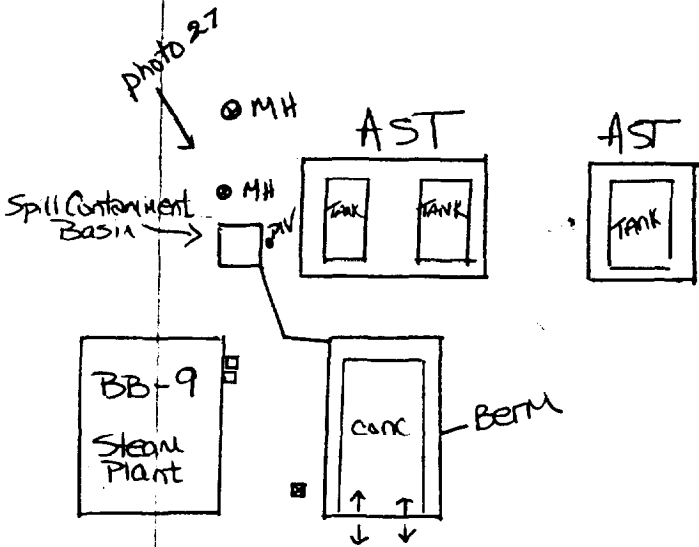

B-24

2611-Container

BOQ

Drive by

4-16-93

Koll 5

Photo 28

Rum

WATER

WOODS

unknown

gas can

released

sand cover

Tar looking substance

Rhodorsite  
silicones

Bldg.  
2611

Bottom eaten out  
material  
released

photo

Asphalt  
parking  
lot

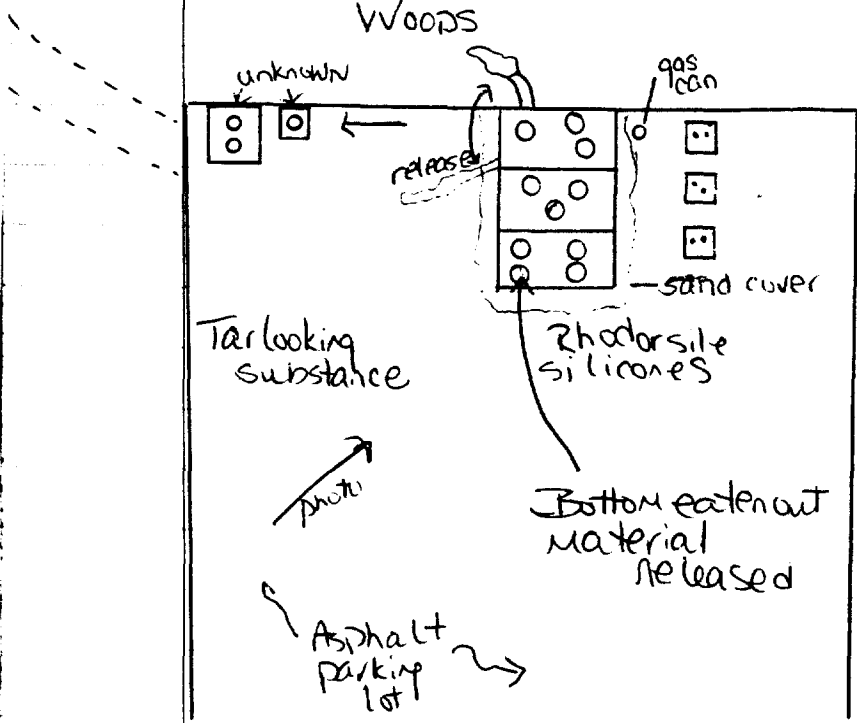

HP250-0/w  
2nd Marine  
Bldg. #P-250

B-25

11-17-93  
Roll 5  
Photo 29  
Rwm

oil/H2O Sep.  
Grate Top Rail on 2 sides

Bldg. -250

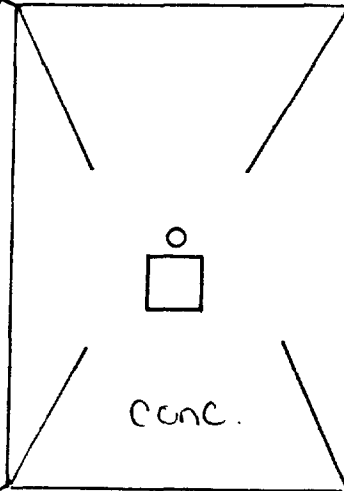
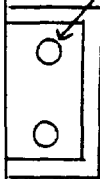

↑  
photo

WASH  
RACK

B-26

HP250-HWA HP250-AST

11-17-93

2nd Marine Motor T

Roll 5

Bldg. SHP-249

Photo 30

Bldg. 250.

Rwm

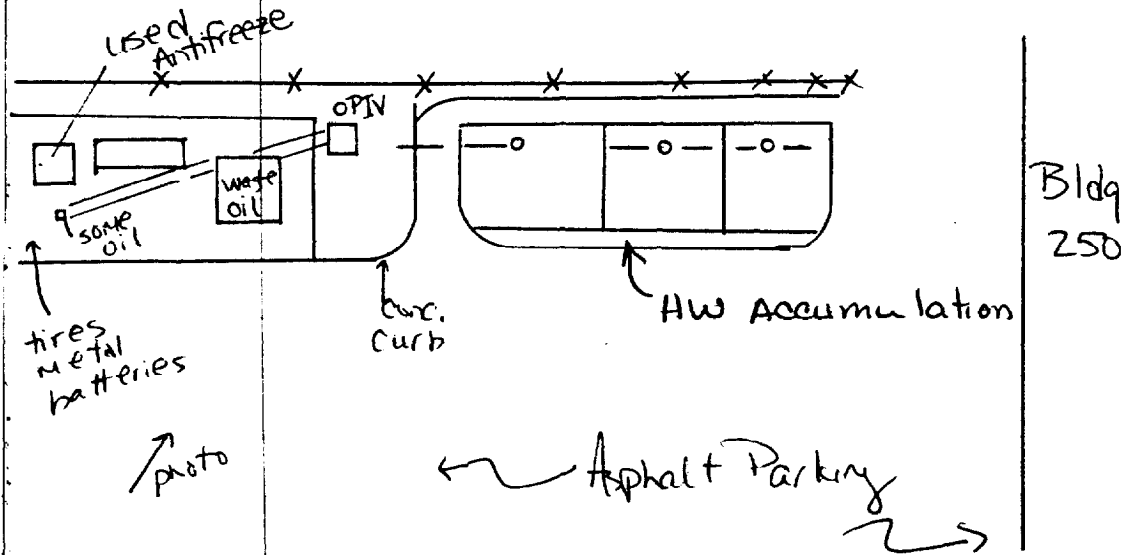



HP250-0/w  
2nd Marine 32nd  
Communication  
Bldg. 250

11-17-93 B-27

Roll 5  
Photo 31  
Rwm

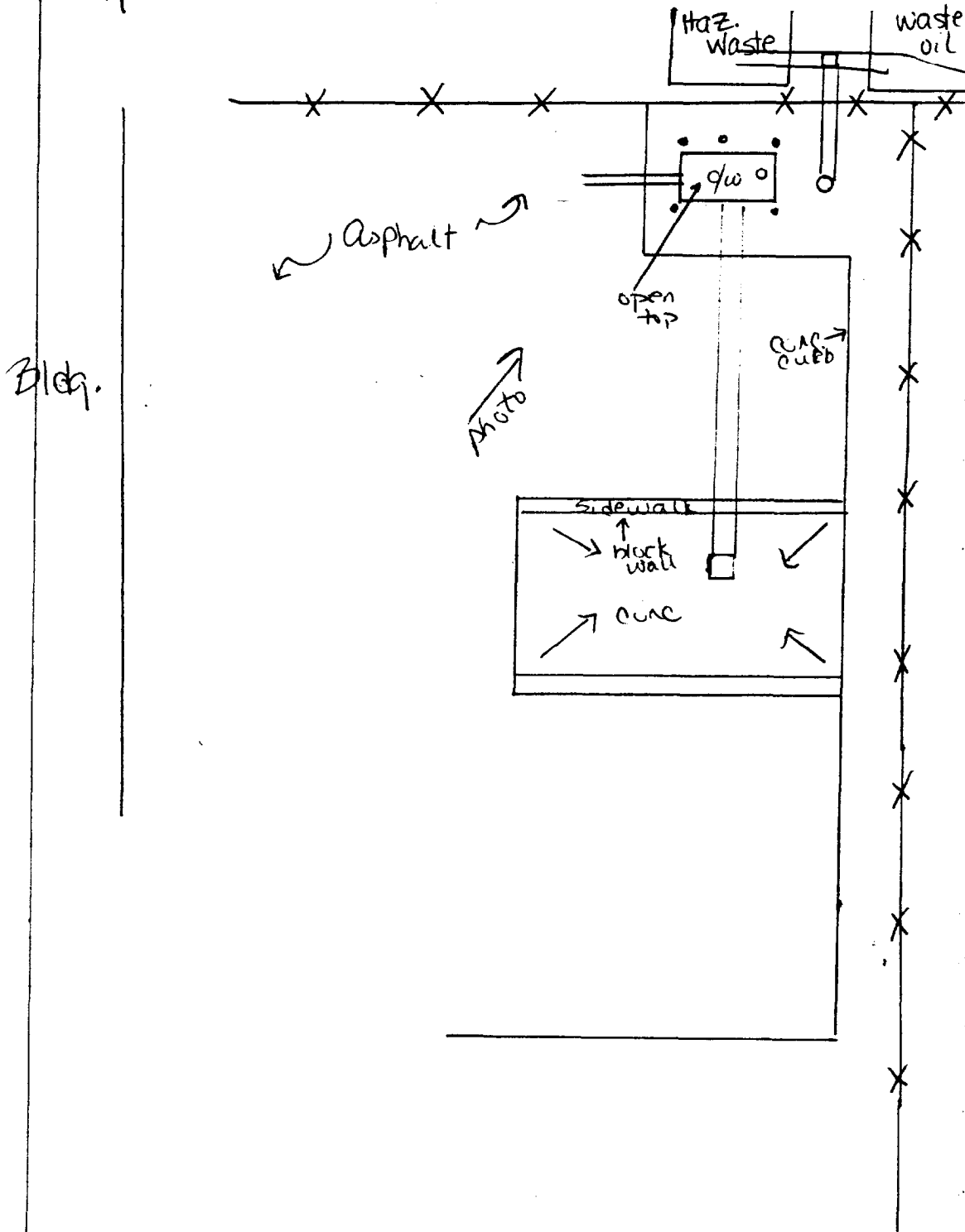

B-28

NH118-0/w  
Naval Hospital Public Works

11-17-93  
Roll 5  
Photo 32  
Rwm

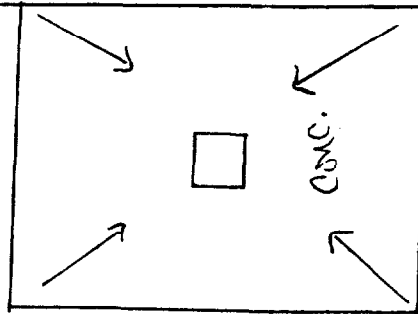
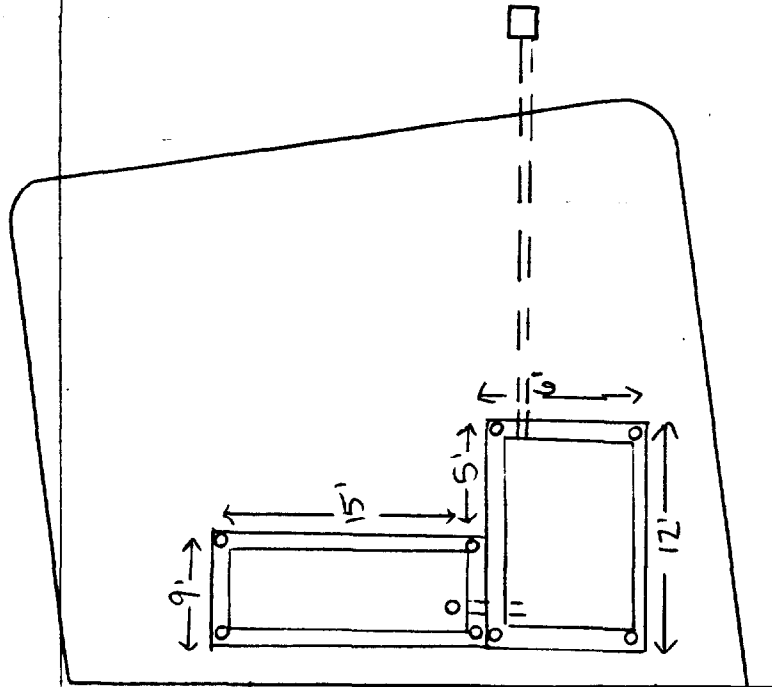

wash  
pad  
use soap

Photo

NH118-HWA  
Naval Hospital  
PW

11-17-93 B-29  
Roll 5  
Photo 33  
Room

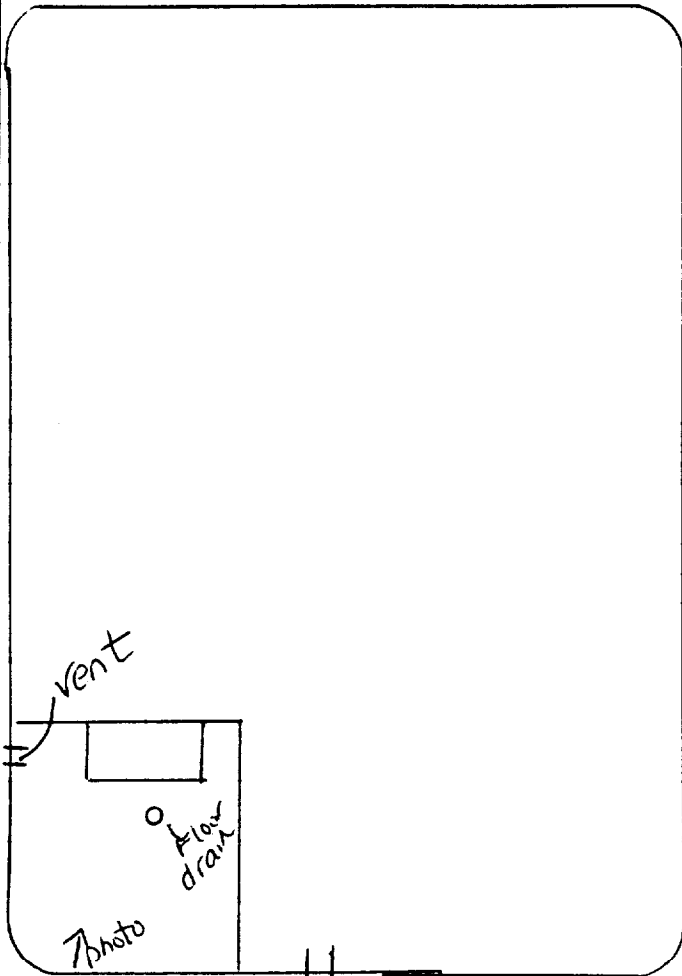

< 90 day

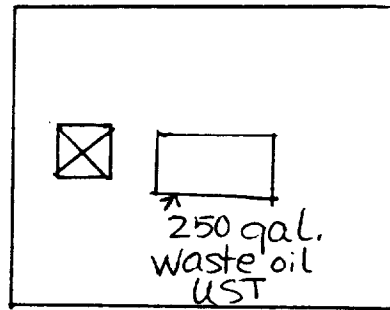

B-30

2615-0/w

BOQ

11-17-93

Rollis-Photo 3.1

Dwm

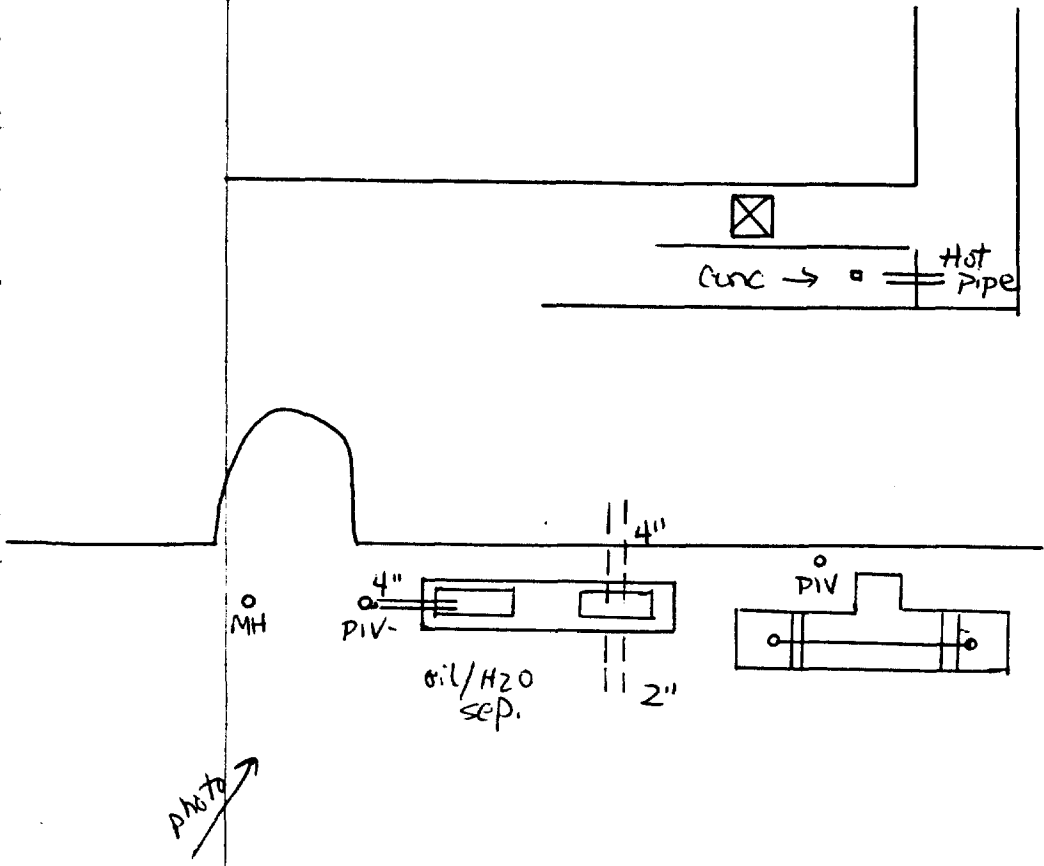

PT33-Pond-O/w PT33-Pile

B-31

Holding Ponds

11-17-93

Roll 5 Photos 35, 36  
Rwm

Animal  
shelter

Electrical lines

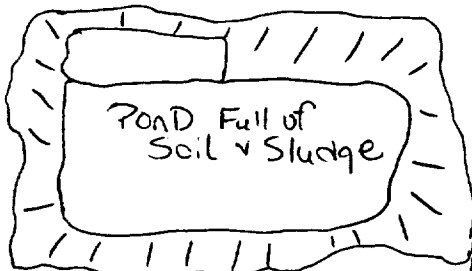

OM #

35  
Photo

36

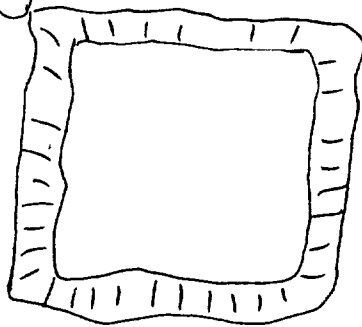

Multi-Chamber  
oil/H2O Sep.



Multi-Chamber  
oil/H2O  
sep

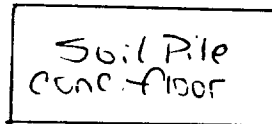

Parachute Road

To Holcomb  
Blvd.

B-32 908-HWA 908 Room  
 Logistic Bldg. - 980  
 Base Motor Transport  
 Body Shop

11-22-93  
 Roll Co-Photo 13  
 Room

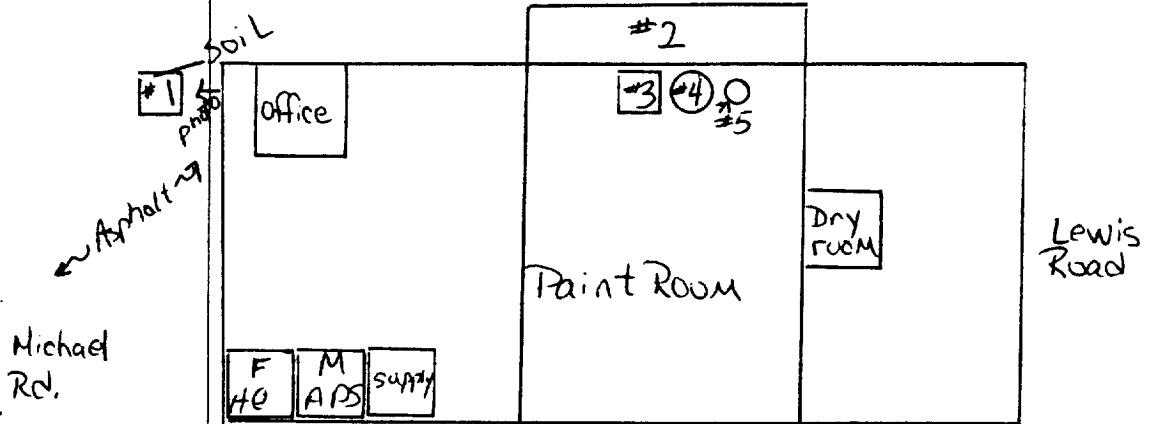

Metal Bldg. w/cement floor

Legend

1. 90 day storage site
2. Exhaust domes
3. Spray Gun Cleaner
4. Distiller
5. HW 30 gal container (SAA)

961-aw  
MCS Fuel Farm

B-33  
11-22-93  
Roller Photo 14  
Rum

ROAD

---

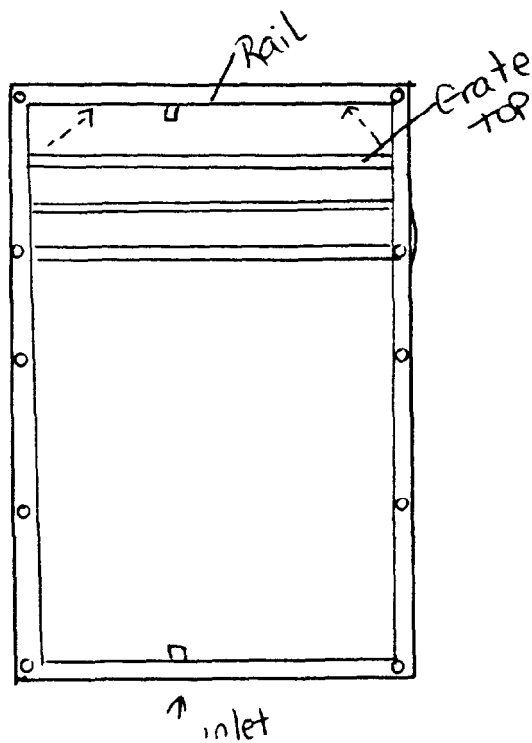

B 34 1407/1408-0/w  
Logistic 1408

11-22-93  
Roll 6-Photos  
Room

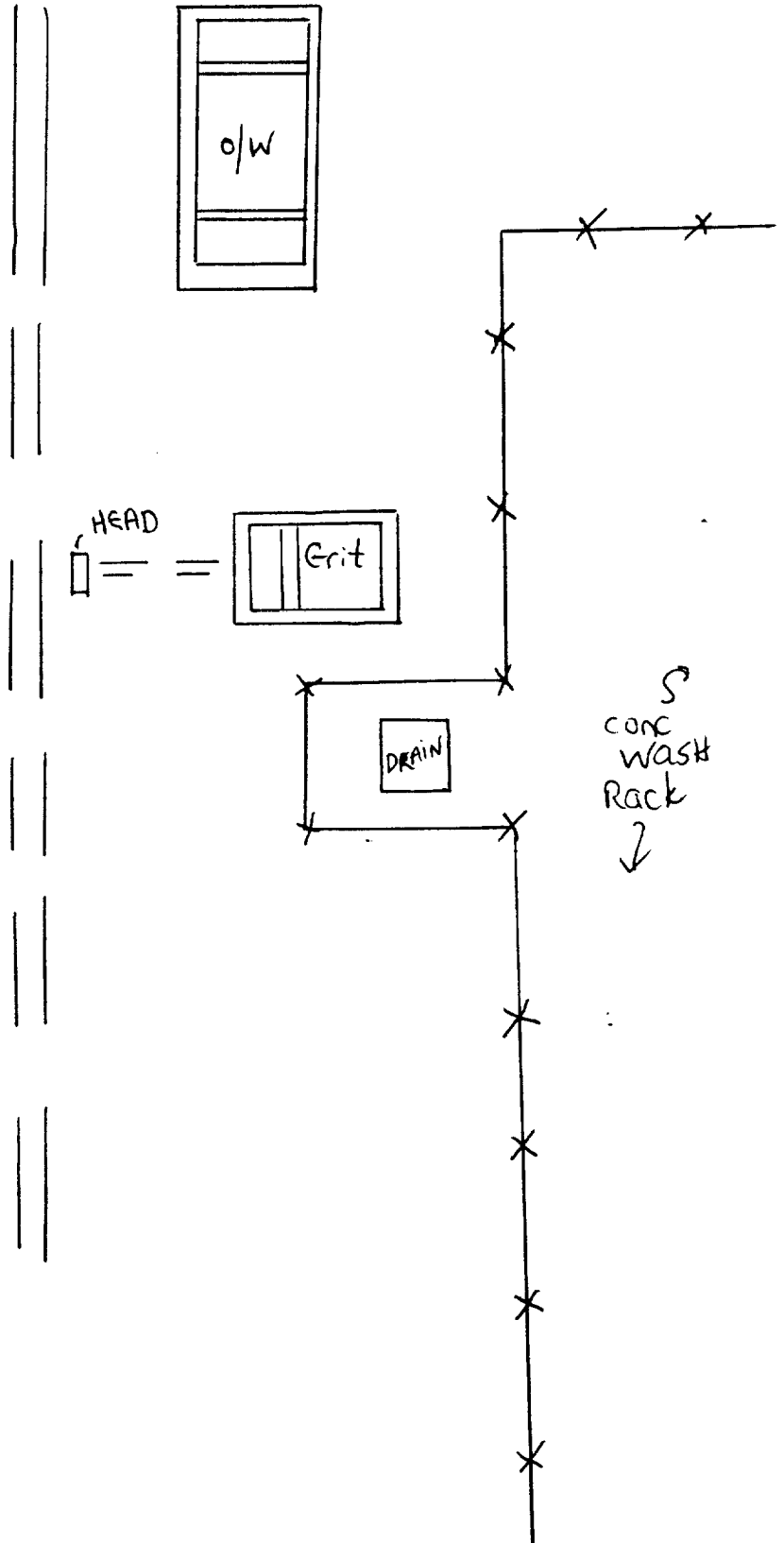



1502-o/w  
Logistic  
1502

B-35

11-22-93  
Rollie-Photo 16  
Rwm

RR

Elm

Road  
Gibb

Bldg 1502

grit  
chamber

o/w

-conc. flum

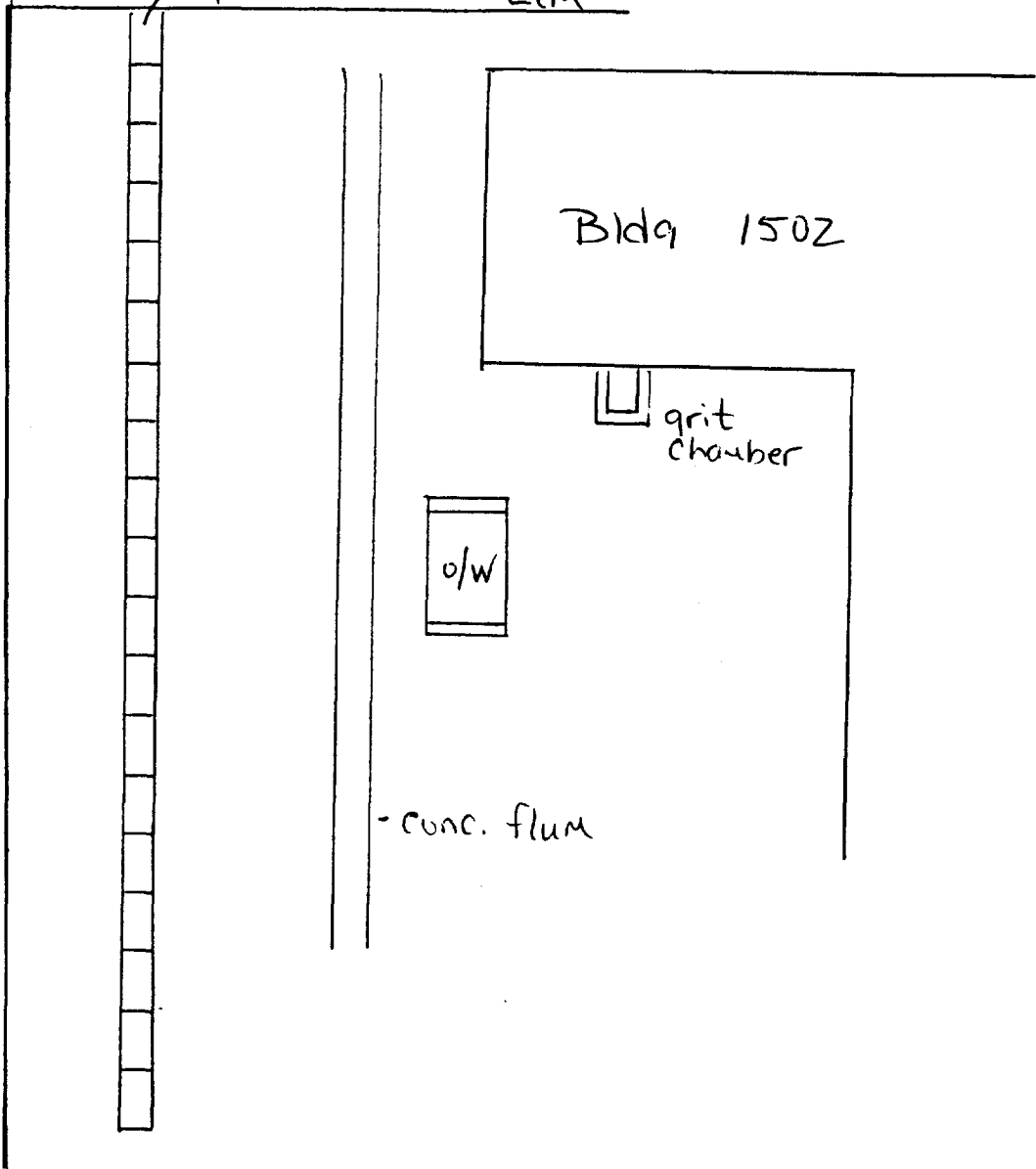

D-36

1502-0/w-2 1502-HWA

11-22-93

Logistic

Roll 6

Roll 6

Bldg. 1502

Photo 18

Photo 35

Rum

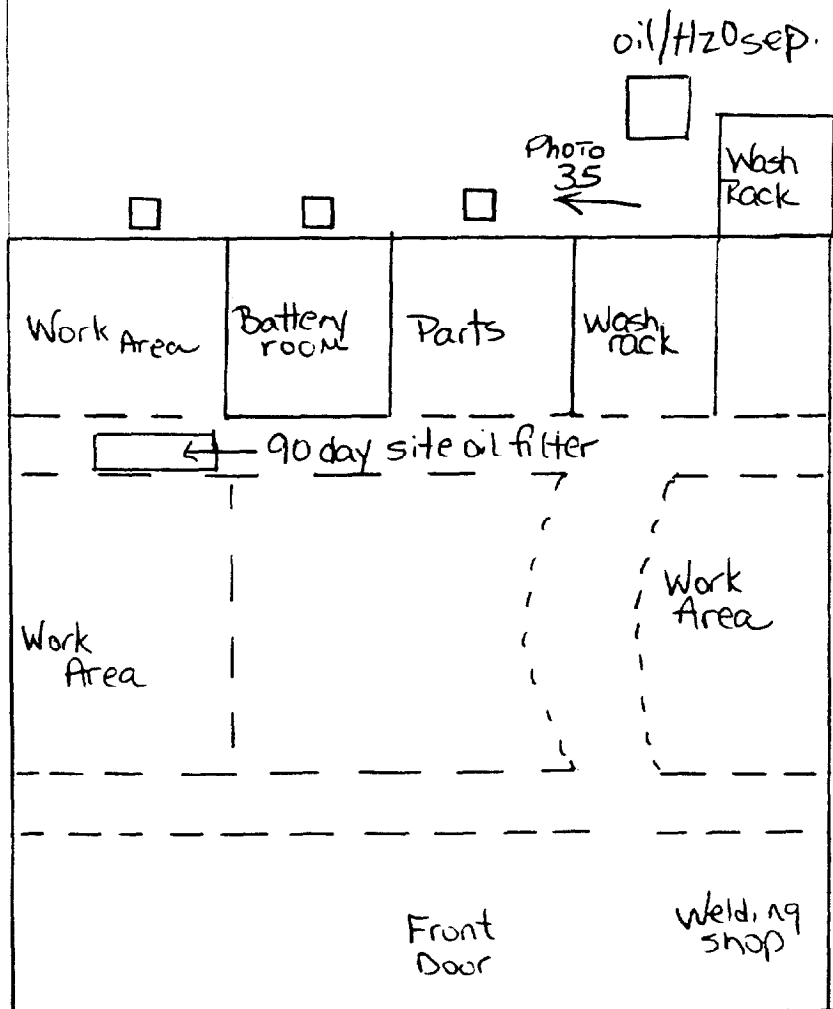

East St

TC-4-Basin  
Logistic Fuel  
TC 364

B-37

11-22-93  
Roll Co Photo 19  
Run

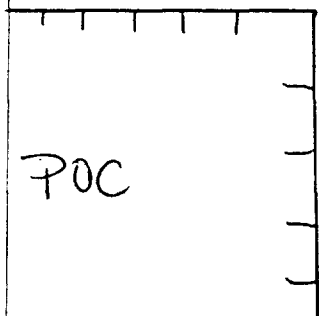
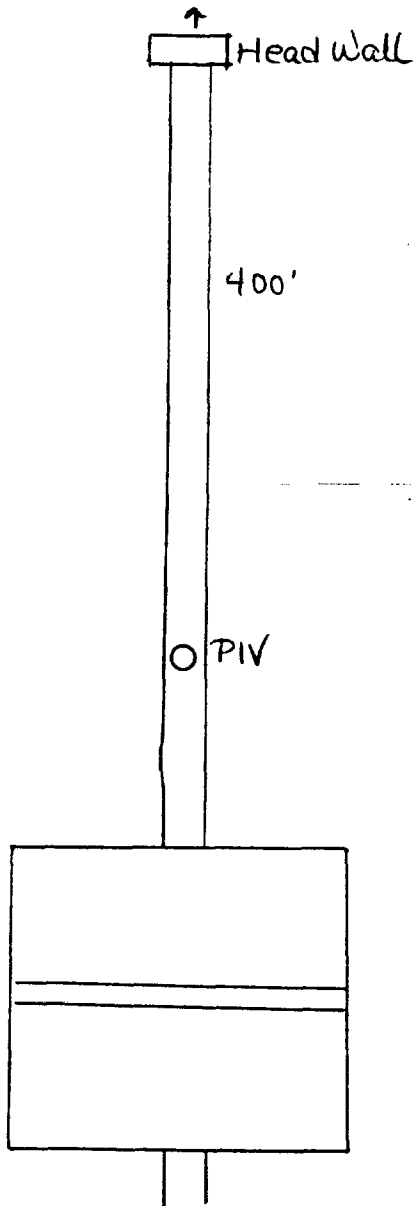

↑ photo

B-38

AS118-0/w

Logistic  
Air Station  
AS118

11-22-93

Roll 6 Photo 20  
Rwm

see Page B-109 - (Roll 6 - Photo 32 CB)

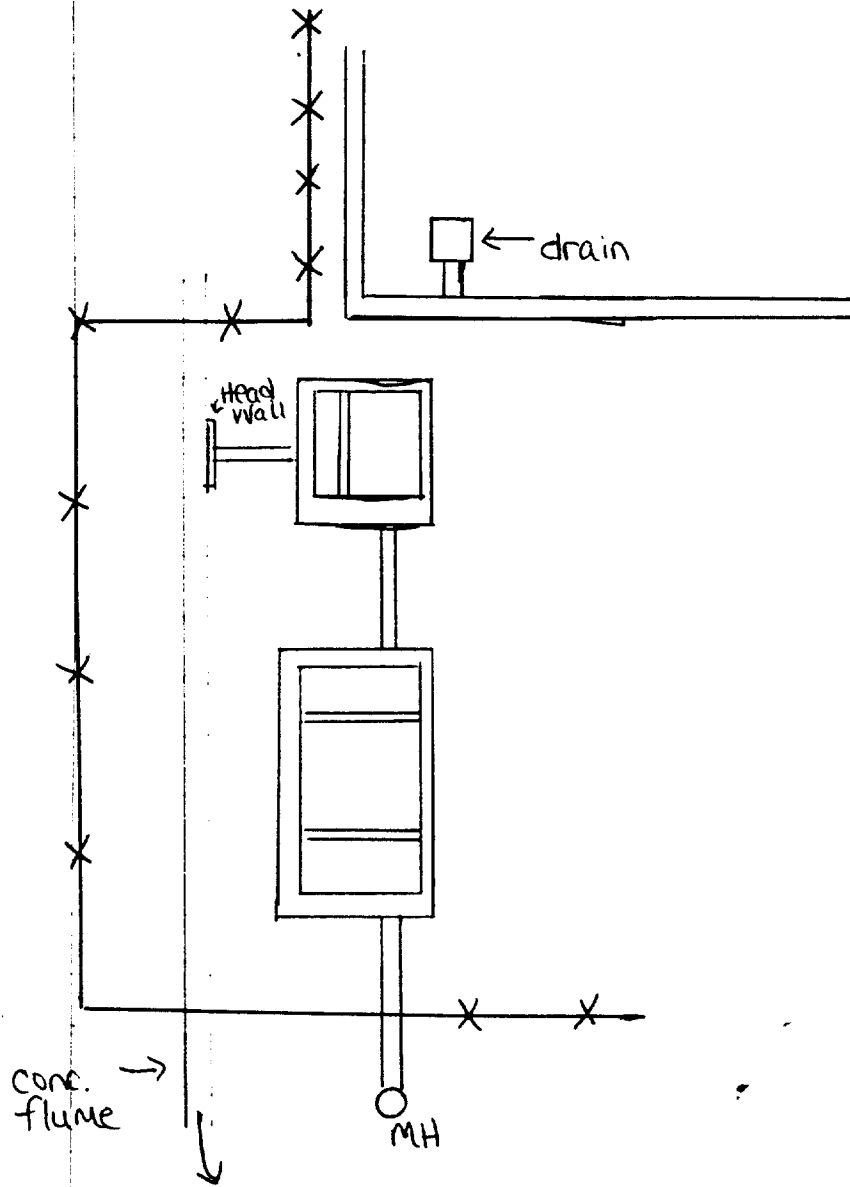

SA22-0/w

B- 39

SA-22

11-22-93

2nd AABn

Roll 6 Photos 21:22

Rwm/LB/cm

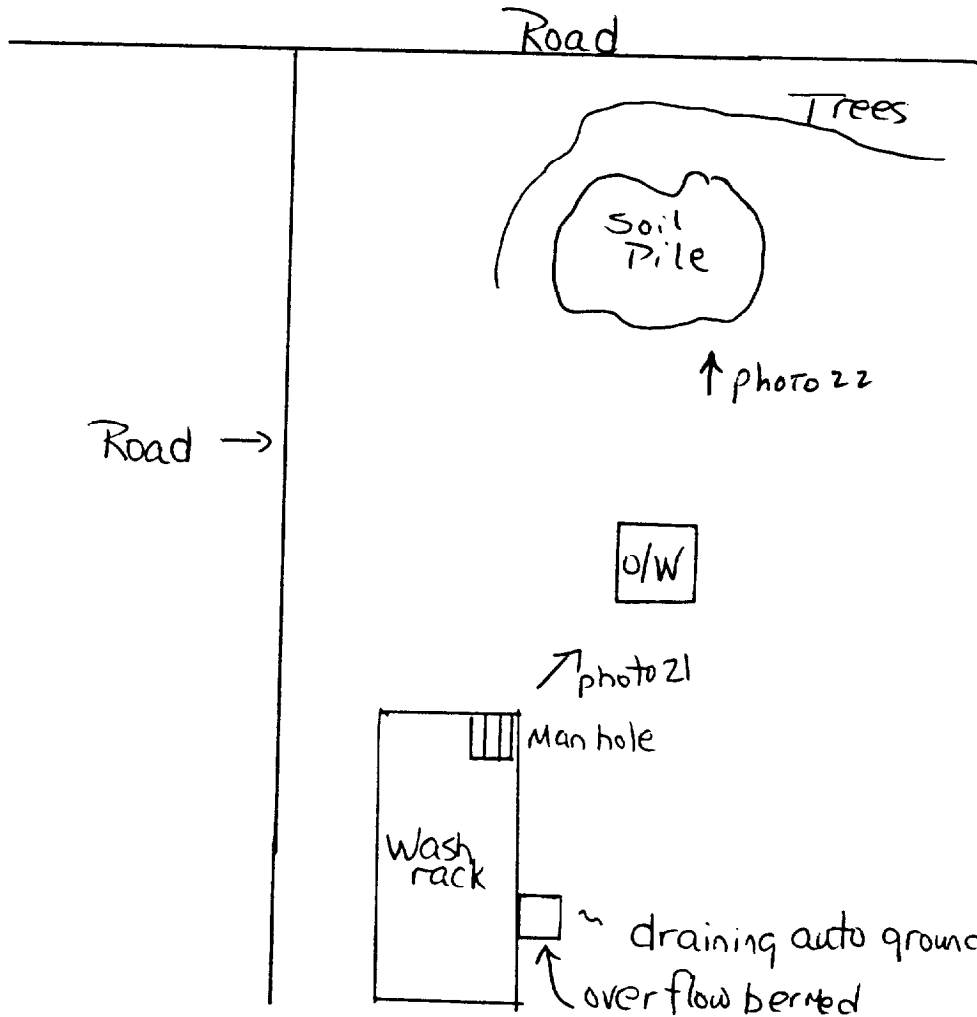

B-40

SA 22-Pile  
SA -22  
2nd AABn

11-22-93  
Roll 6 Photo 22  
Rwm/LB/cm

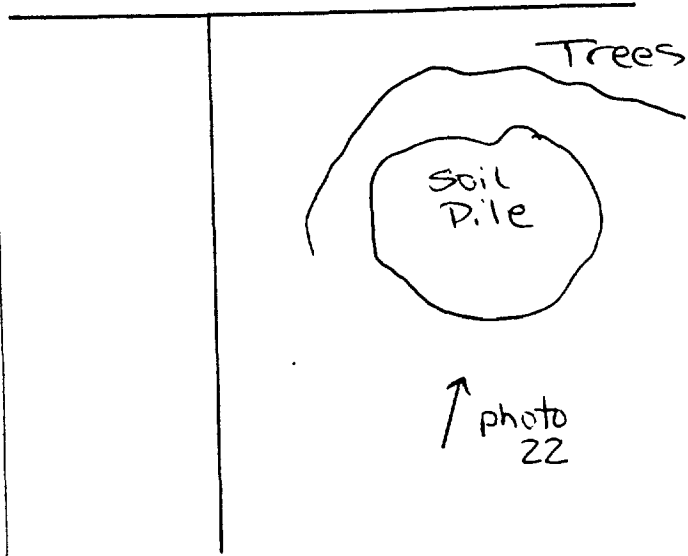

SA 10-0/w  
SA-16

B-41

11-22-93  
Roll 6 PHOTO 23  
RWM/LB/cm

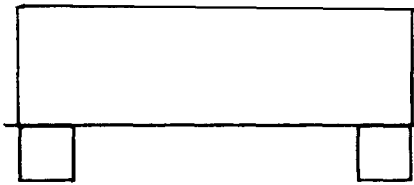
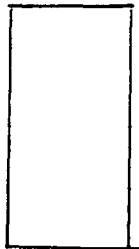
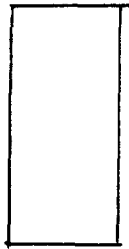
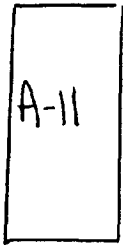

oil/H<sub>2</sub>O Sep.

← photo

□ MH

B-42

SA36-01w  
SA 36  
2nd AA Bn

11-22-93  
Roll 6 Photo 24  
Rwm/CB/cm

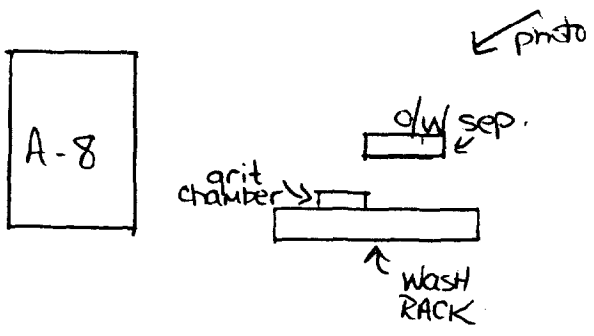



A1-HUSA  
Bldg. A-1  
2nd AA BN.

B-43

11-22-93

Rollie-Photo 25  
Rwm/LB/cm

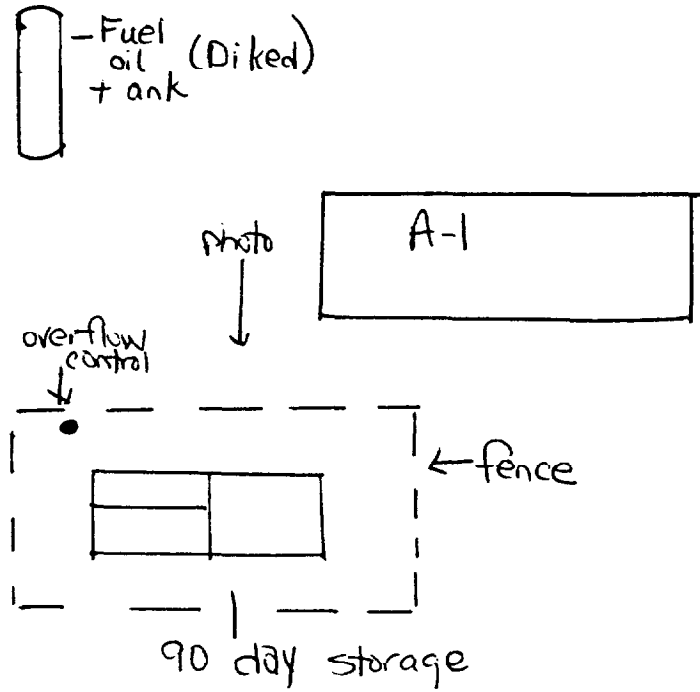

B-44

AI-Rack  
Wash Rack

11-22-93  
Roll 6 Photo 26  
Rwm/UB/CM

Bldg  
A-1

PIV

Basketball  
goal

conc →

↑  
photo

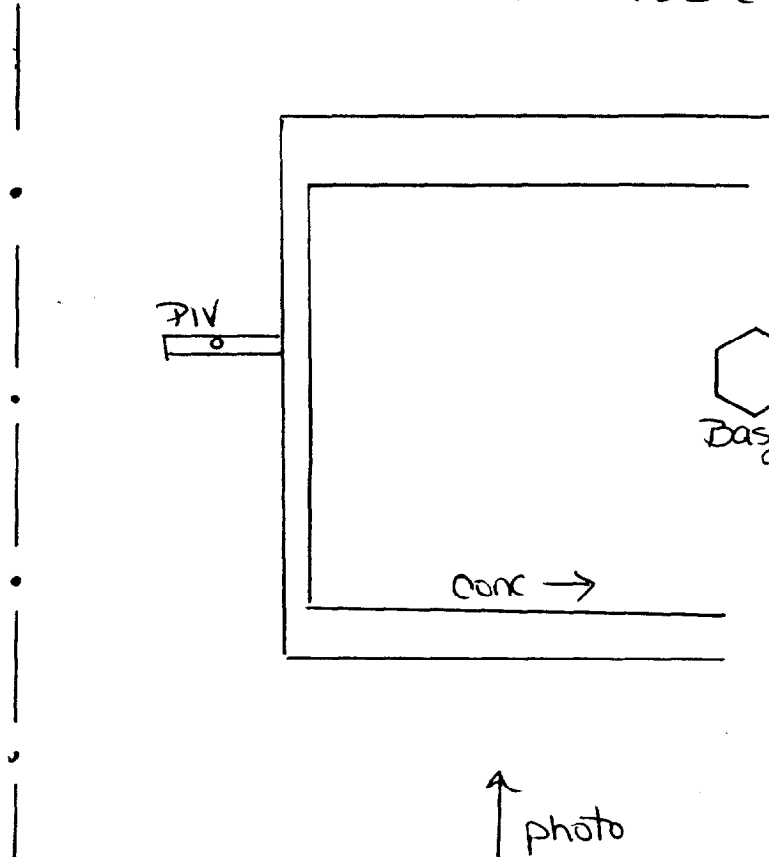

ST32-Pile  
Construction Debris  
Tarawa Terrace  
ST32-pile

11-23-93 B-45  
Roll 6 Photo 28  
Burn

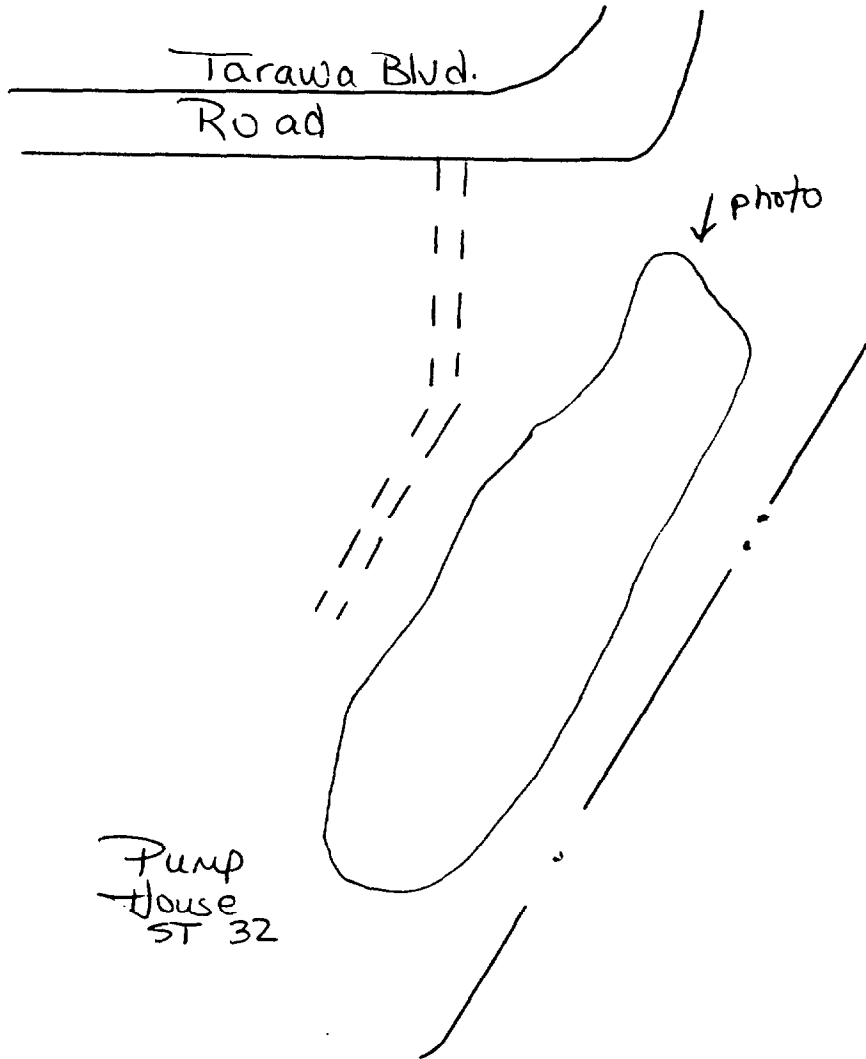

B-46

TT2453-AST TT2453-HWA  
Auto Hobby Shop TT 2453  
Tarwa Terrace

11-23-93  
Rollie Photo 29  
Room

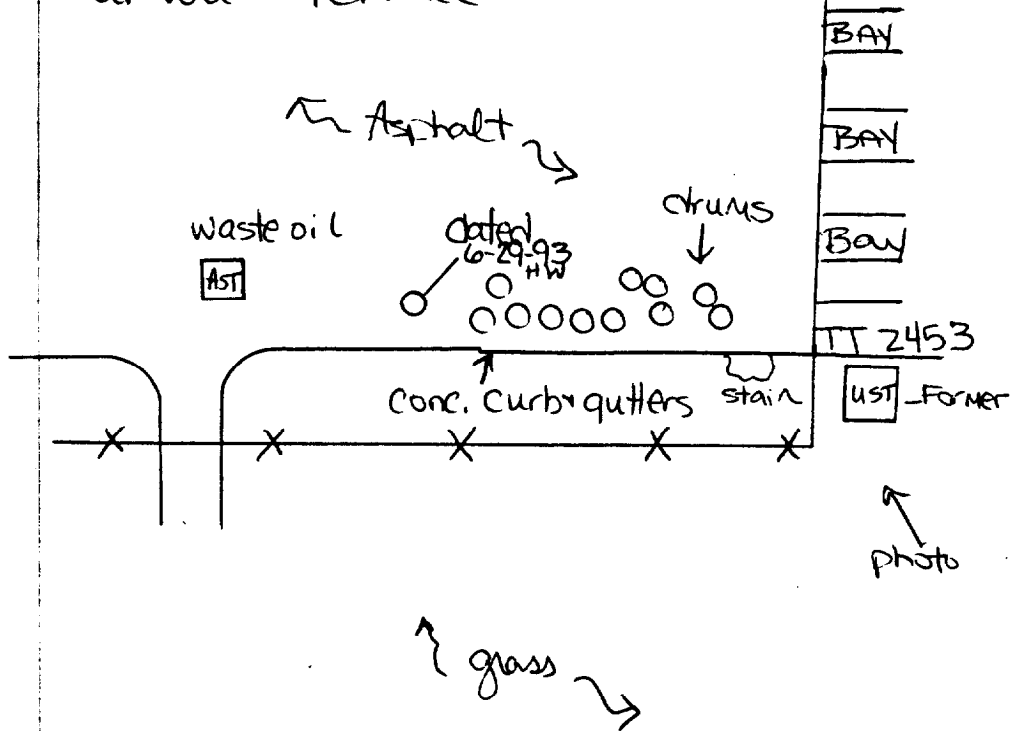

BA130-0/w BA130-AST 11-23-93 B-47  
Recon Motor T BA130 0/w/AST  
Roll to Photo 30  
Room

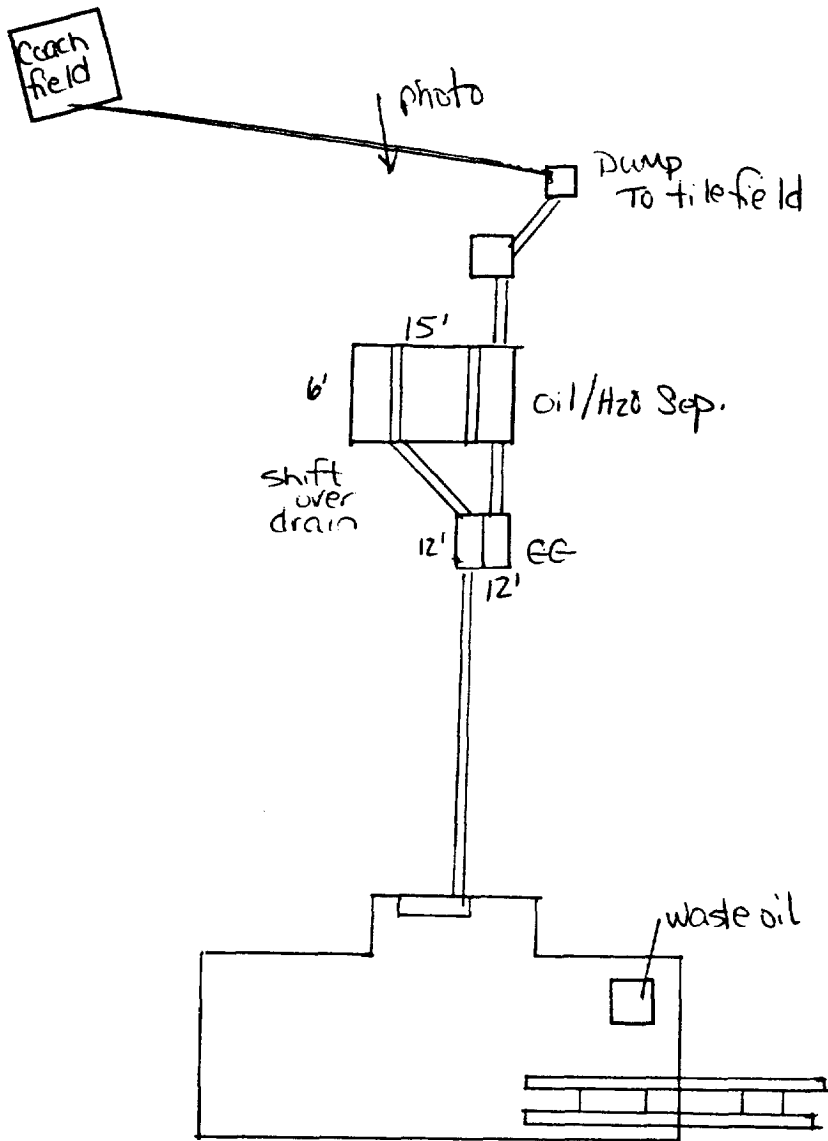

B-49

BA130-HWA  
Recon BA130-HWA  
<90

11-23-93  
Roll 6  
Photo 31  
Room

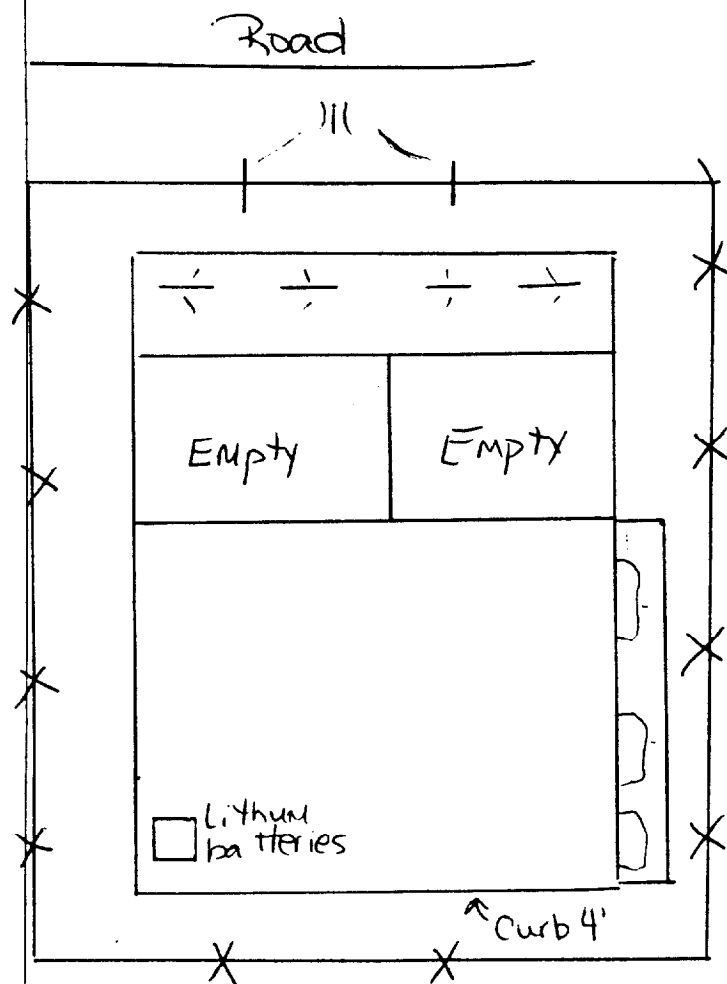

← photo

1053 - o/w  
Bldg. 1053  
MWR Car Wash

11-23-53<sup>B-49</sup>  
Roll 6  
Photo 32  
Rwm

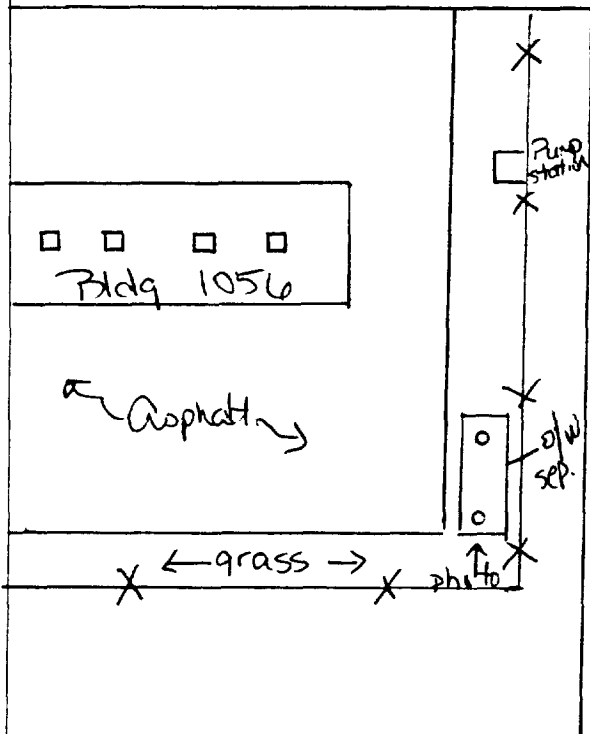

↓  
Holcomb  
Blvd.

3-50

S1001-BASIN

11-23-93

S1001

Roll 6

Containment Basin  
Spill Containment

Photo 33

Rum

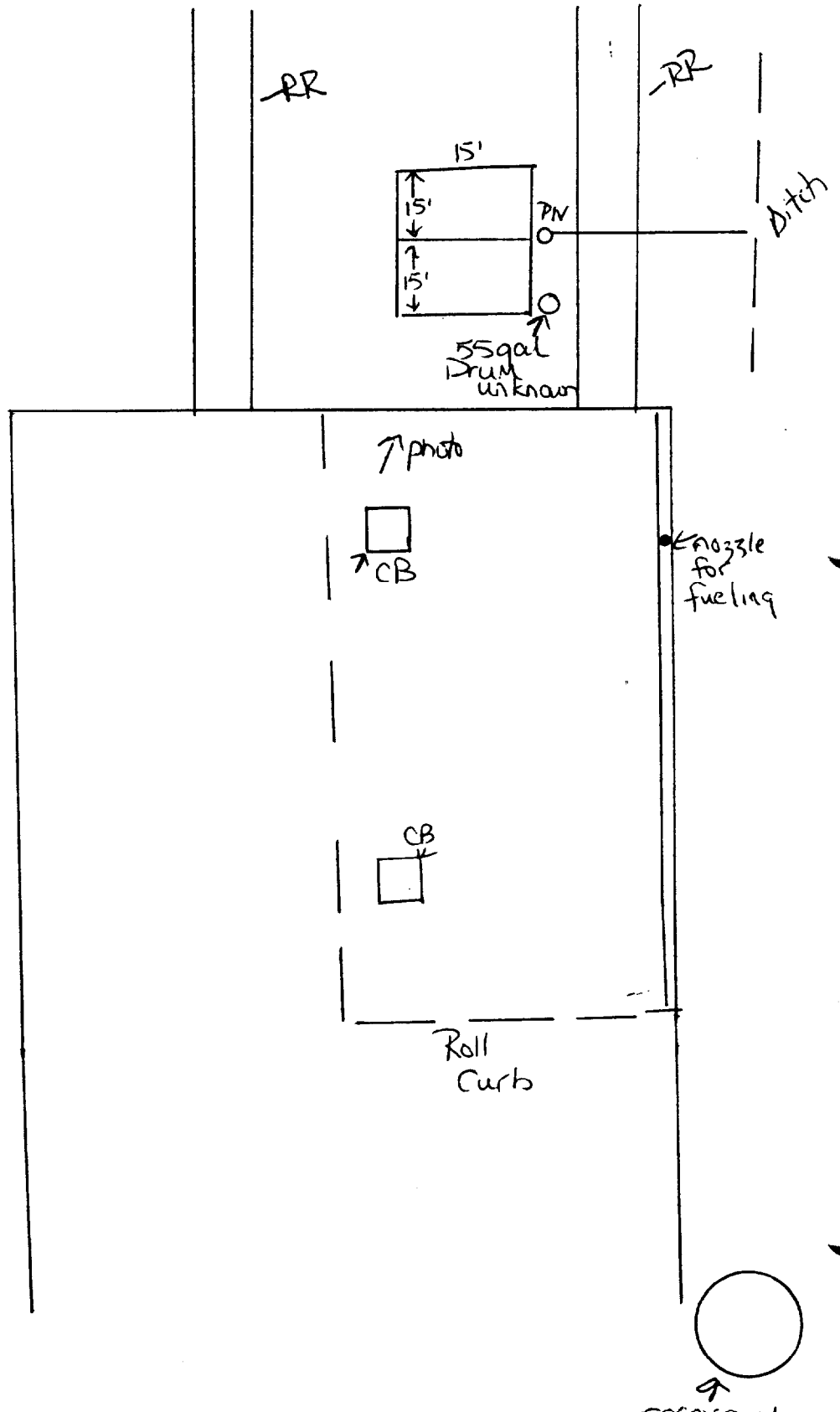



S1132-0/W  
Bldg. S1132  
SDB & 0/W

Roll 23-93 B51  
Roll 6  
Photo 34  
Room

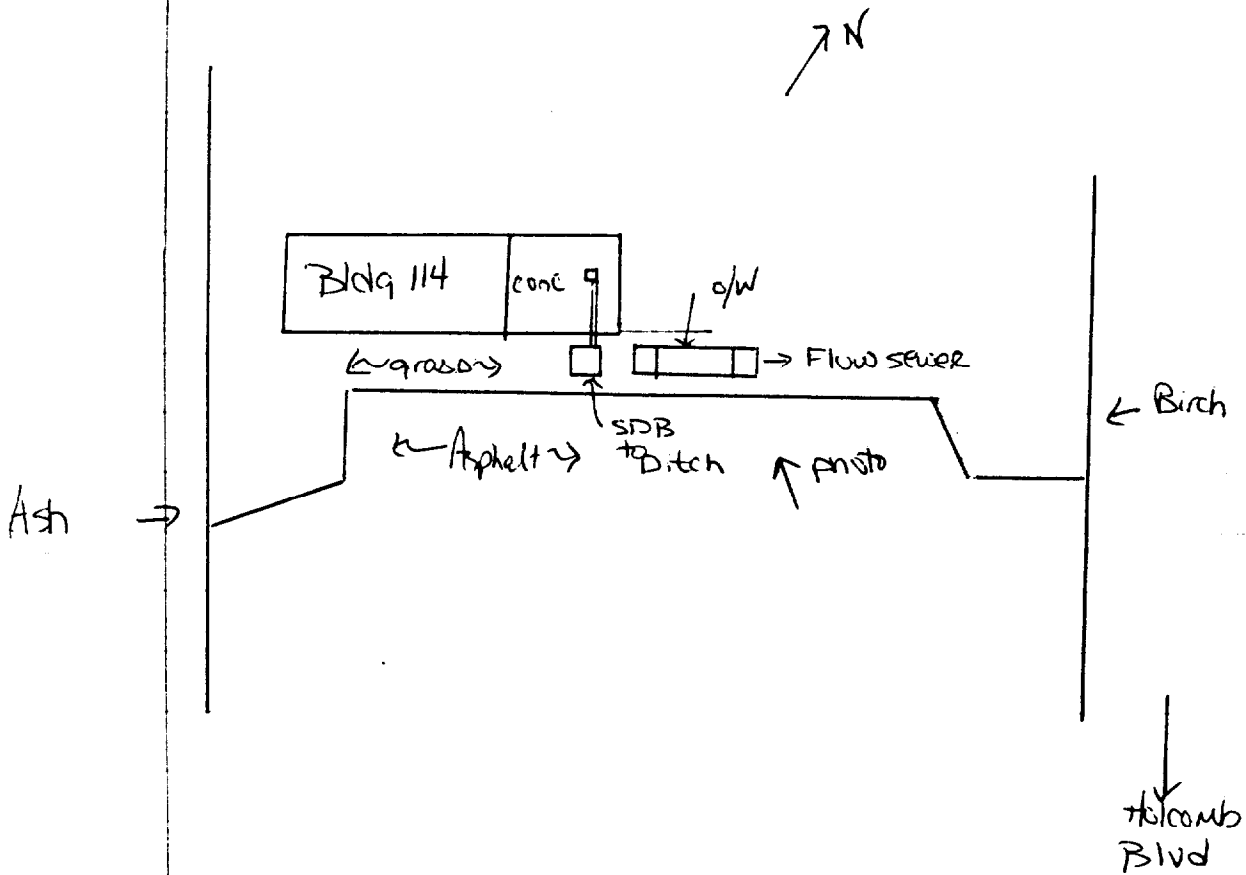

B-52 11610-01/w  
Base Auto shop

11-23-93  
Roll 6  
Photo 36 & 37  
Rwm

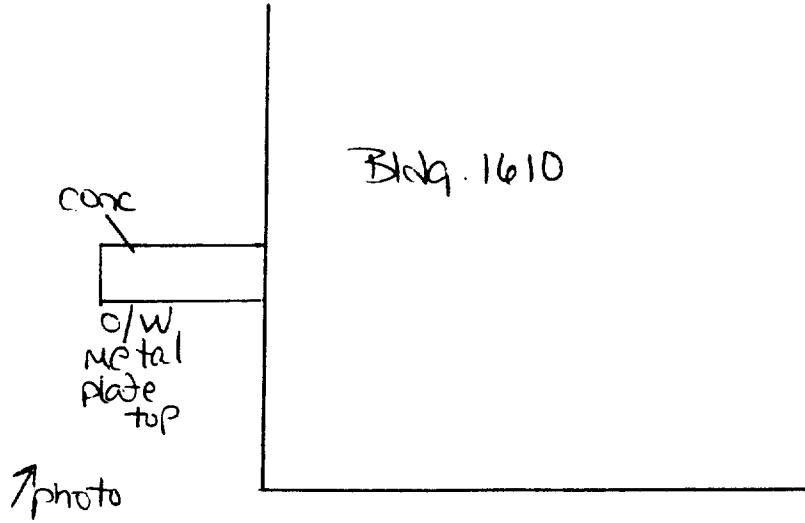

575-01W 575-HWA 575-AST-575-<sup>B-53</sup>LIST  
 Bldg. 575 12-06-93  
 <90 day Roll-7 (No Photo)  
 Rwm/LB

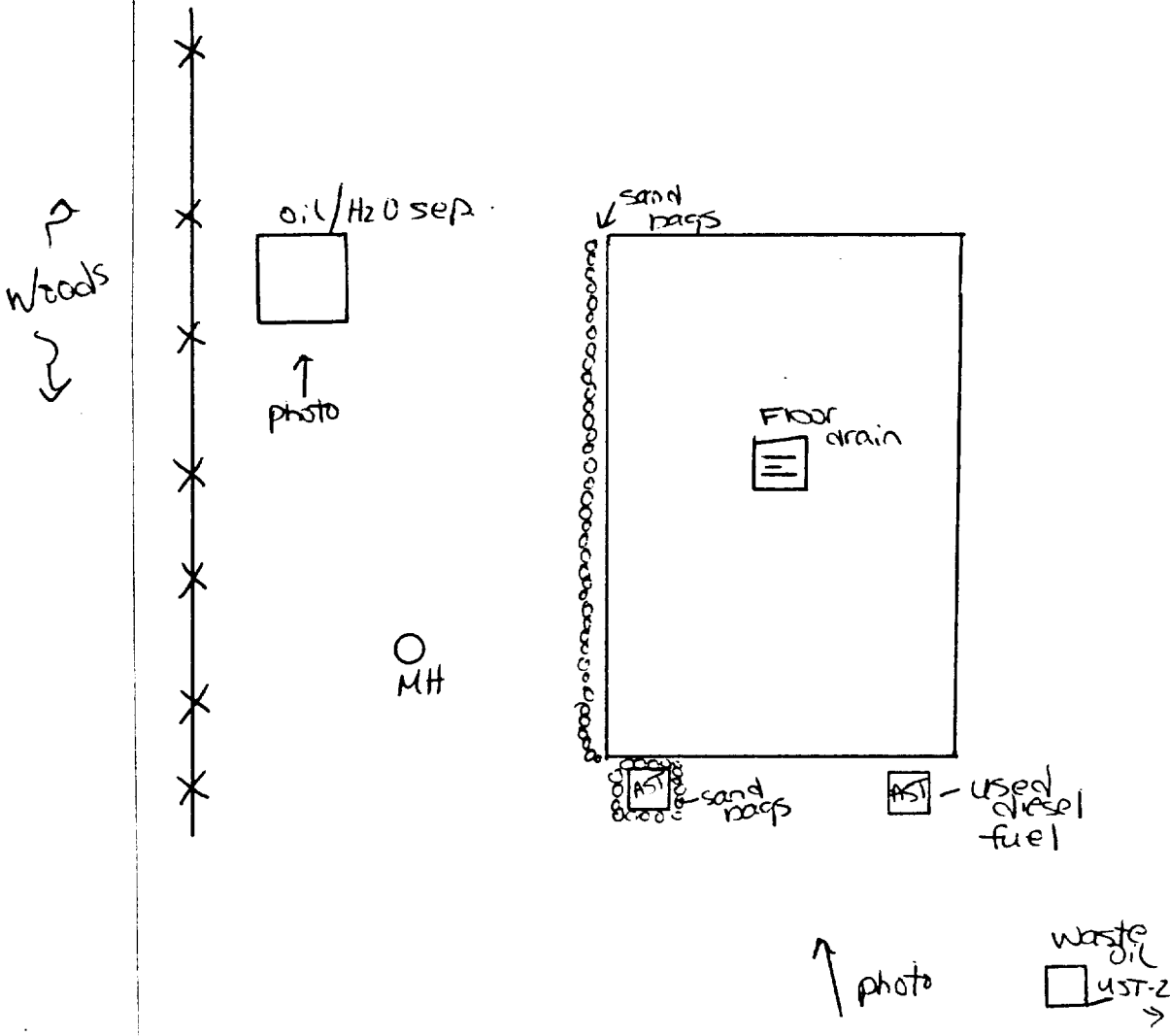

note: Photos Taken but did Not  
 Come out (Ru)

Bldg. -575

B-54

575-RACK  
Bldg. 575

12-00-93

Roll 7 - (No Photo)

Rwm/LB

Wetland



← Photo

WASH RACK

Bldg.  
575

Note: Photo taken but did not come out

Rw

540-Backwash  
Area 5

12-06-93 B 55  
Roll 7 Photo 2  
Rwm/LB

Bldg. 540 - Backwash

River Road

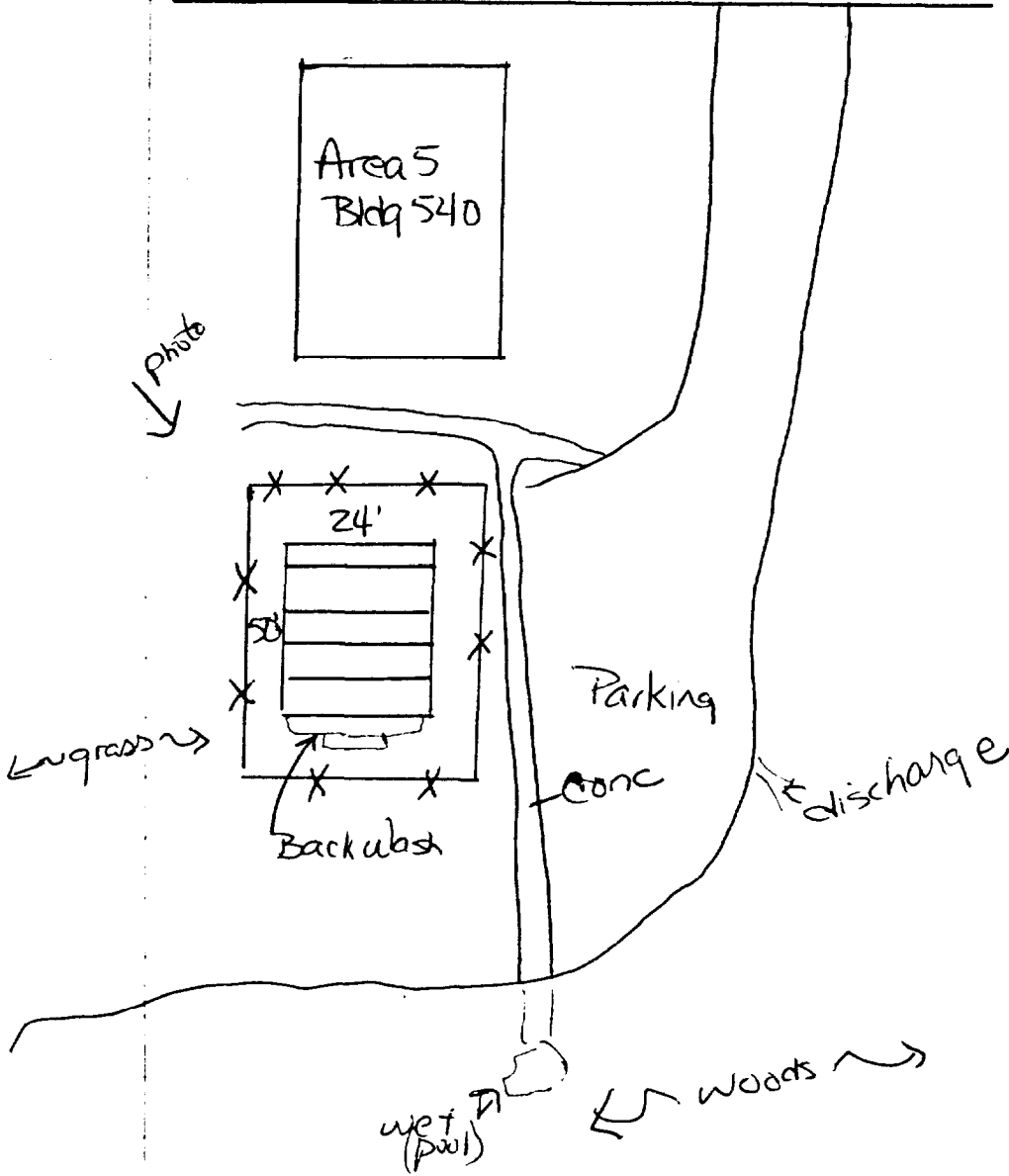

B-56

236-Backwash  
Bldg. 236  
Backwash basin

12-06-93  
Roll 7 Photo 3  
LB/Rwm

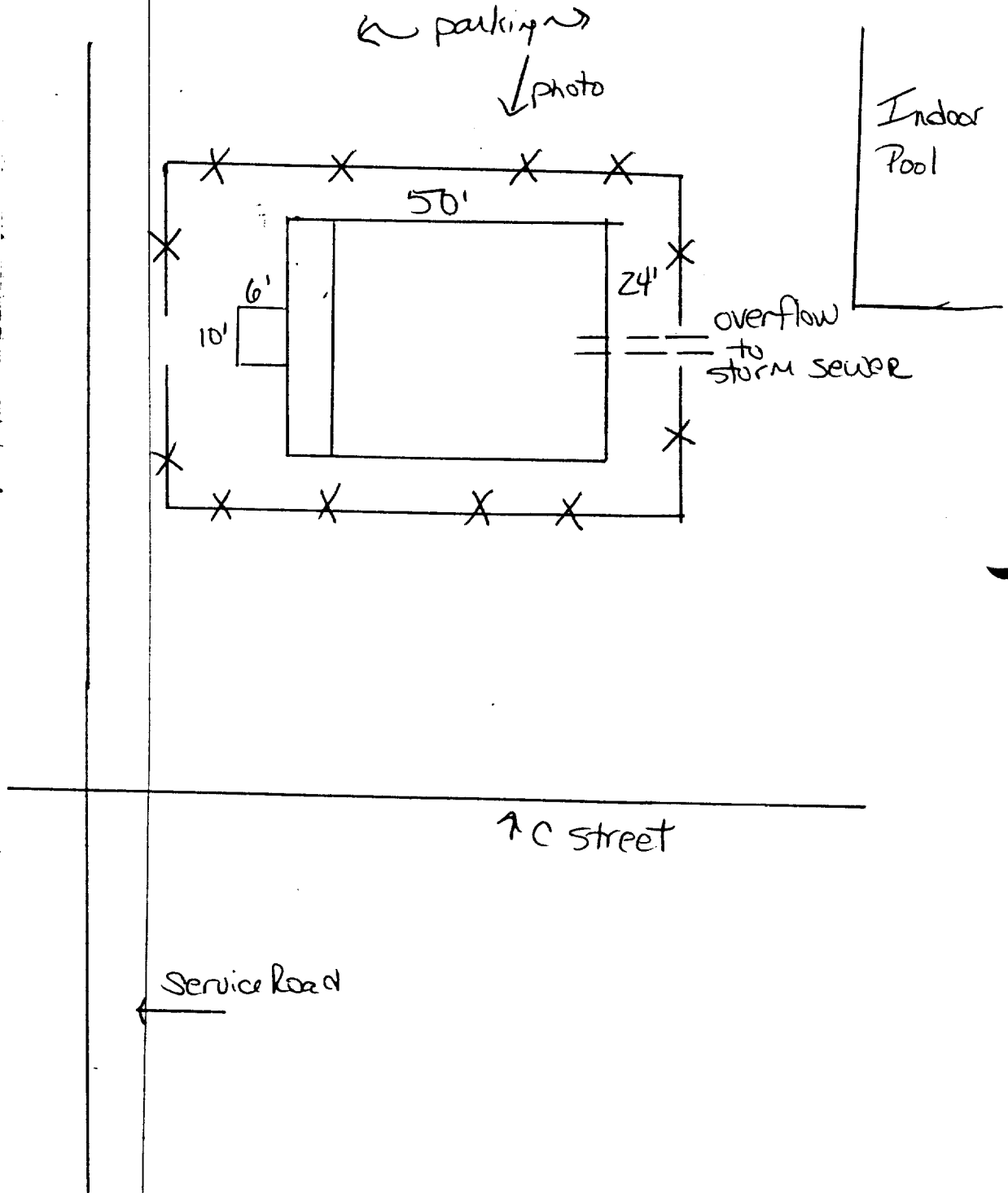

25-0/w  
Bldg. 25 Cleaners

12-06-93<sup>B 57</sup>  
Roll 7 Photo 4  
Rwm/UB

9 USTS

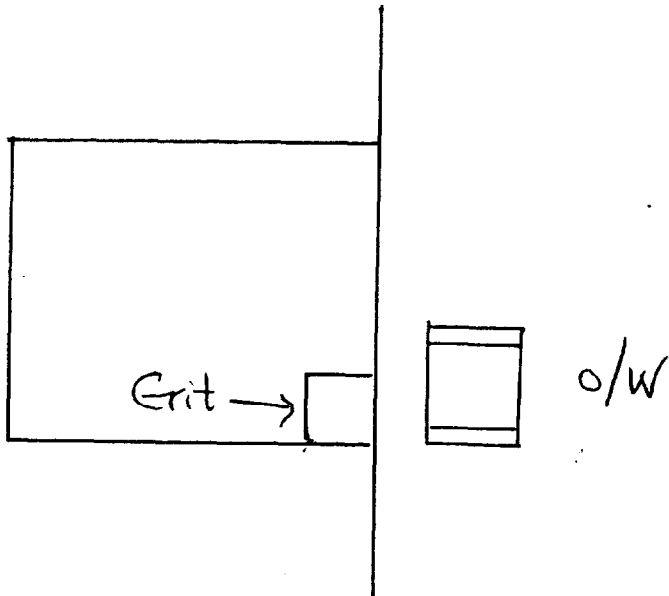

B-58

43-AST  
Police Washing  
43-AST

12/06-93  
Roll 7 Photo 5  
Rwm/LB

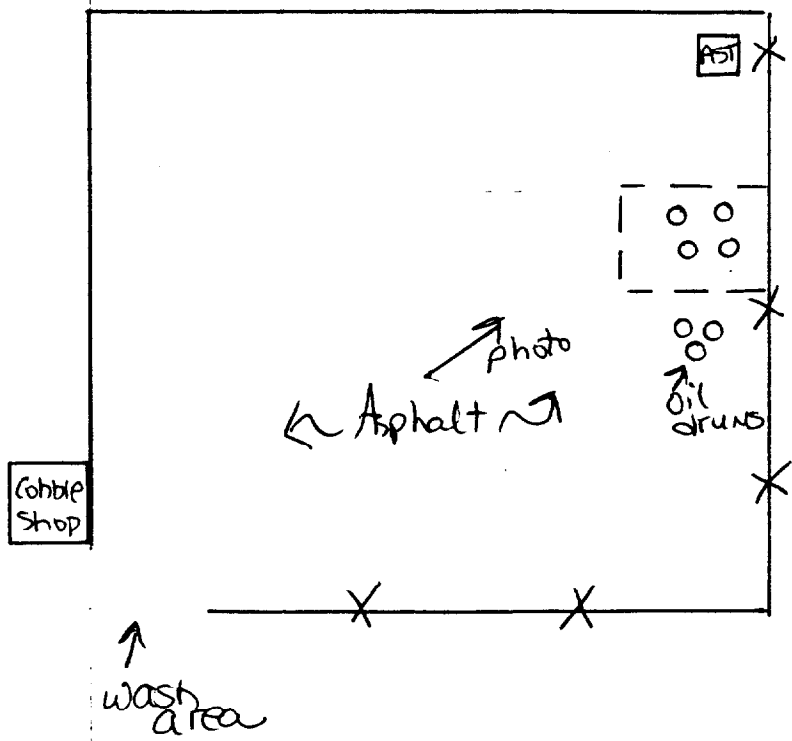



1014-Container  
Former PCB Yard  
Near Ash Road  
1014-Container

1207-93 B-59  
RDU 7 Photos 6:7

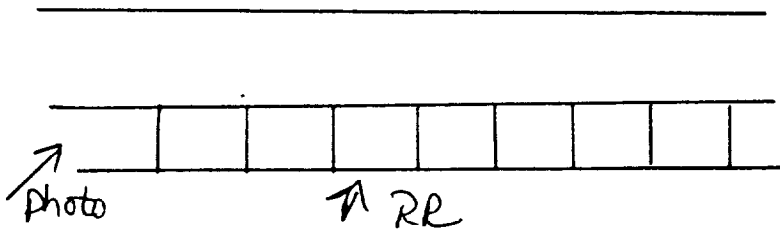
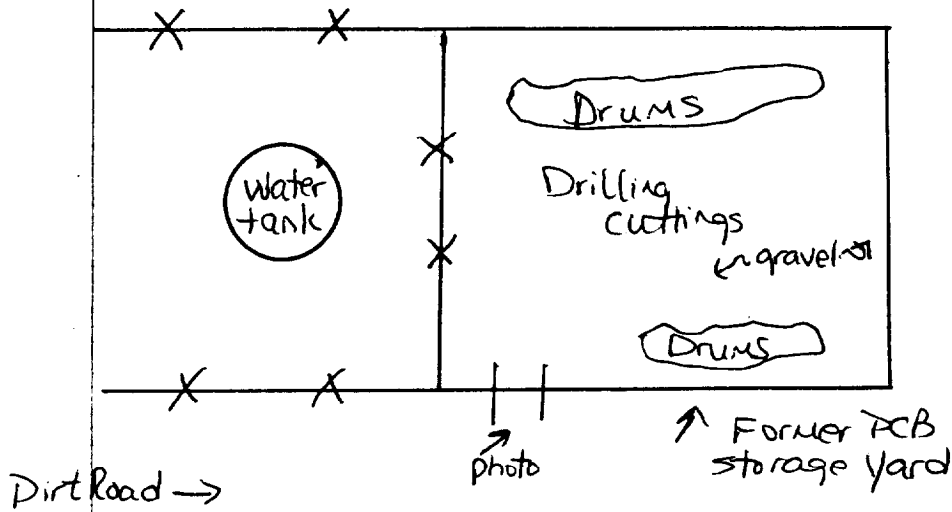

B-60

S946-UST  
Grease Rack  
S946-UST

1207-93  
Roll 7 photo 13

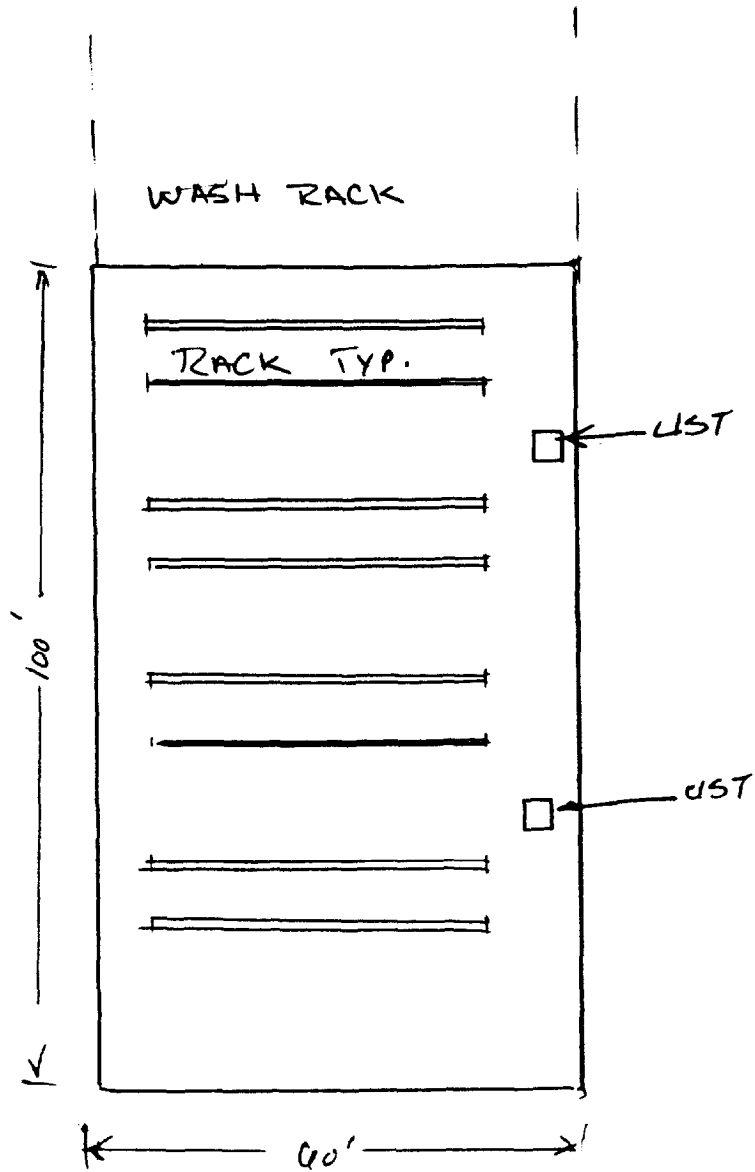

S947-Pile  
Soil Pile  
S947-Pile

12-07-93 B-61  
Roll 7, Photos 8, 9, 10  
; PHOTO 12

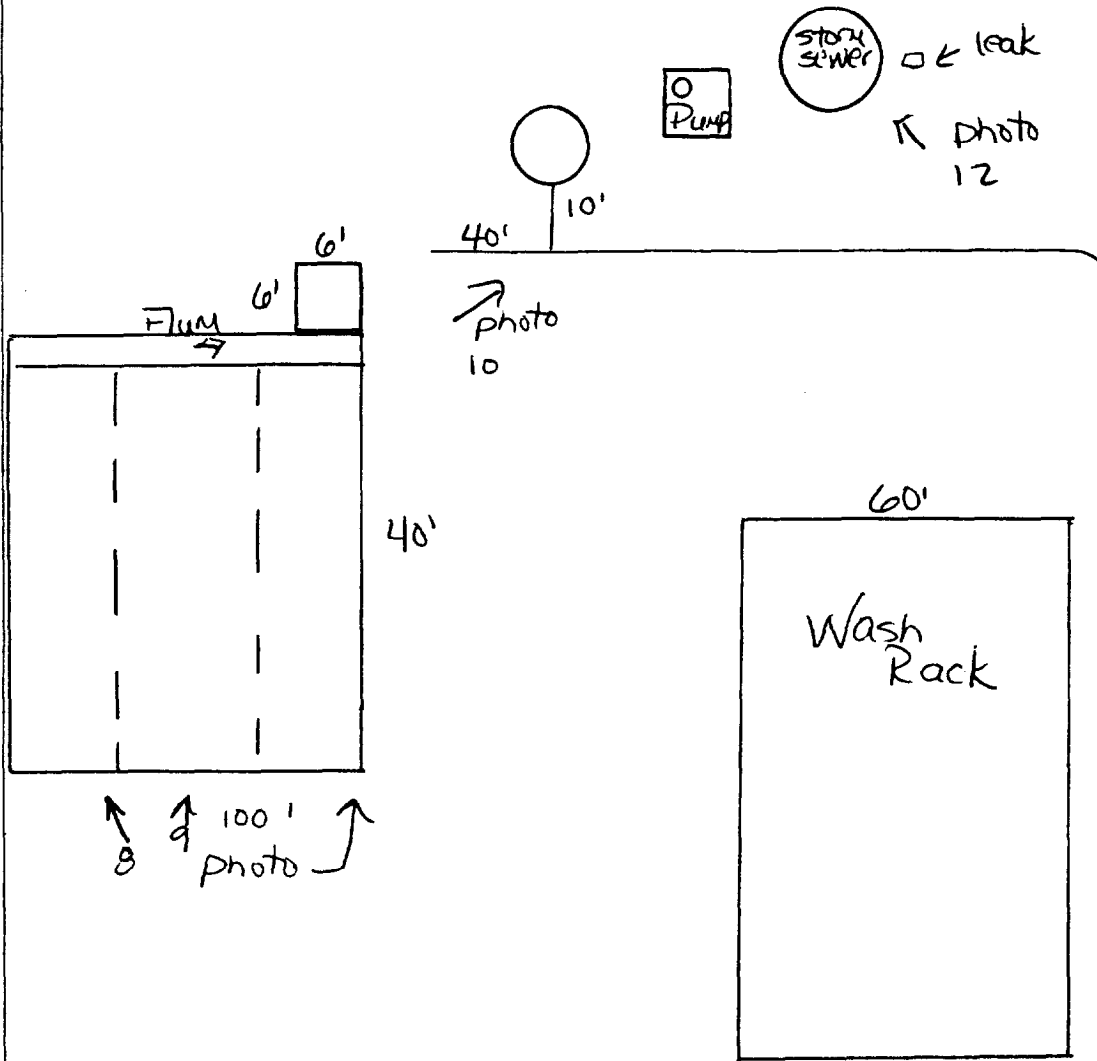

Michael Street

Bun

S947-0/w

12-07-93

Wash Rack

No Photo

Oil/Water Sep.

See Photo 11; 13 Rom

S947-0/w

↑ TO Oil/Water Separation  
See page 6

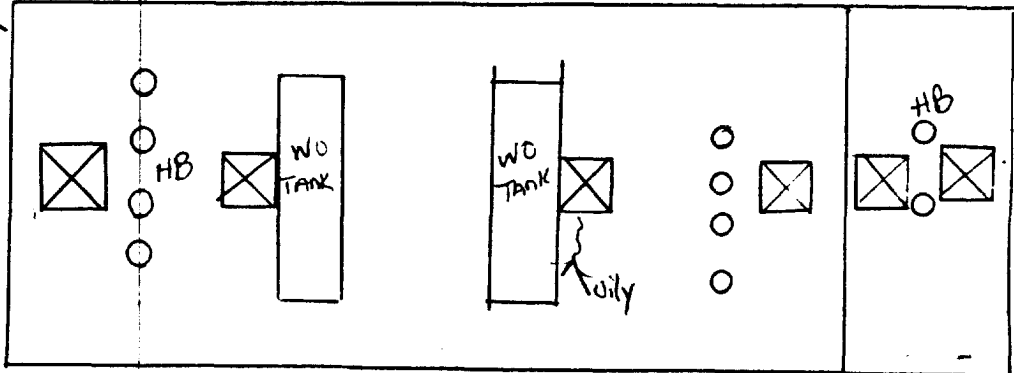

S946-AST  
Waste Oil AST  
S946-AST

12-07-93 B-63  
Roll 7 Photo 11

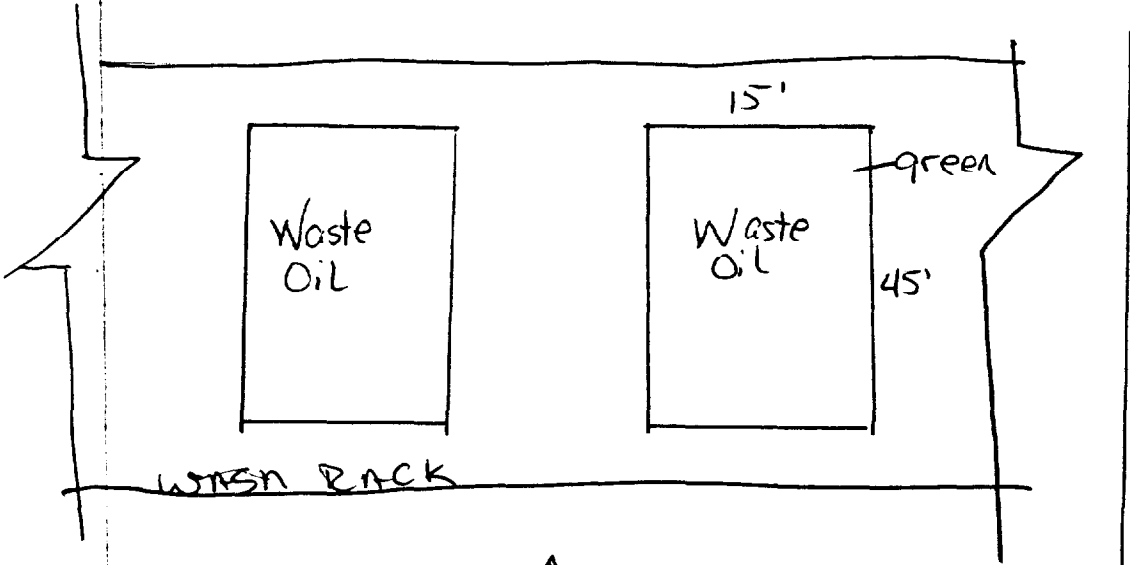

↑ photo

→  
Michael  
Street

B 6d

S947-Container  
Soil Contaminated w/POL  
Bldg S947 (near)  
S947- Container  
(See Page 61)

12-07-93  
Roll 7 Photos

Roll-offs are staged for  
off site shipment  
Roll-offs 30 cubic Yards

913AST  
Recycling Center  
Bldg 913-AST

12-07-93 B-65  
Roll 7 Photo 15

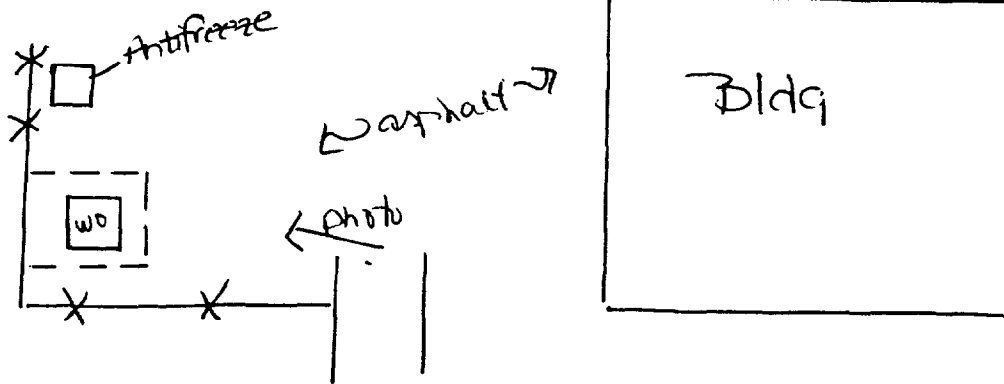

Michael<sup>↑</sup> Street

B 44

TP45-AST

12-07-93

Traffic Driving School

Roll 7 photo 18

TP 45-AST

Bldg 45

photo →

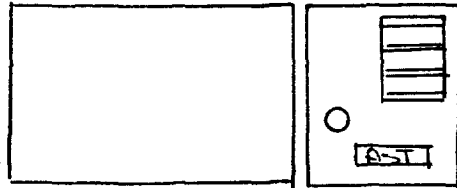



TP45-Rack

12-07-93 B-67

Wash Rack TP45-WASH

Roll 7-Photo 19

Truck Driving School

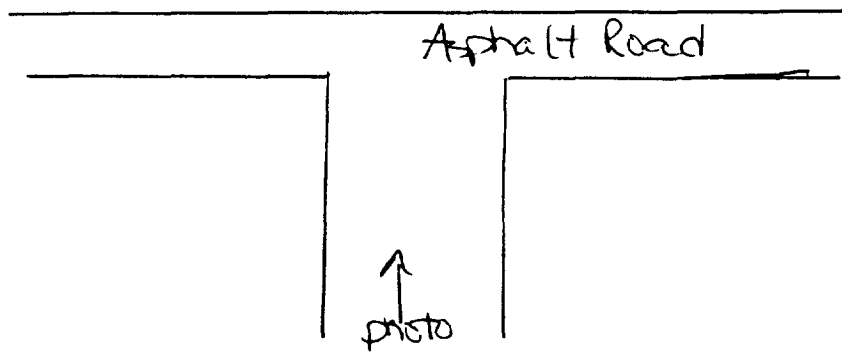
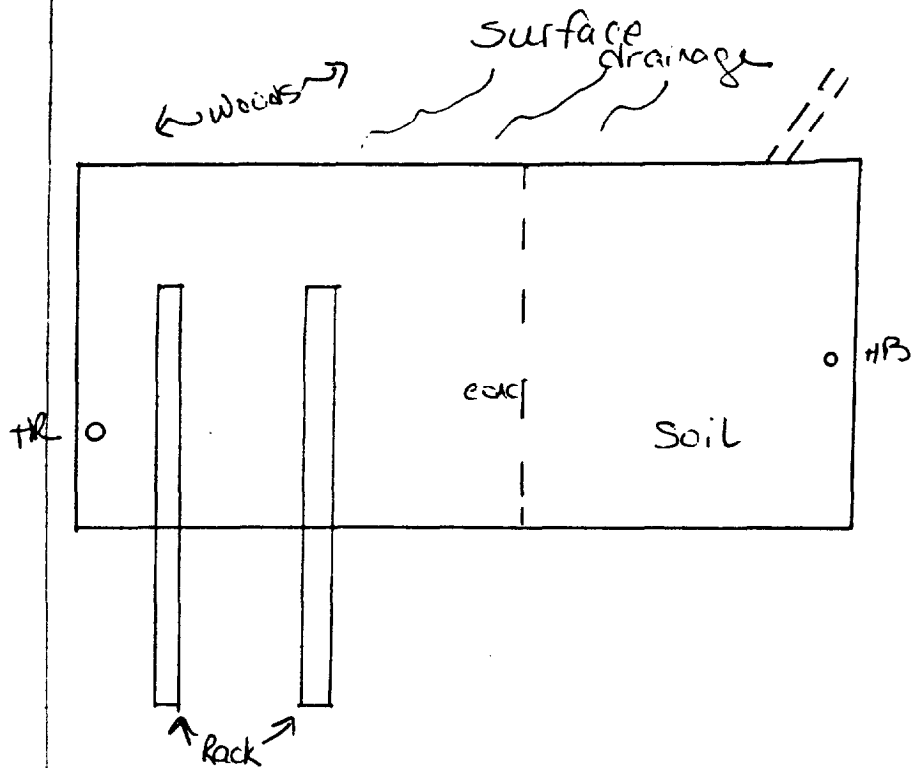

B 68 1916-01W  
Bldg. ~~1916~~ 1916  
Golf Maintenance

12-07-93  
Roll 7  
Photo 20

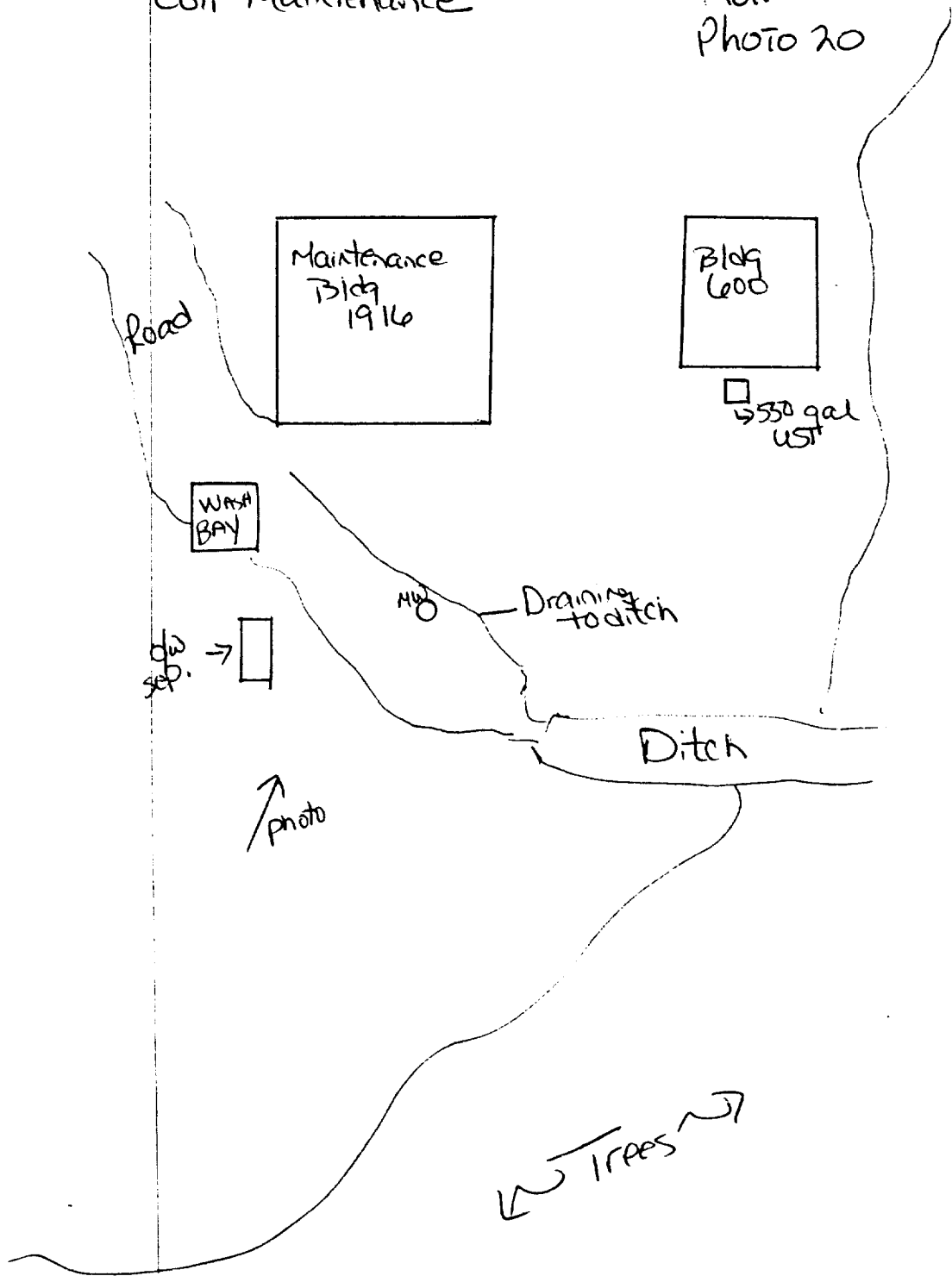

600-UST  
Bldg 600  
Golf Course Maintenance

B-69  
12-07-93  
No photo

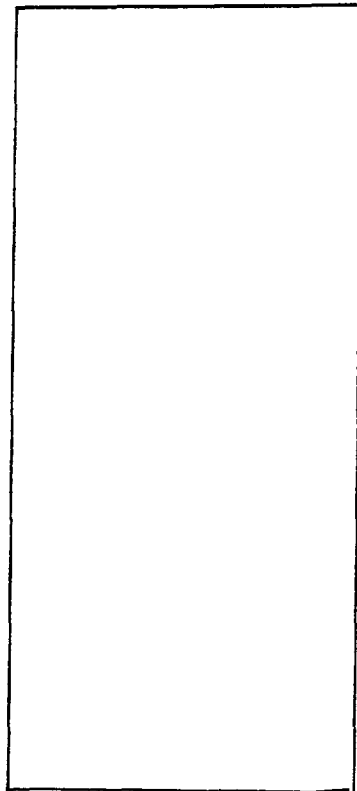
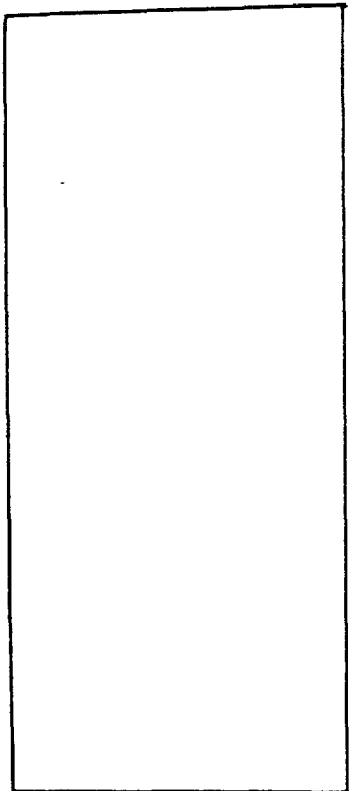
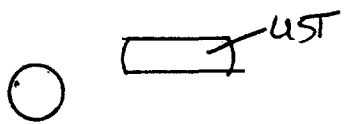

B 70

1775-HWA  
Bldg 1775  
Haz. Waste

12-07-93  
Roll 7/Photo 21 -  
Rum/UB

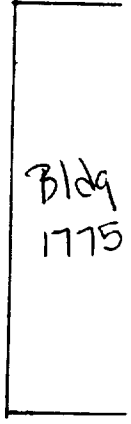
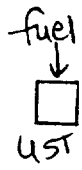
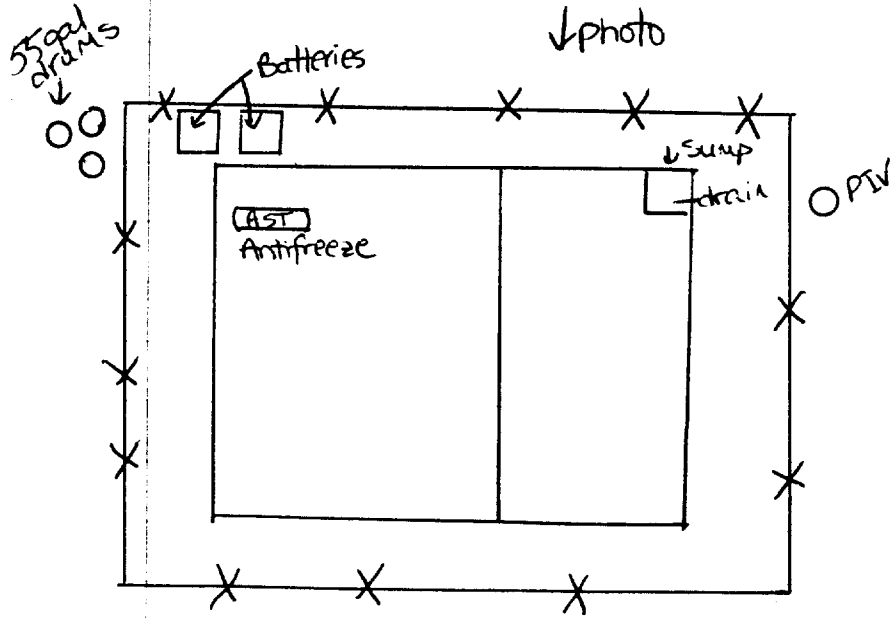

1775-O/W-UST  
Bldg 1775  
Oil / Water Separator  
Wash Rack

12-07-93<sup>B-71</sup>  
Roll 7 Photo 22  
Rwm/LB

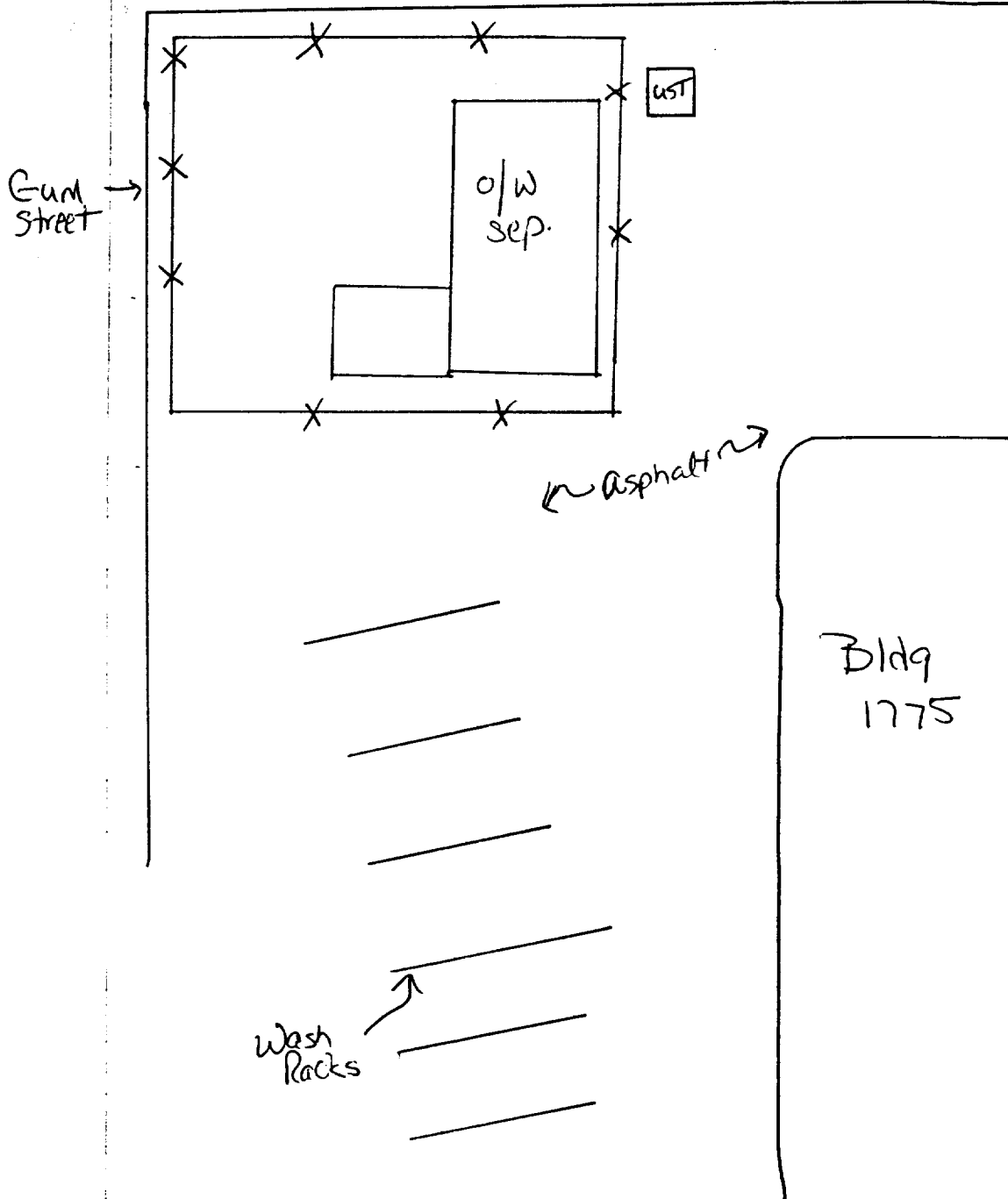

B 72

1175-UST  
Bldg.-1775  
Waste Oil Tank

12-07-93  
Roll 7 Photos 25  
Bm/LS

UST

UST

UST

Bldg 1775

→ photo

— Gun Street

1445-O/W

1207-93 B-73

Bldg - 1445

Roll 7 Photo 26

10th Marines Communications

RWM/LB

Lewis Street

Bldg - 1445

↓ photo

← asphalt →

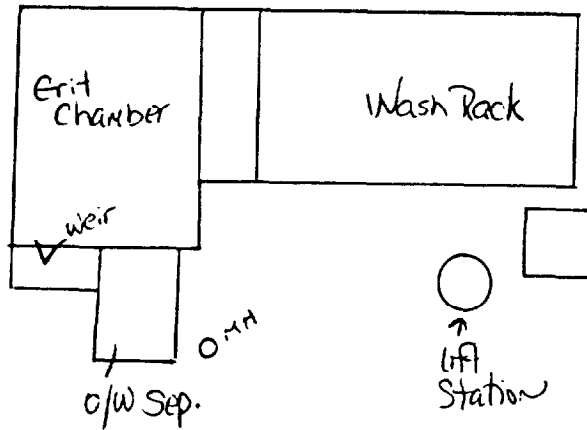

B 24

1343-0/w

1343

10th Marine

1323- HQ BN - Motor-T

12-07-93

Roll 7 Photo 27

Rwm/LB

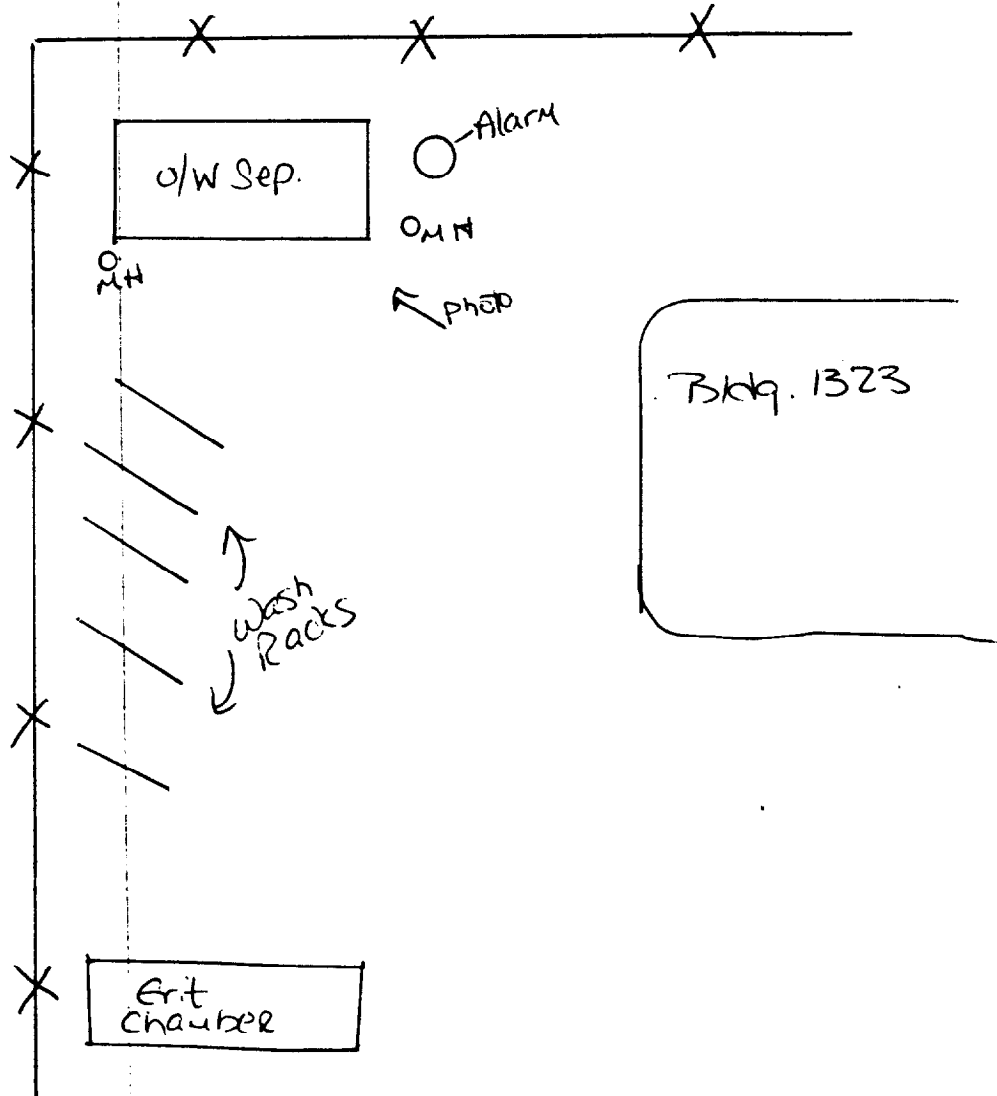



1327/1343-HWA  
1343/1327  
10th Marine  
HQBN Motor T  
<90 day

12-07-93 B-75  
Roll 7 photo 28  
Rwm/LB

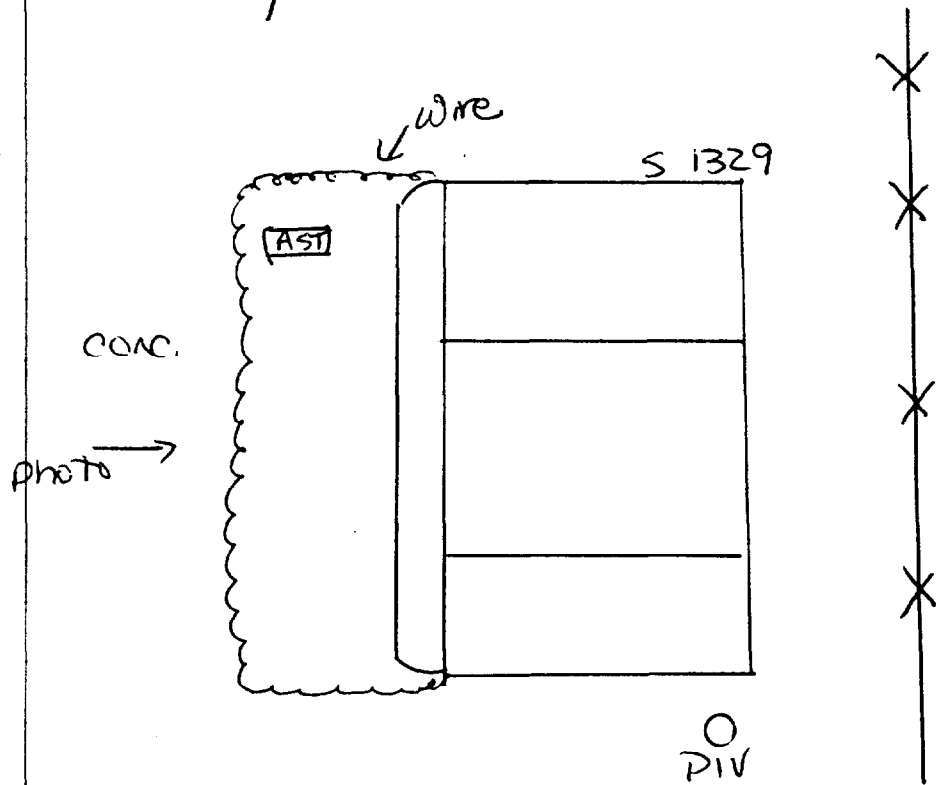

B 74

1323-UST

1323

12-07-93  
Roll 7- Photo 29  
LB

Street →

→ photo

↳ concrete ↷

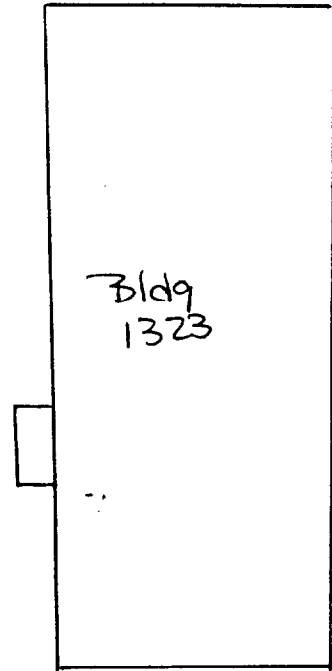

1106/1107-OW 1106/1107-AST 1106/1107-UST<sup>B-77</sup>  
Auto Hobby Shop  
1107/1106

Roll 7 photos 30, 31, 32  
Room/UB  
12-08-93

Michael Street

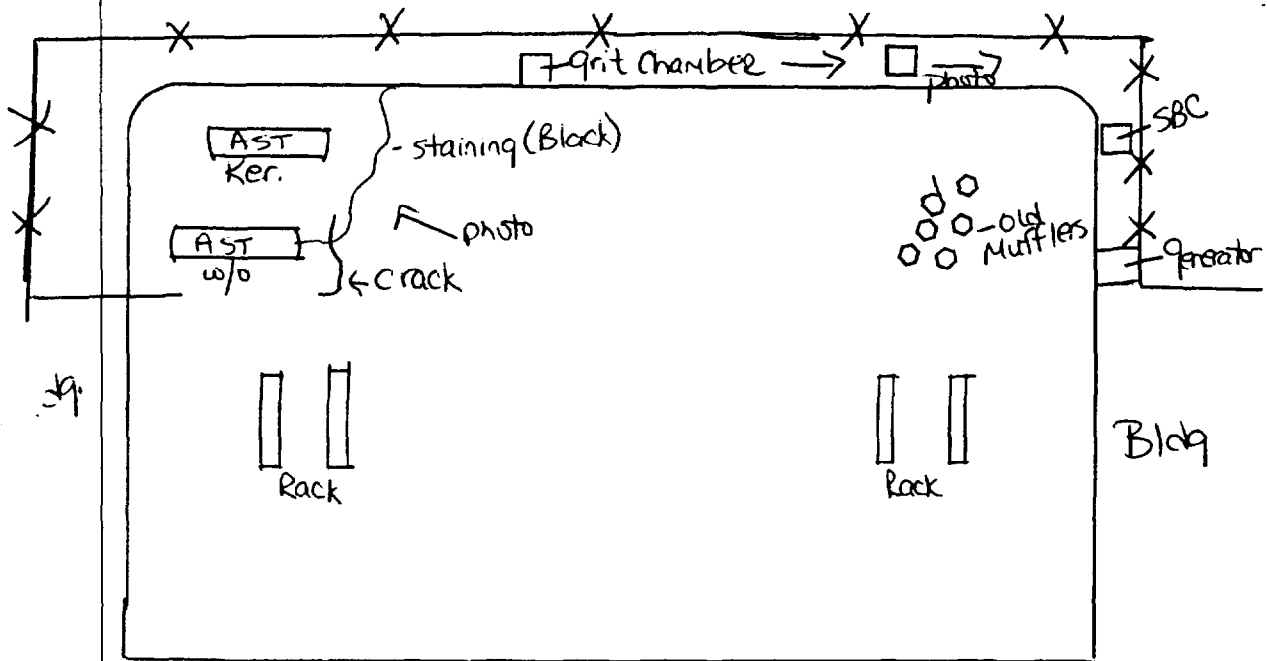

B-78

1205/1206-O/W  
Bldg. 1205/1206

12-08-93  
Roll 7 Photo 33  
Rwm/LB

Cedar Street

Michael Street →

Bldg 1206

Concrete Wash Bay

WASH BACK

grit chamber →

↑ O/W Sep

Photo ↗

Bldg 1205

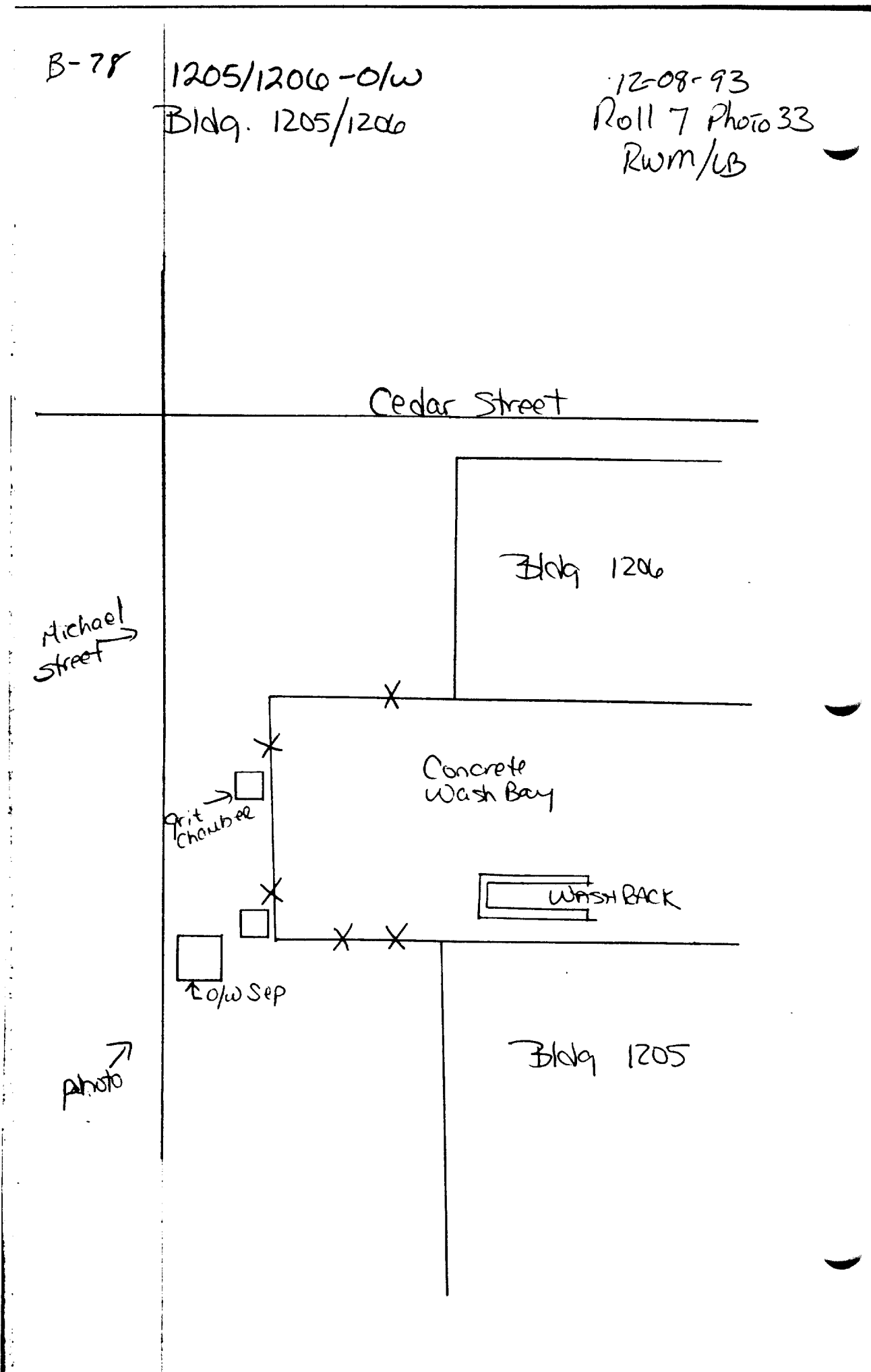

1301/1309-OW

1301/1309-AST 12-08-93 <sup>B-79</sup>

Bldg #1301/1309

Roll 7 Photo 34

Rwm/LB

Dog wood Street

→  
Michael  
Street

OW

Bldg -1301

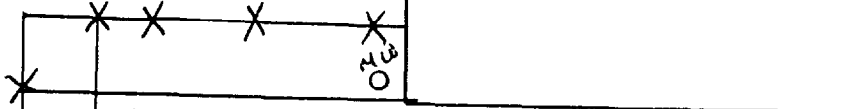

Wash Bay

← CONC. →

grit chamber →

AST

oil  
sep.

Bldg -1309

↗  
Photo

B 80

Bldg 1405 / 1406 - o/w  
Oil/H<sub>2</sub>O Separator

ROLLS PHOTO ~~2~~ <sup>2</sup> ~~0~~ <sup>lin</sup>

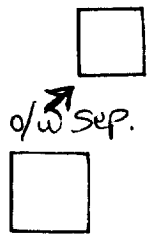

Bldg  
1406

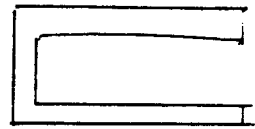

↑ CONC.  
wash  
rack

↑ 15000



↑ 15000

Bldg  
1405

B-81

Bldg 1612

Row 3 Photo 1  
RWMB

West →  
Road

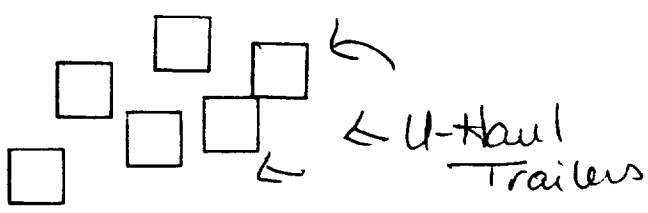
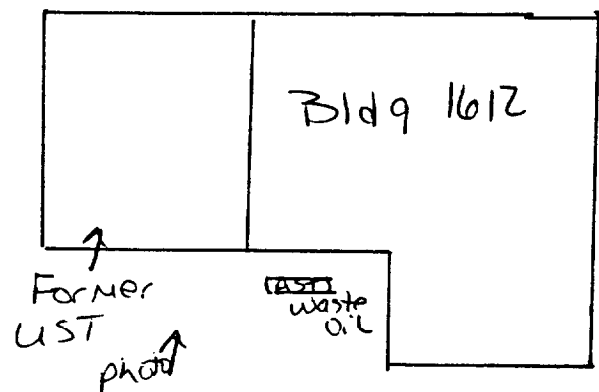

Gun street

B02

Bldg-1505/1506

Roll 8 Photo 0  
LWM/LB

Bldg  
1506

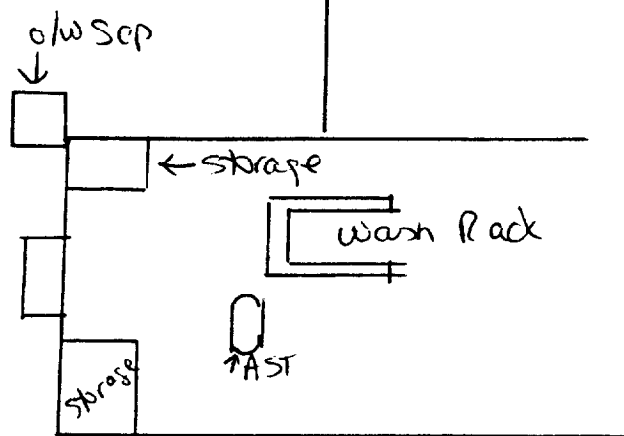

Michael  
Sheet

Photo →

Bldg-1505



AS431  
MC A5  
AS431

12-8-93 B-83  
Roll 8 Photo 4  
LB

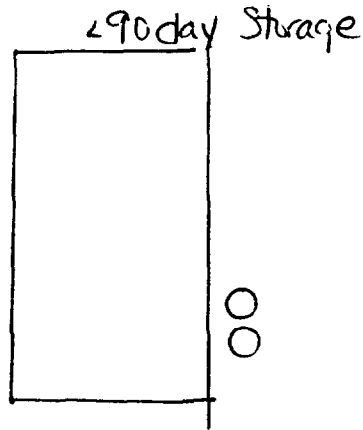

gravel

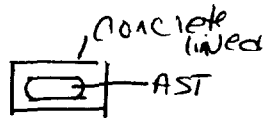

→  
photo

AS  
504

↙ Mat Aircraft Parking ↘

B 84

AS 504-O/W  
MCAS  
H MT 204  
Wash Rack/Oil/H2O Sep

12-8-93  
Roll 8 Photo 5  
LB

AS 504

Aircraft Parking

concrete

Wash Area

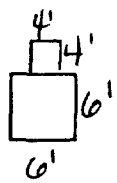
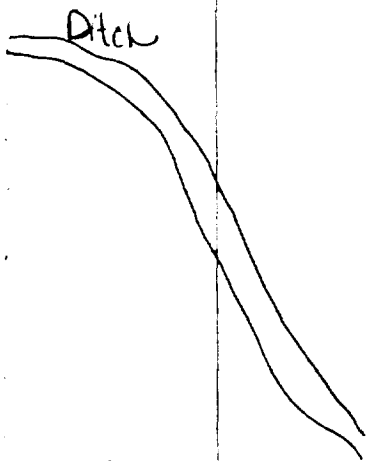

oil/H2O Sep

ASE04-AST  
MCAS  
AS 566  
w/o AST

12-8-93 B-85  
Roll 8 Photo 6  
LB

Hel  
Parking

Hanger  
AS-504

AS-566

← Asphalt →

↓ Photo

← grass →



waste Oil

B86

AS-515-HWAE ASSIS-AST-E

12-8-93

MC A5

Roll 8 Photo?

AS-515 east end

LB

< 90 day

Hel  
Parking

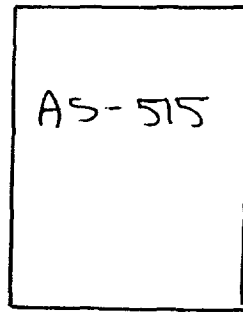

staining (oil)

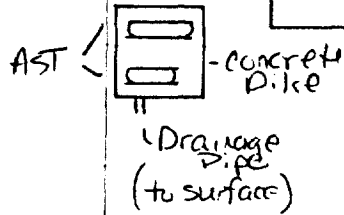
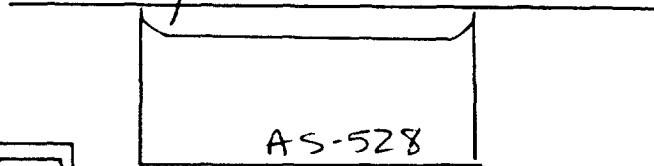

← glass →

AS574-AST AS574+HWA  
MCAS  
<90 day

12-8-93 B 97  
Roll 8 Photos  
LB

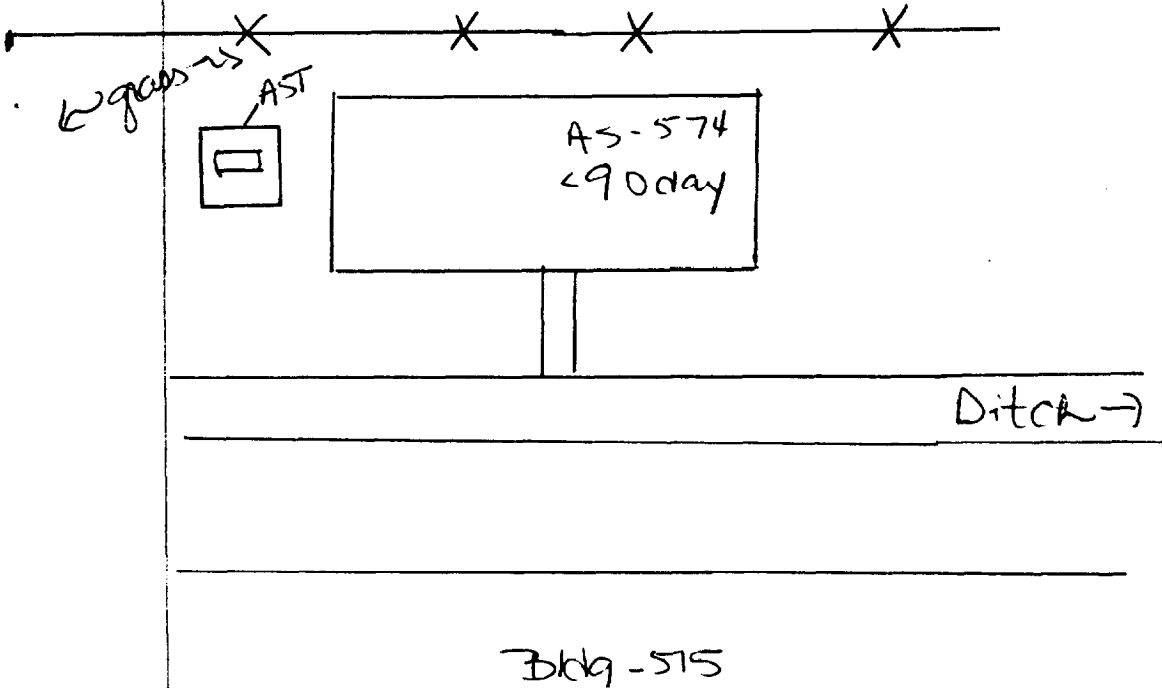

B 88

AS525-HWA AS525-AST

12-8-93

MCAS

Roll 8 Photo 9

AS-525

LB

Hanger  
261

90day

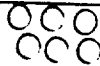

AST

Hel.  
Parking

← photo

← grass →

AS3905-HWA AS3905-AST  
MCAS  
AS 3905

12-8-93 B & P  
Roll 8 Photos  
10 & 11  
LB

AS 3905

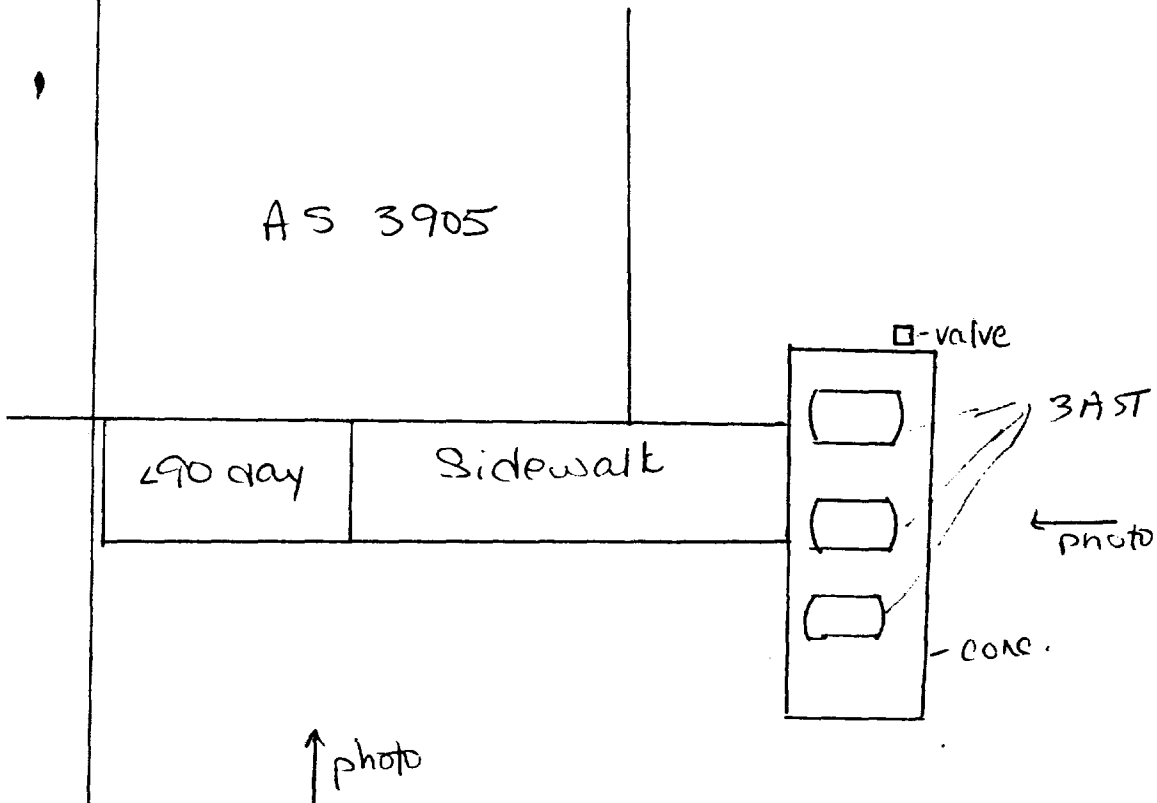

B 90

AS3905-0/w  
MCAS  
AS-3905

12-8-93  
Roll 3 Photo 12  
LB

concrete  
wash  
Area

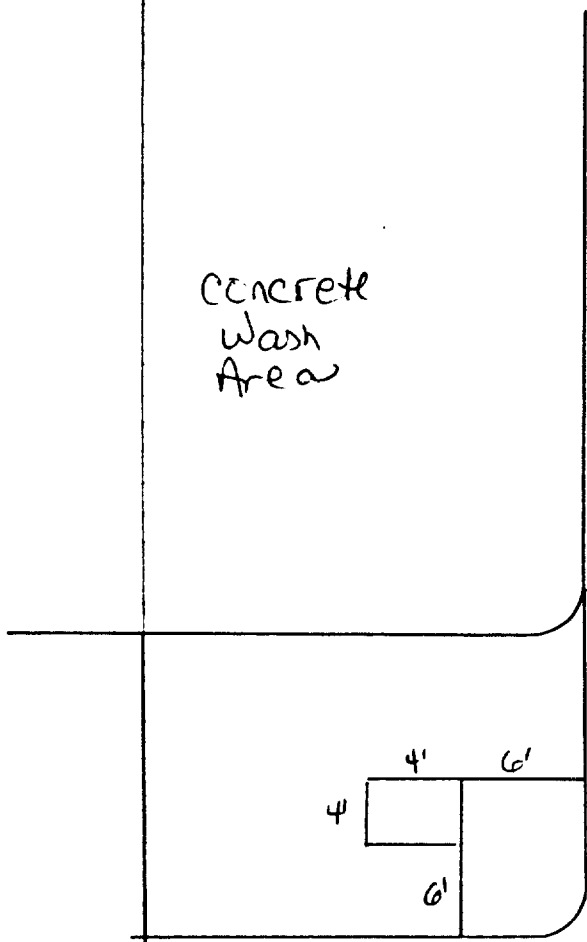

sidewalk

490

3905



AS4112-HWP AS4112-AST 12-8-93 B 91  
MCAS Roll 8 Photo 13  
LB

Hel.  
Parking

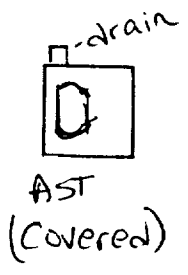
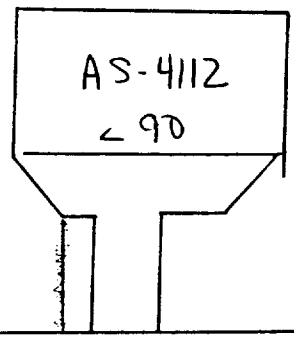

Hanger 4100

B 92

AS4134HWA  
MCAS  
AS 4134  
290

12-8-93  
Roll 3 Photo 14  
LB

4108

Hel.  
Parking

Trailer

← concrete →

AS-4134

photo  
←

AS-4133

4106

AS4114AST, AS4114-HWA  
MCAS

12-8-93. B 93  
Roll 8 Photo 15  
LB

4108

old 90 storage  
Bldg 4114 ← not active

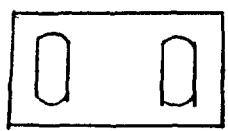

AST's  
↑ photo

B-94

AS 4108-AST

MCAS

AS 4108

12-08-93

Roll 8 Photo 10

LB

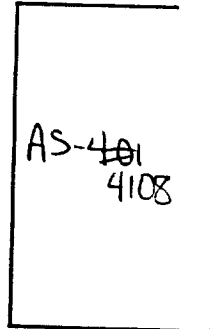

COAC  
CURB

← photo

Hel.  
Parking

← asphalt →

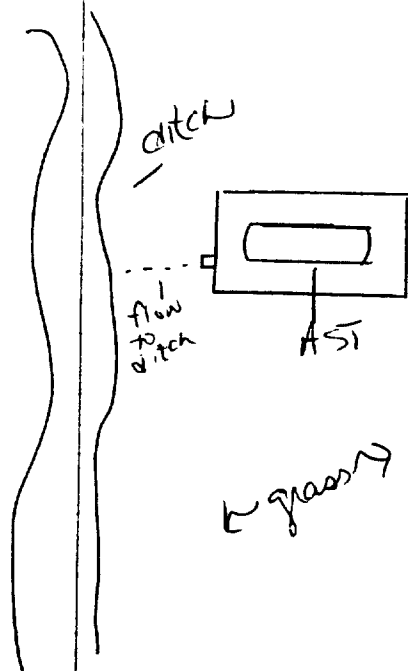

AS4115-HWA AS4115-AST

B- 95

MCA5

12-08-93

AS-4115

Roll 8 Photos 17 & 18

LB

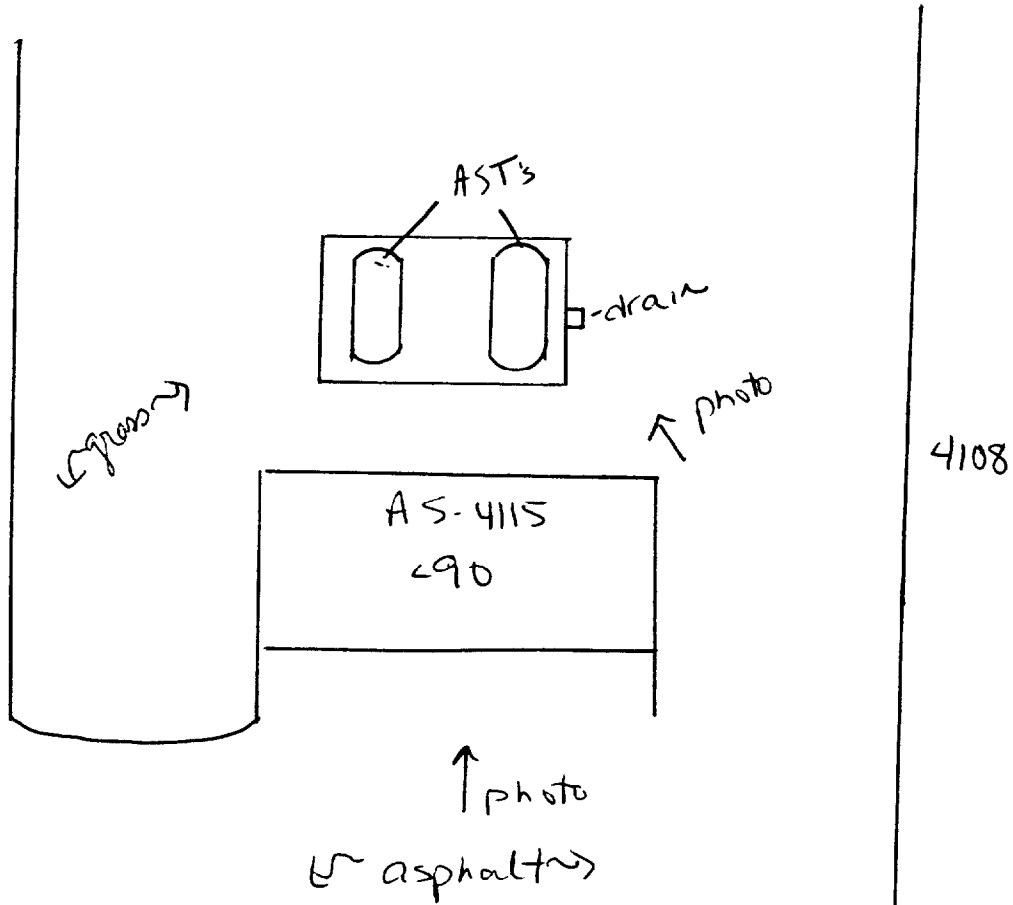

B-96

AS4135-UST, AS4135-HWA, AS4135-o/w

AS4135

12-08-93

Roll 3 Photo 19

LB

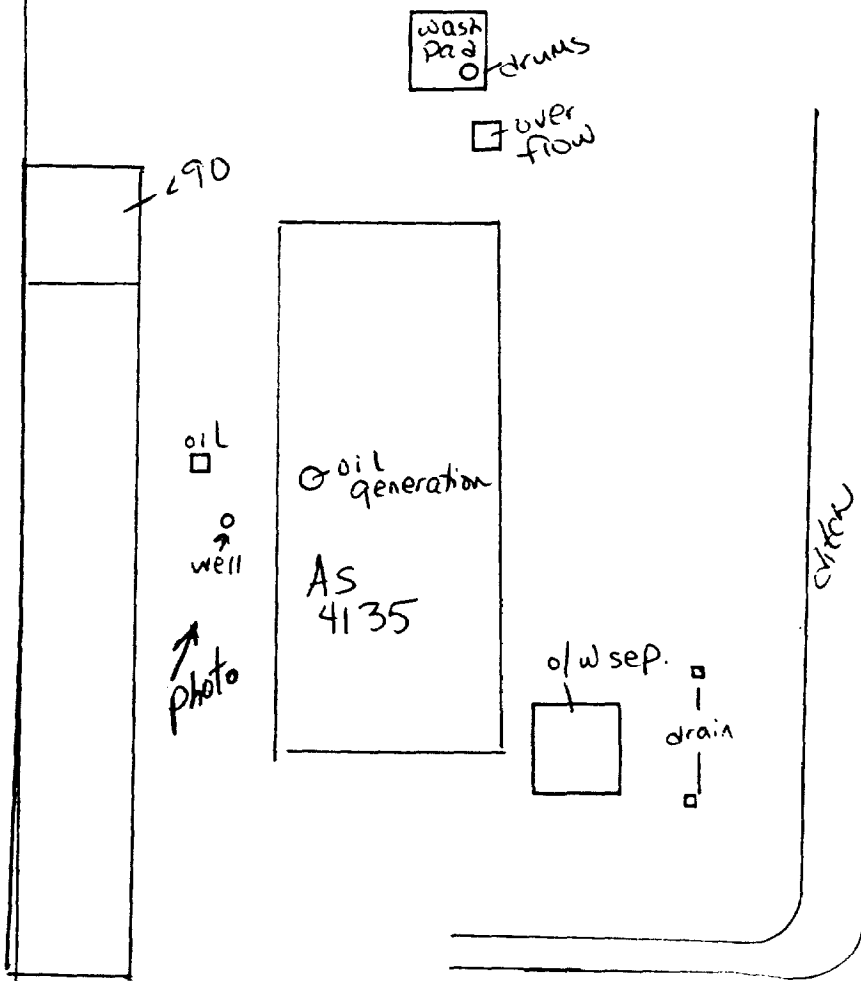

AS226-STILL

B-97

MCAS

12-08-93

Solvent Still

No Photo

AS-226

LB

AS-226

D-still

B-98

AS515-01W  
MCAS

12-08-93  
Roll 8 Photos 20:2  
LB

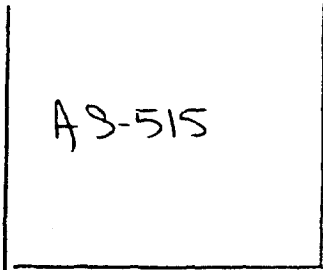

Hel. Parking

↓ photo

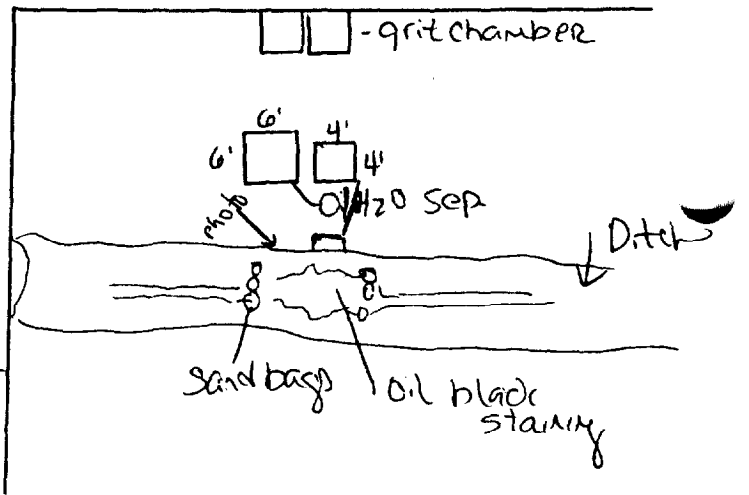

AS-524



AS 576-0/w, AS 576-AST  
MCAS  
Bldg. 576

3-99

12-08-93  
Roll 8 - Photo 22  
LB

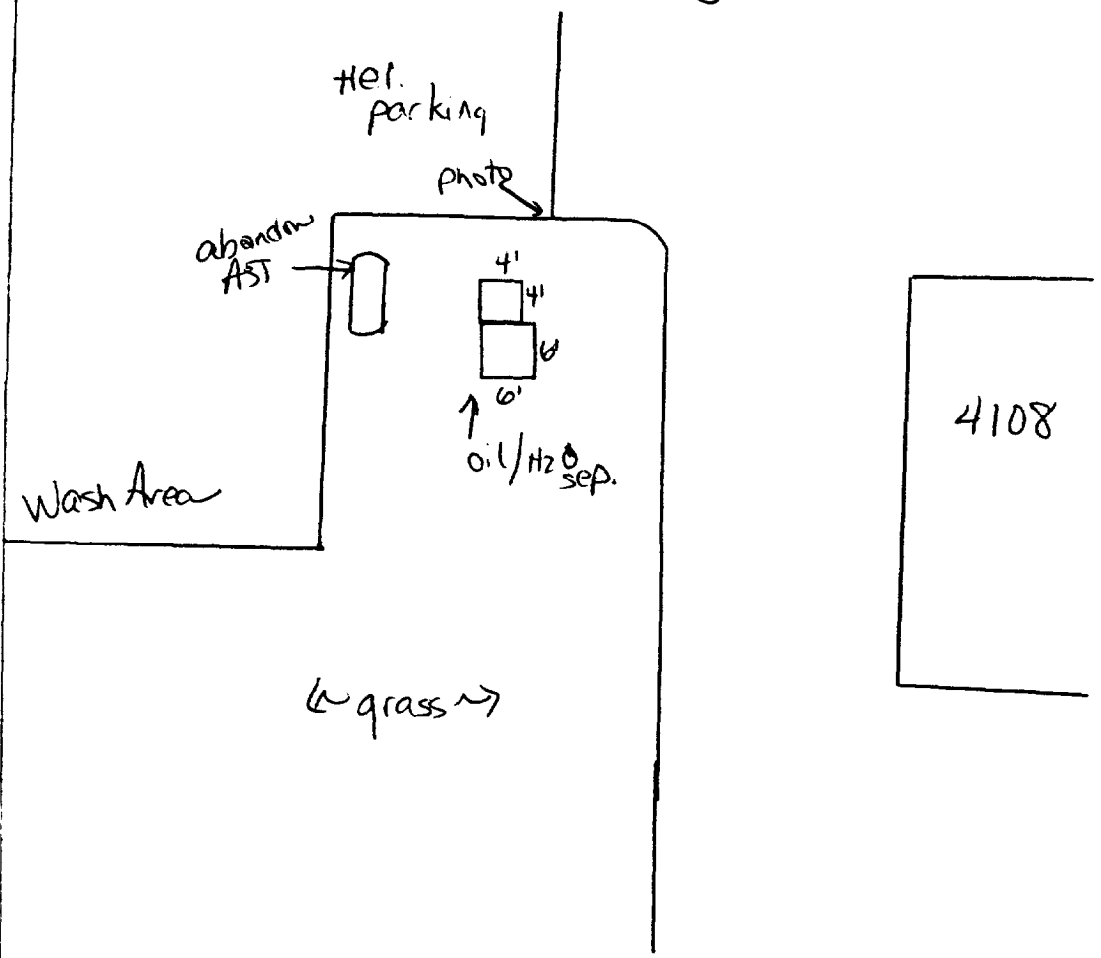

B-100

AS-PIT-UST

MCAS

Burn pit

12-09-93

Roll 8 Photo 23

LB

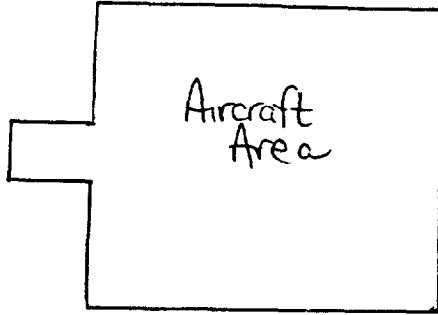

photo

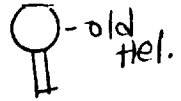

grass

Burn pit

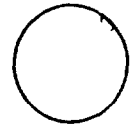

holding for JP-5 fuel



AS592-0/w

B-101

NOAS

12-09-93

Aircraft Engine test cell

Roller-Photo24

AS-4108

4106

Hel. Parking

Ditch

plot

OPIV  
(open)

Engine  
test  
Facility

oil/H<sub>2</sub>O  
sep

staining  
on  
rails

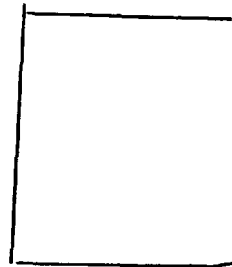

B-102

AS499-0W

MCA S

AS-499

12/69/93  
Roll 8 - Photo 25  
LB

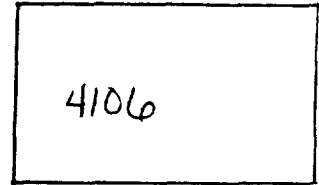
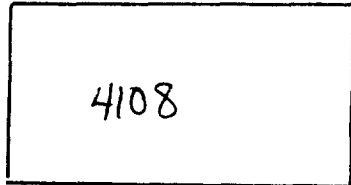

Hel. Parking



Ditch

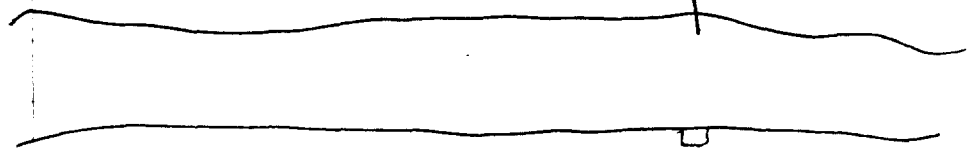
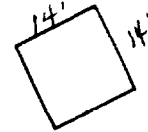
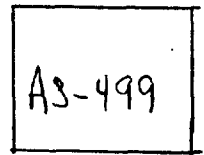

photo →

grass →



oil/A20 Sep.



AS4159-0/w, AS4159-AST  
MCAS  
MW55-272  
2<sup>nd</sup> Marine Aircraft Wing

B-103

12-09-93  
Rolls Photos 26/27  
LB

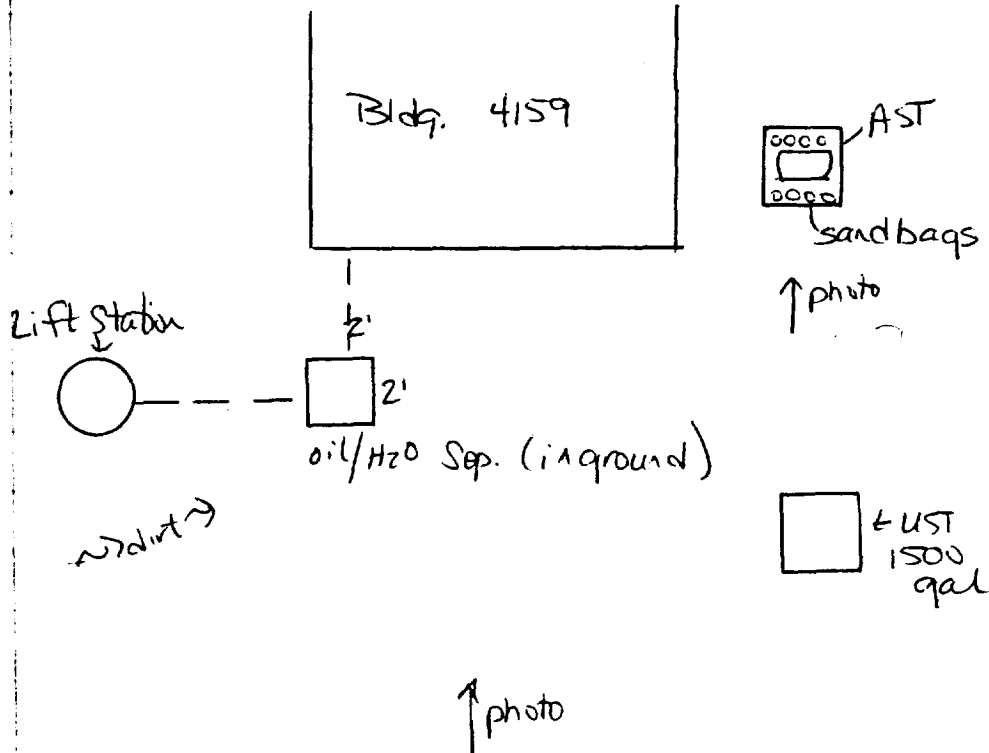

B-104

AS4158-0/w

MCAS

MCSS-272

2nd Marine Aircraft Wing

12-09-93

Roll 8 - Photo 28

LB

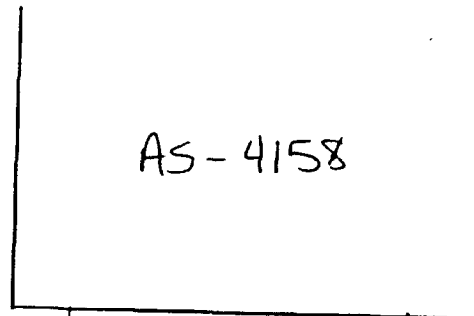

AS-4158

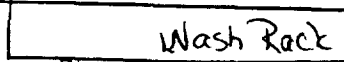

Wash Rack



oil/H<sub>2</sub>O Sep.  
(in ground)

↑ photo

street

AS4158-HWA

B-105

NCA's

12-09-93  
Roll-8-Photo 29  
LB

MWSS-272

Group 27

↓ chain link fence

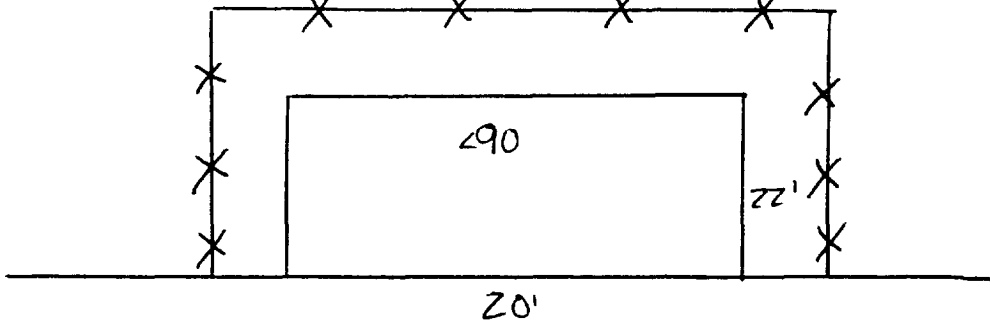

↑ photo

← asphalt →

Bldg. 4158

B-106

AS143-0/w  
MCAS  
Fuel Division  
Supply Dept.

12-09-93  
Roll & Photo 30  
LB

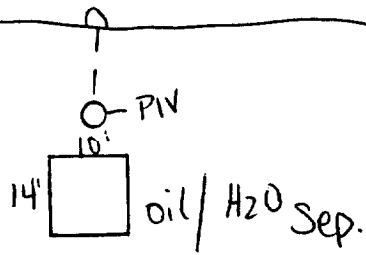
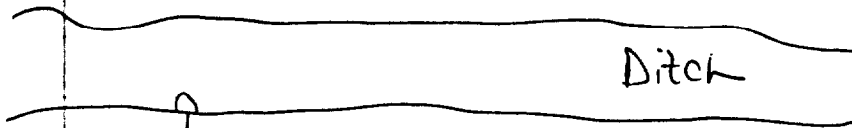

grass →

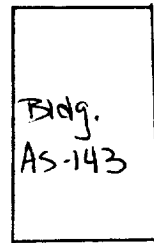
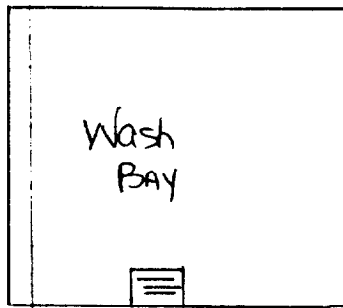

← Campbell street

↑  
white street



AS119-Rack  
Base Motor Transport

B-107  
1209-93  
Rolls Photo 31  
LB

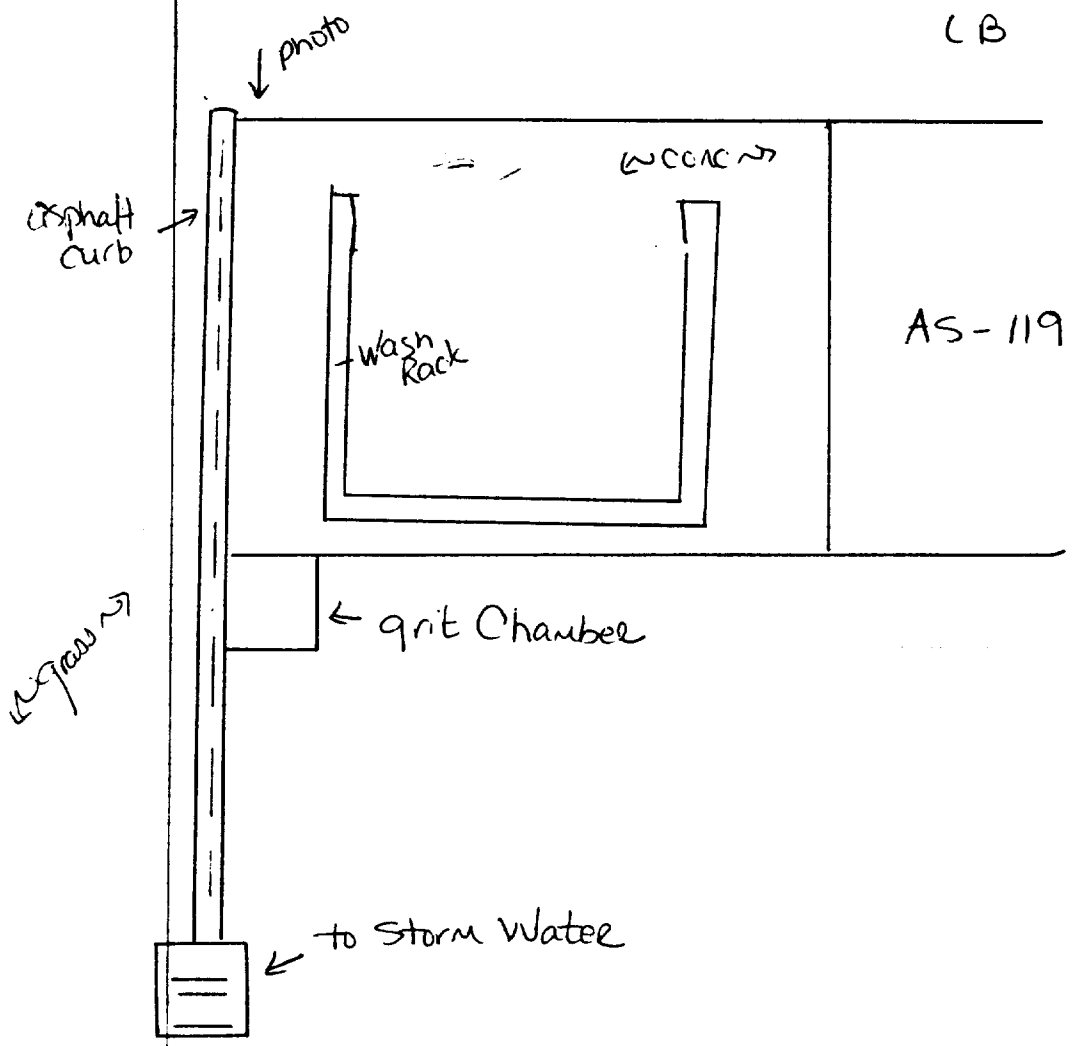

B-108

AS123-0/W  
MCAS  
Car wash

12-09-93  
No Photo  
LB/Rwn/Bm

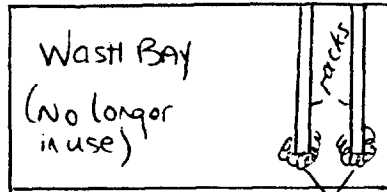
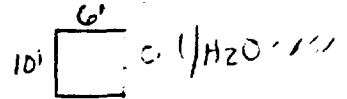
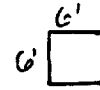
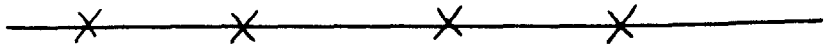

Barbwire

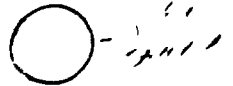

↳ asphalt ↵

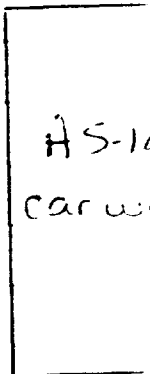

AS-11'  
car wash

AS118-~~ATW~~<sup>Q</sup>  
MCAS  
Motor T  
AS-118

B-109

12-09-93  
Roll 6 - Photo 32  
LB

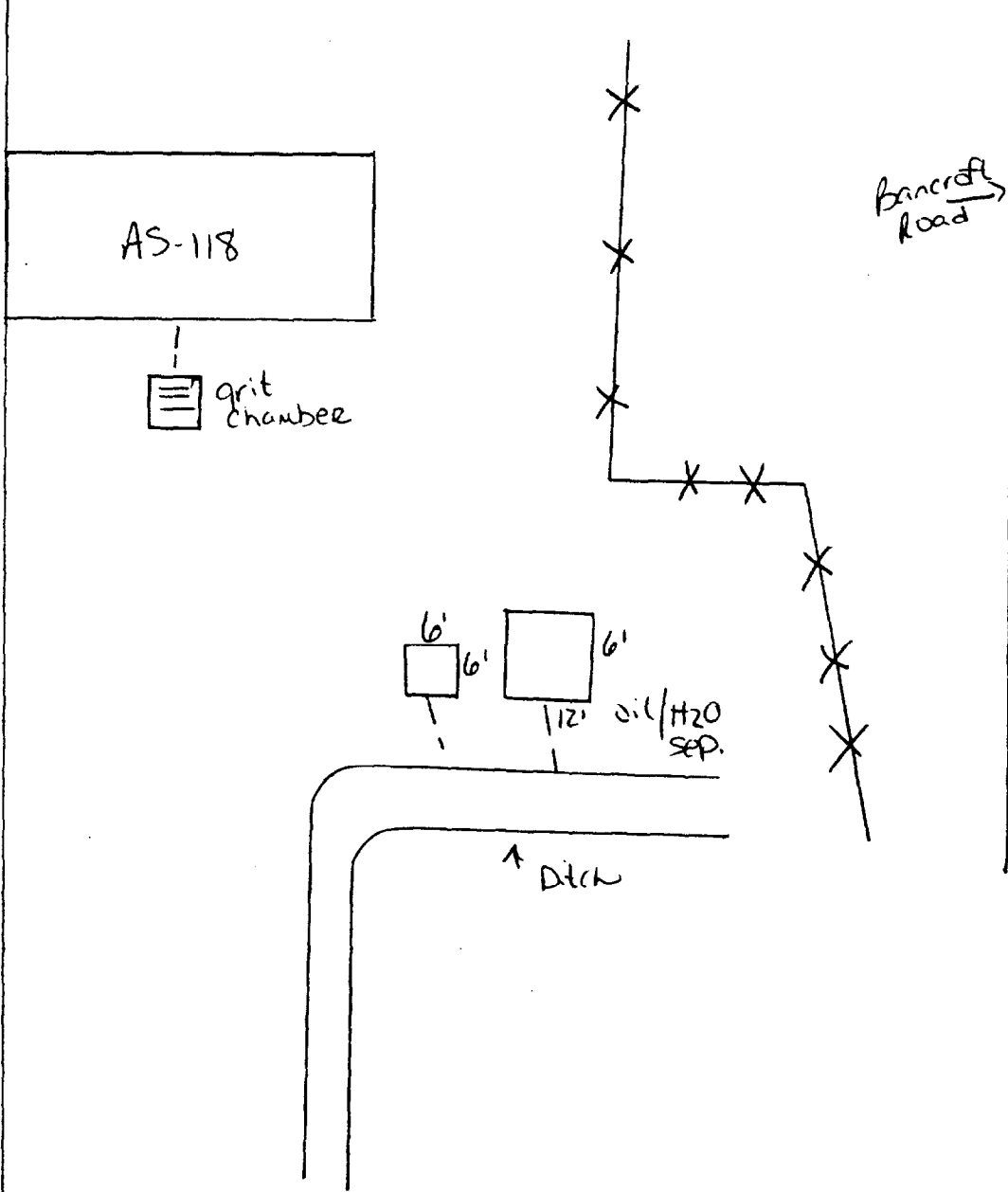

Note: See Page B-38 and Roll 6-Photo  
20 - "Duplicate"

B-110

AS118-AST  
MCAS AS118  
Motor T

12-09-93  
Roll 8 Photo 33  
LB

Bancroft Road

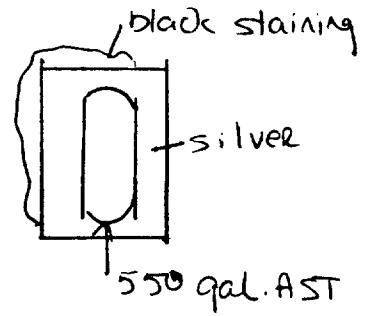
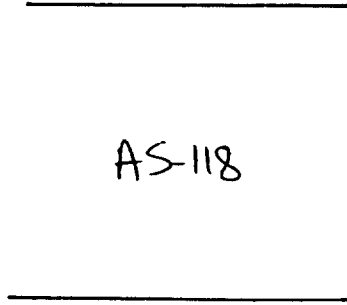
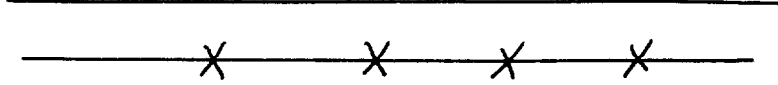

AS114-AST  
MCAS  
Auto Hobby Shop

B-111

12-09-93  
Roll B-Photos 34/35  
LB -

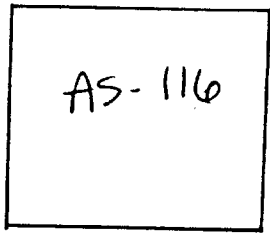

↙ asphalt ↘

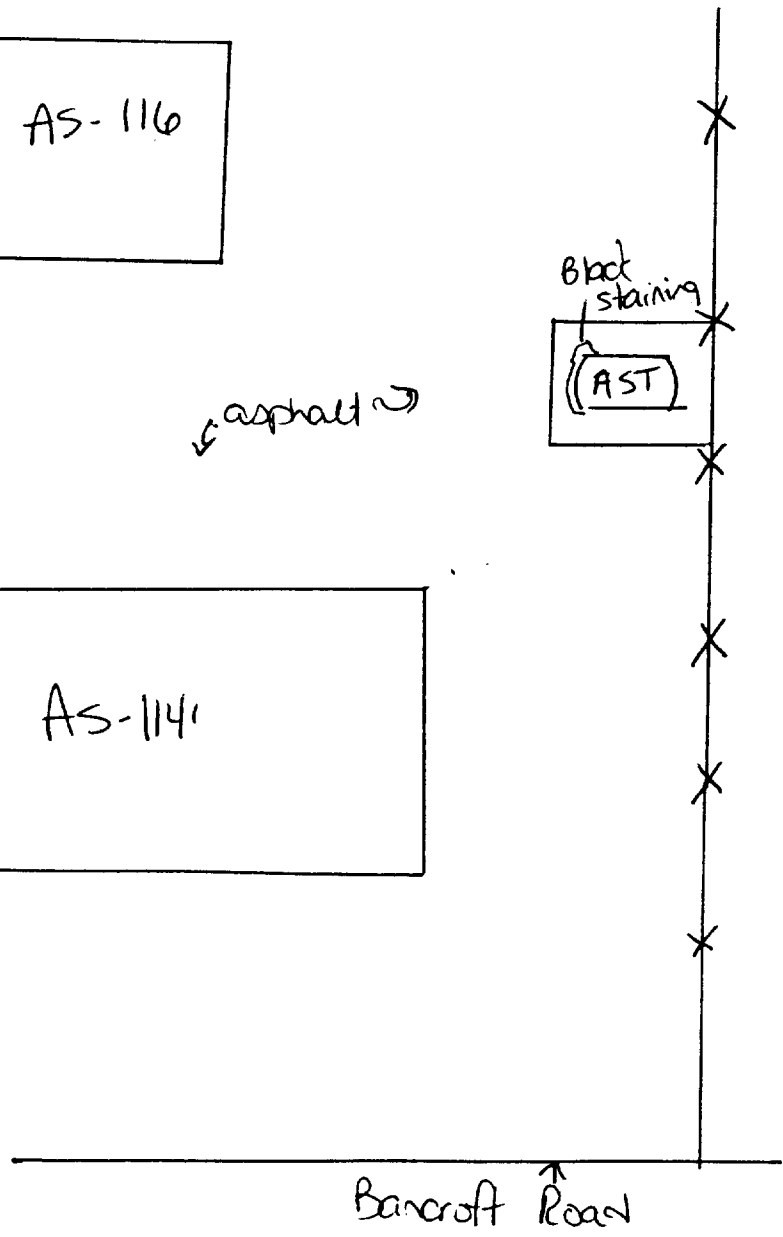
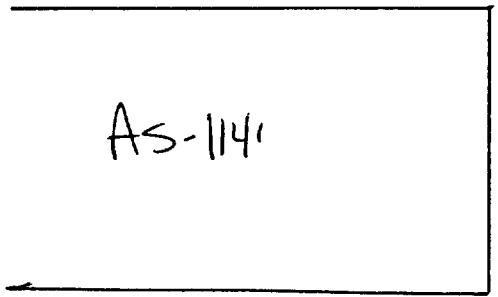

B-112

AS3020 AST  
Helicopter  
Flight Simulator

12-09-93  
Roll 9 Photo 0  
LB

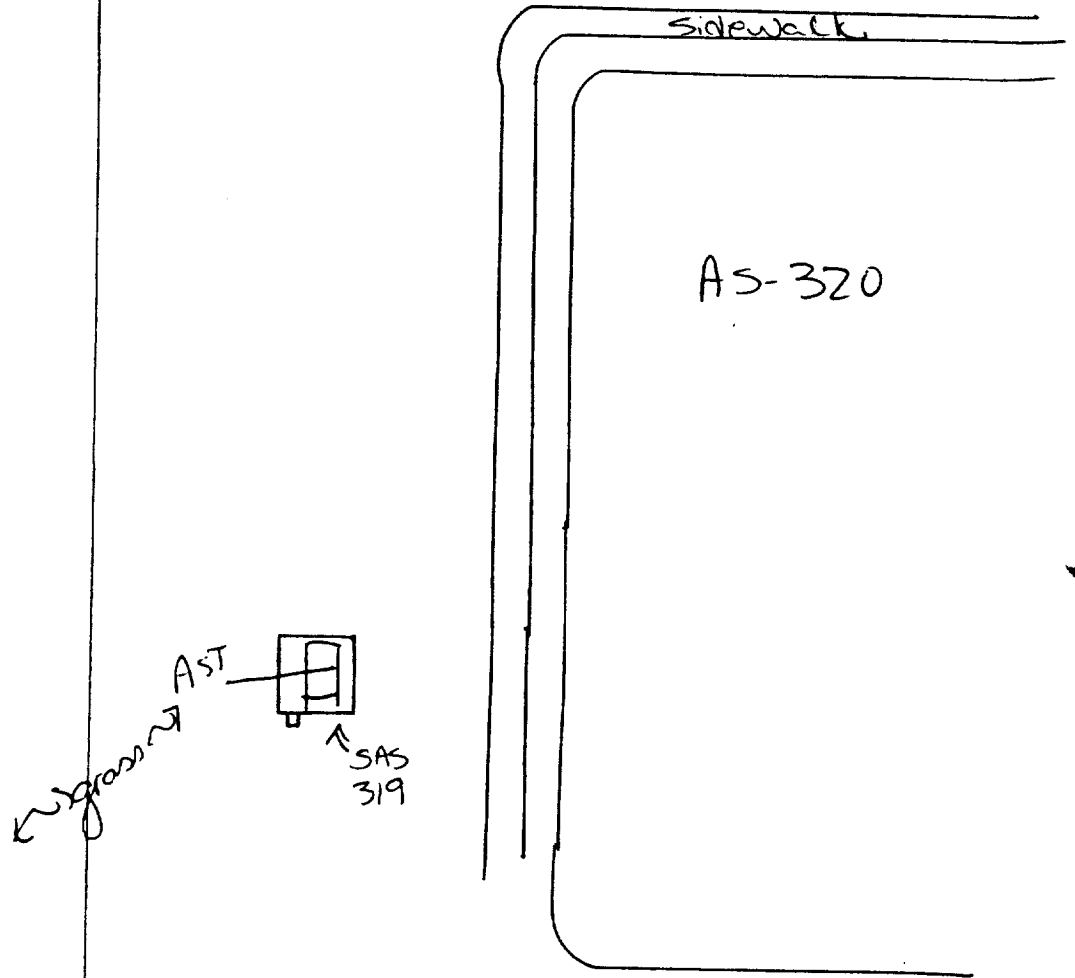

ASBESTOSWA, AS605 O/W AS605UST . B-113

ACAS  
AS-605

12-09-93  
Roll 9 Photo 1  
Lb

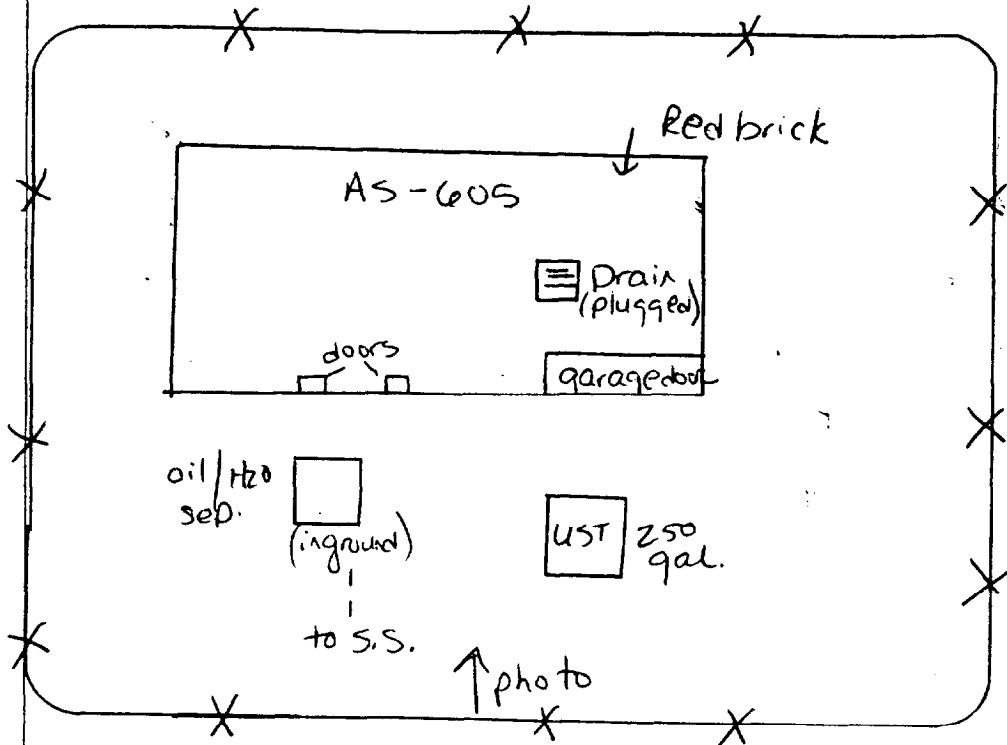

B-114

EGT-UST, CG10/w

MACS

Air Traffic Control

12-09-93

Roll 9 Photos 2, 3

LB

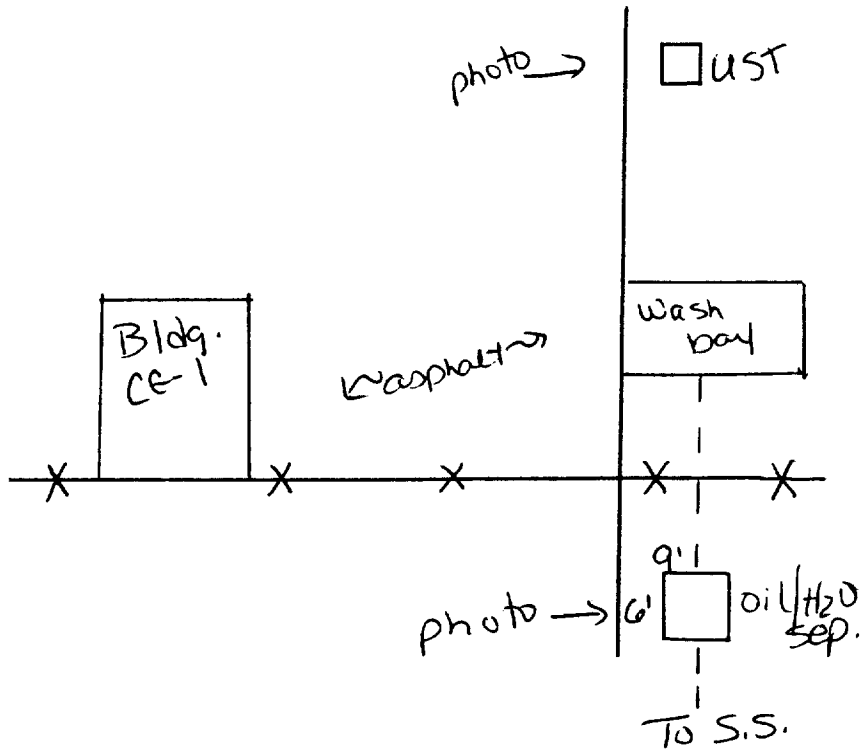



AS4158-AST  
MCAS  
MWSS-272

B-115

12-09-93  
Roll 9 Photo 4  
LB

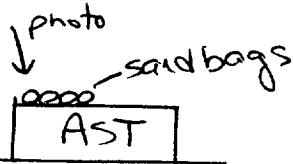

Fueling  
Station

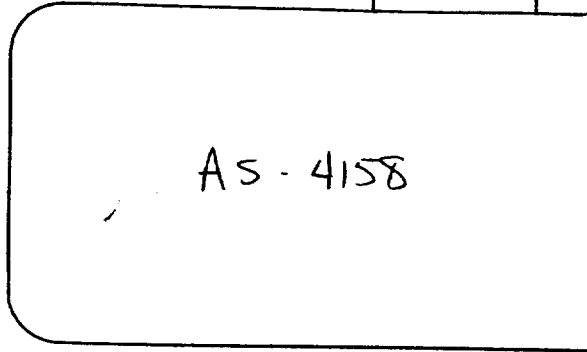

AS-4158

Demarco Street

B-116

Curtis-Ditch

Skimmer No. 5

12-09-93

Roll-9 Photo 6

Zoom / 8m

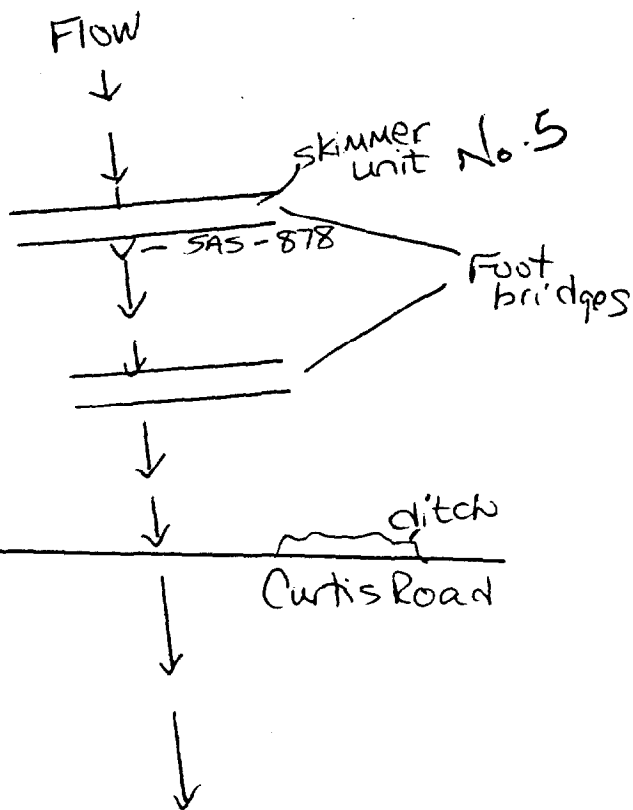

Longstaff-Ditch  
Skimmer # 8/4 Rn

12-09-93 B-117  
Roll 9 Photo 7  
Rwm/Bm

↑ Airfield

Skimmer # 5 1 Rn

well

↓ Flow

pipeline

skimmer  
unit →

concrete

Longstaff Rd

↑ photo

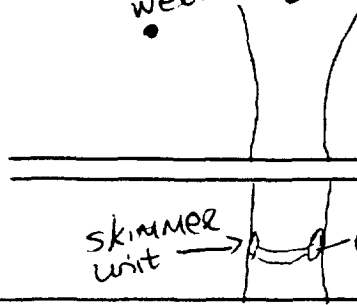

B-116

SAS 3503-AST

SAS 3503-O/W

AS 3504-AST

12-09-93  
Roll 9-Photos 8  
Rwm (Bm)

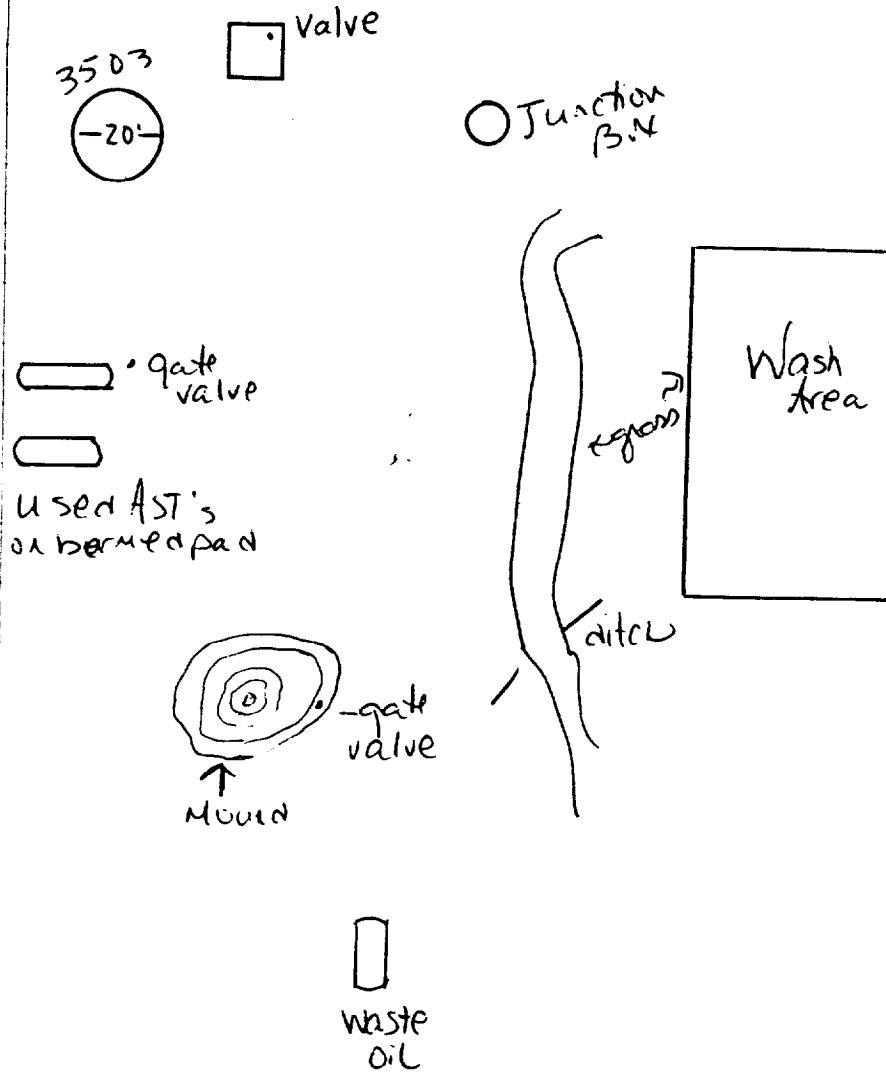

AS-3003  
Skimmer #2

12-09-93 B-119  
Roll 9 Photo 9  
Rwm/Bm

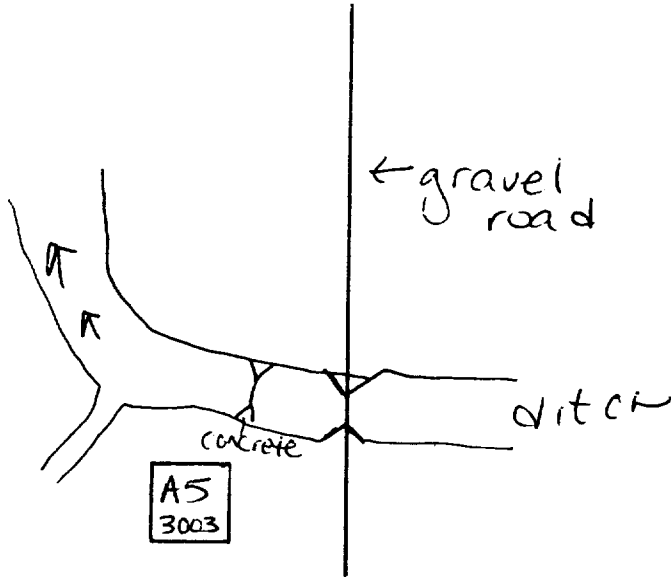

B-120 Primmington  
Skimmer #3

12-09-93  
Roll 9 Photo 10  
Rwm/Bm

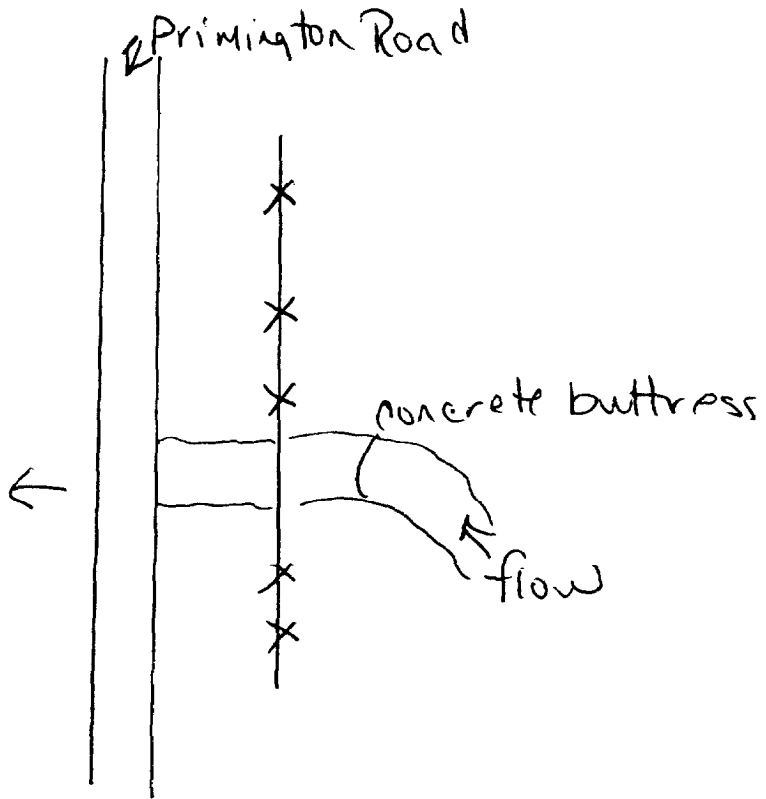

B-121

Jet Engine Test Cell

12-09-93  
Roll 9 Photo 11  
Rwm/Bm

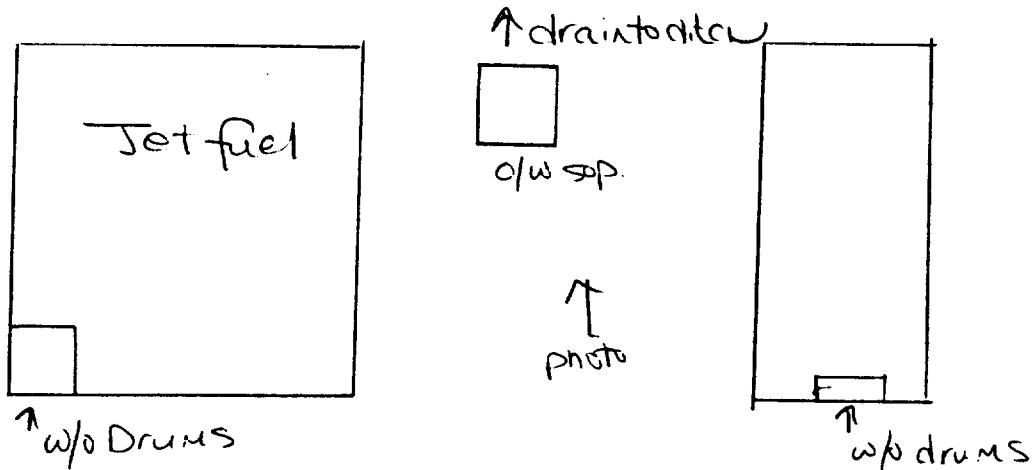
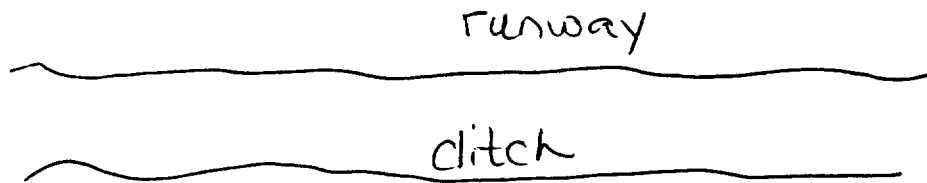

Note: see page 102 -  
Duplicate

B-122

Skimmer #4

12-09-93  
Roll 9-Photo  
Bwm/Bm

station  
ordnance

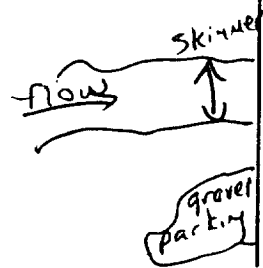

Road

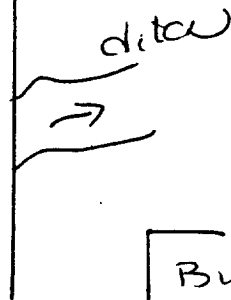



STC874-96, STC868-Rack, STC872-Pile B-123  
STC872 12-09-93  
Roll 9 Photos 13, 14, 15

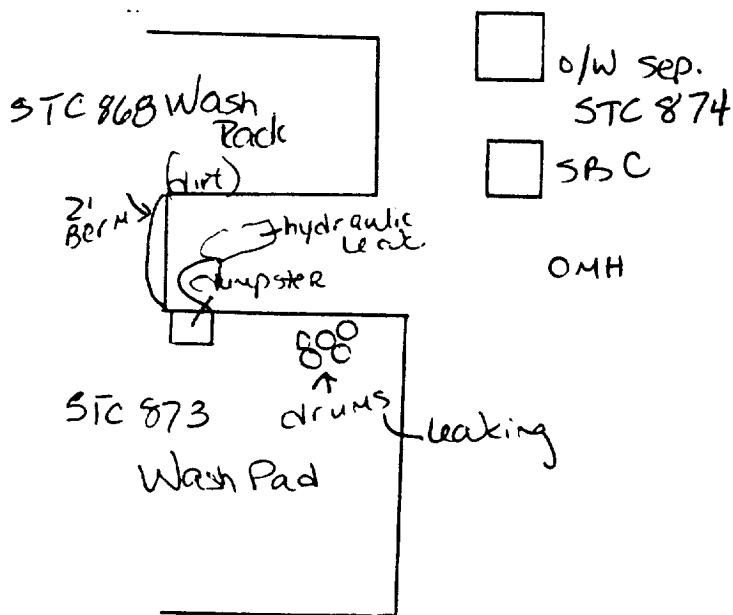
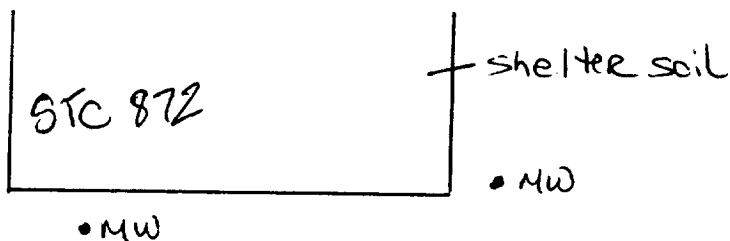

B-124

TC 811-0/w

12-09-93  
Roll 9 Photo  
Rwm/Bm

B

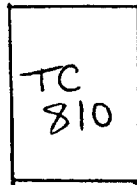

HBO  
HBO



o/w Sep.

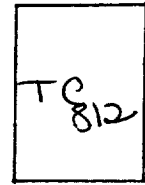
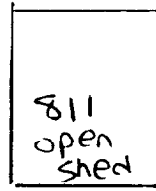

sm624-Rack  
Washpad Bldg

B-125

12-09-93  
Roll 9 photo 17  
Rwm/Bm

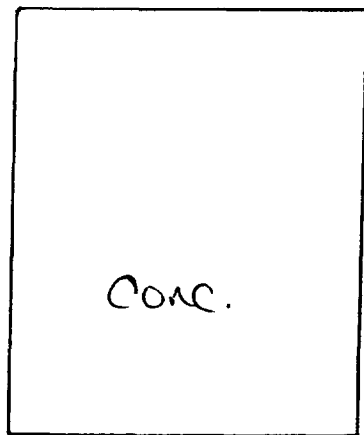
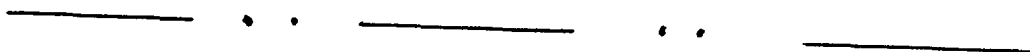

↑  
photo

B-126

M 105-Rack  
M-105

12-09-93  
Roll 9  
Photo 18  
Rwm/Bm

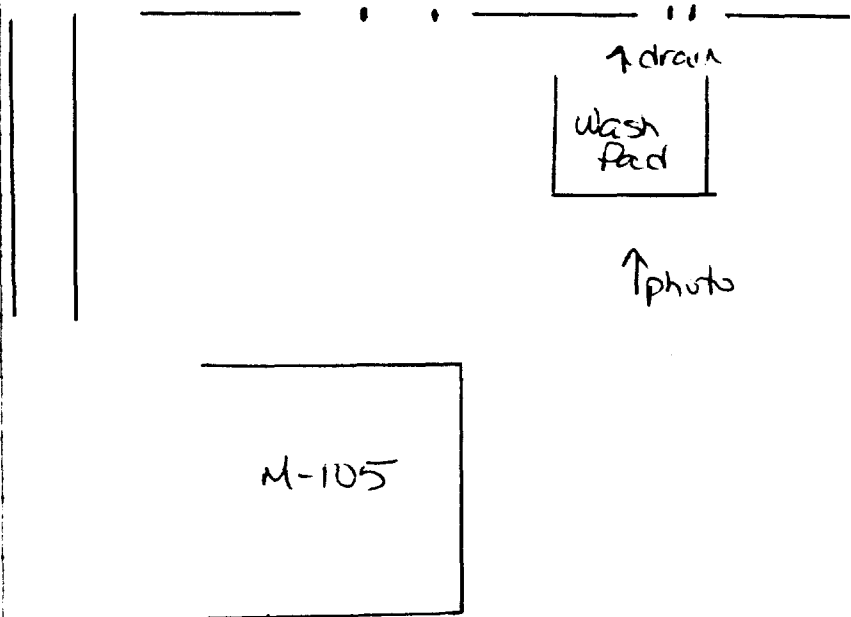

SA-45-o/w  
AA

12-10-93 B-127  
Roll 9  
Photo 22  
Rwm/Bm

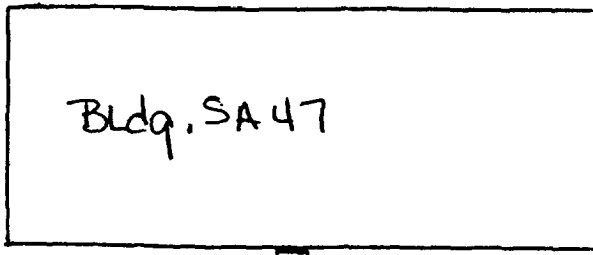

□  
oil/water Sep  
SA-45  
↑ photo

B-128

45-POND  
Bkg. 45  
Pond (Spill Containment)

12-10-93  
Roll 9  
Photos 17, 20  
Rwm/Bm

woods

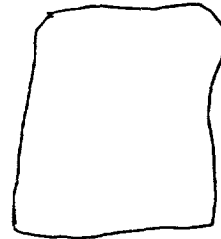

diked  
pond

45-AST  
Bldg. 45

12-10-93 B-129  
Roll 9  
Photo 21  
Rwm/Bm

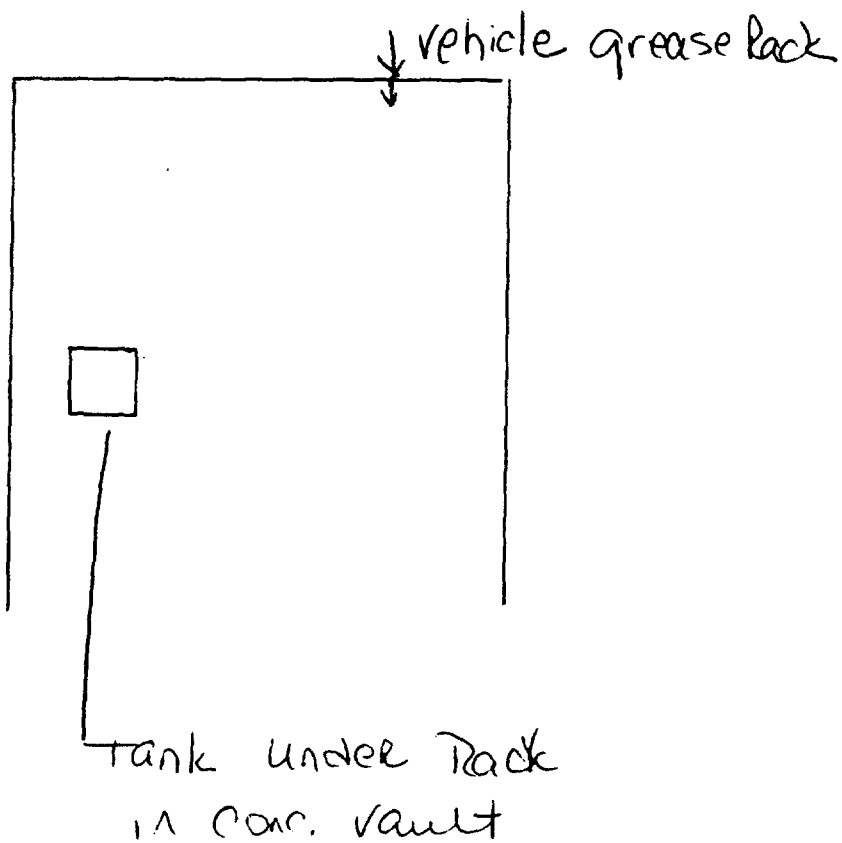

B-130

BB161-4ST

12-10-93  
Roll 9  
Photos 23, 24  
Room / Bm

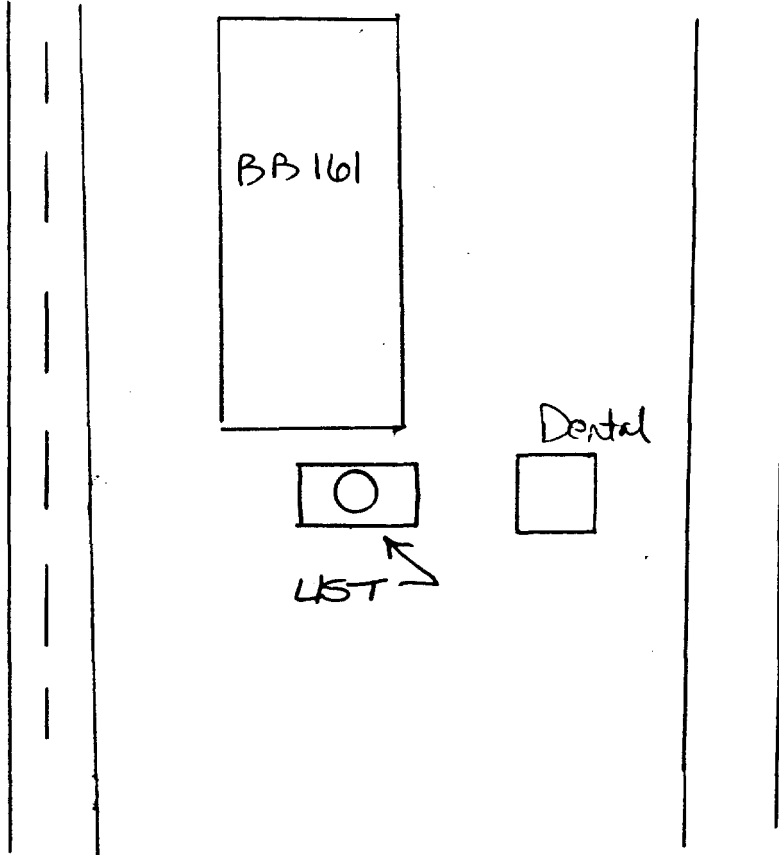



BB-190-Backwash  
BB-177-AST

12-10-93 B131  
Roll 9  
Photos 25; 26  
Rwm/Bm

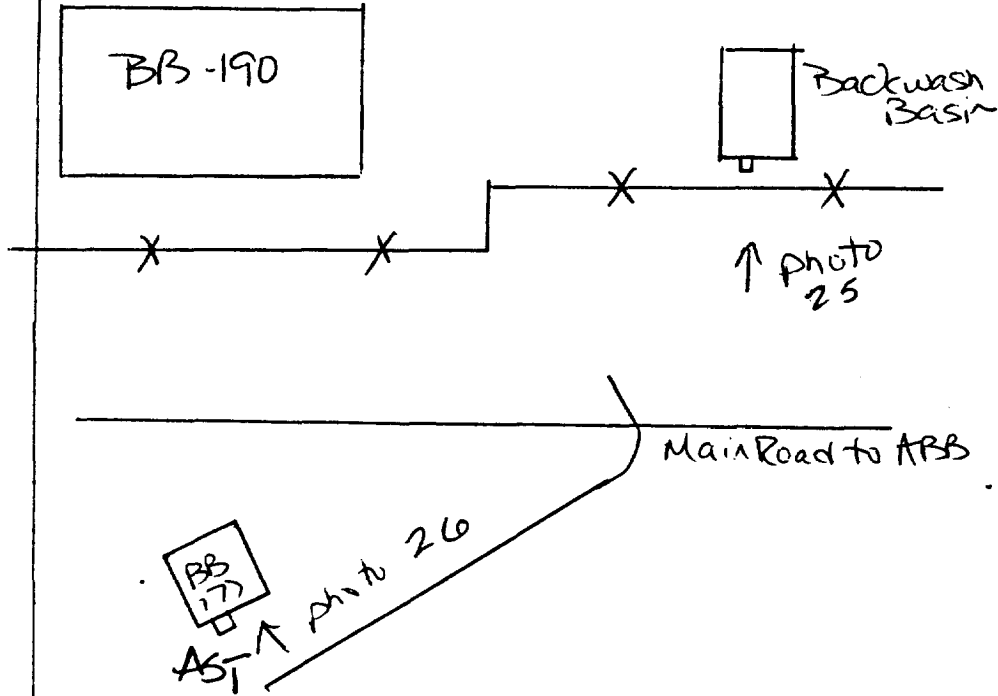

B-132



MALS-29

See pages 892, 93 & 95  
Rolls - Photos 14 & 15

Rwm/Bm  
"Duplicate"

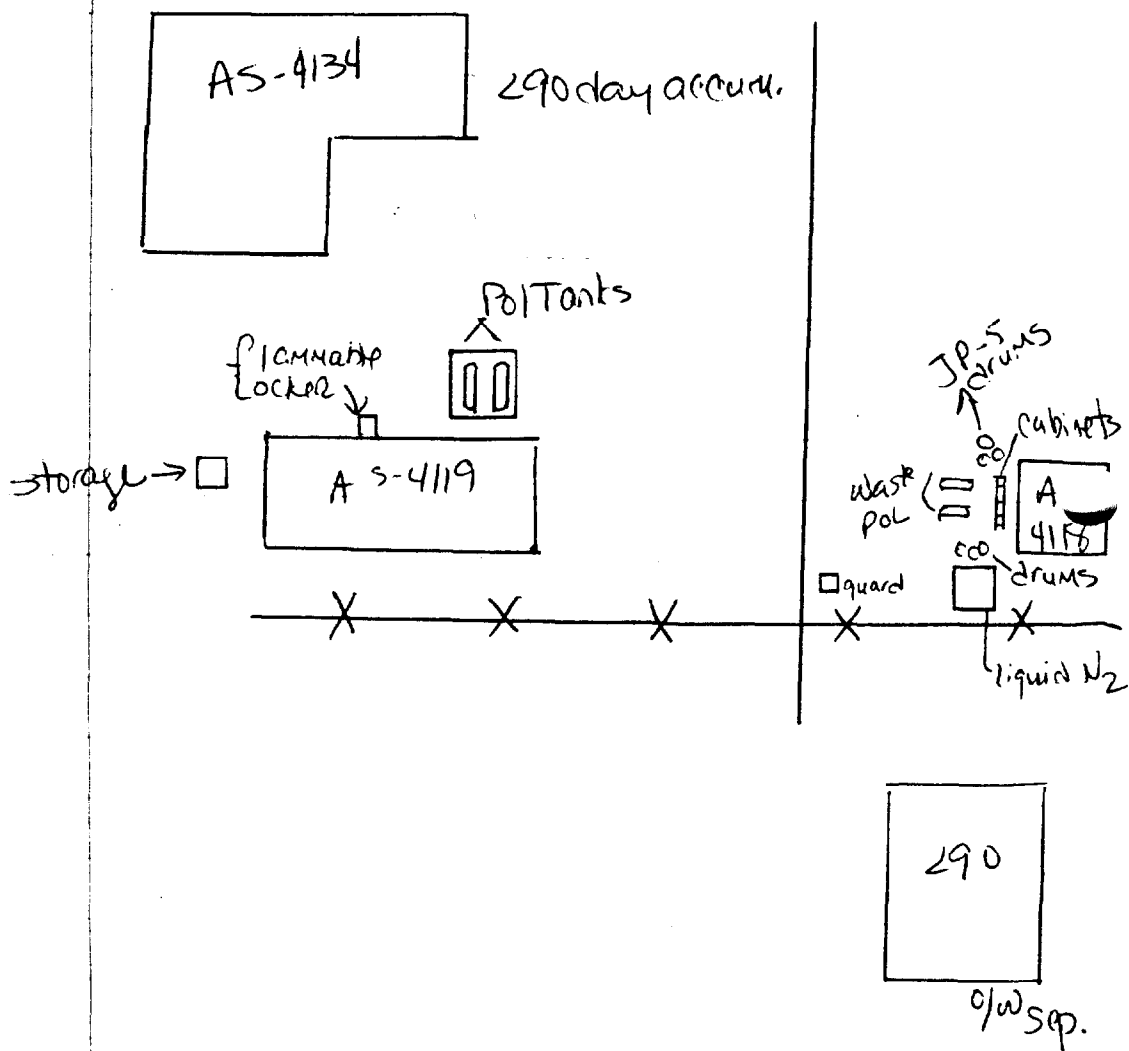

AS141-0/w  
MCAS AS141  
Fuel Farm

B-133  
12-09-93  
No Photo  
Rwm/Em

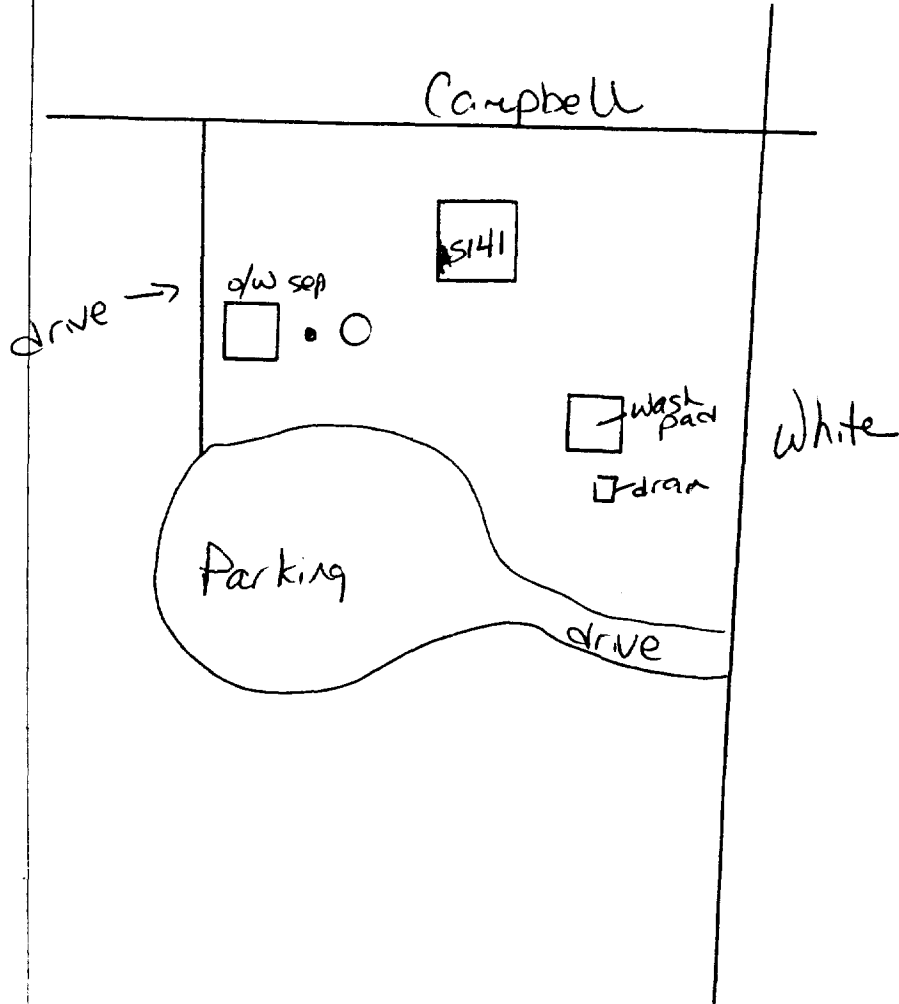

B-136

\*

12-09-93  
Duplicate Pump  
See Page B-86

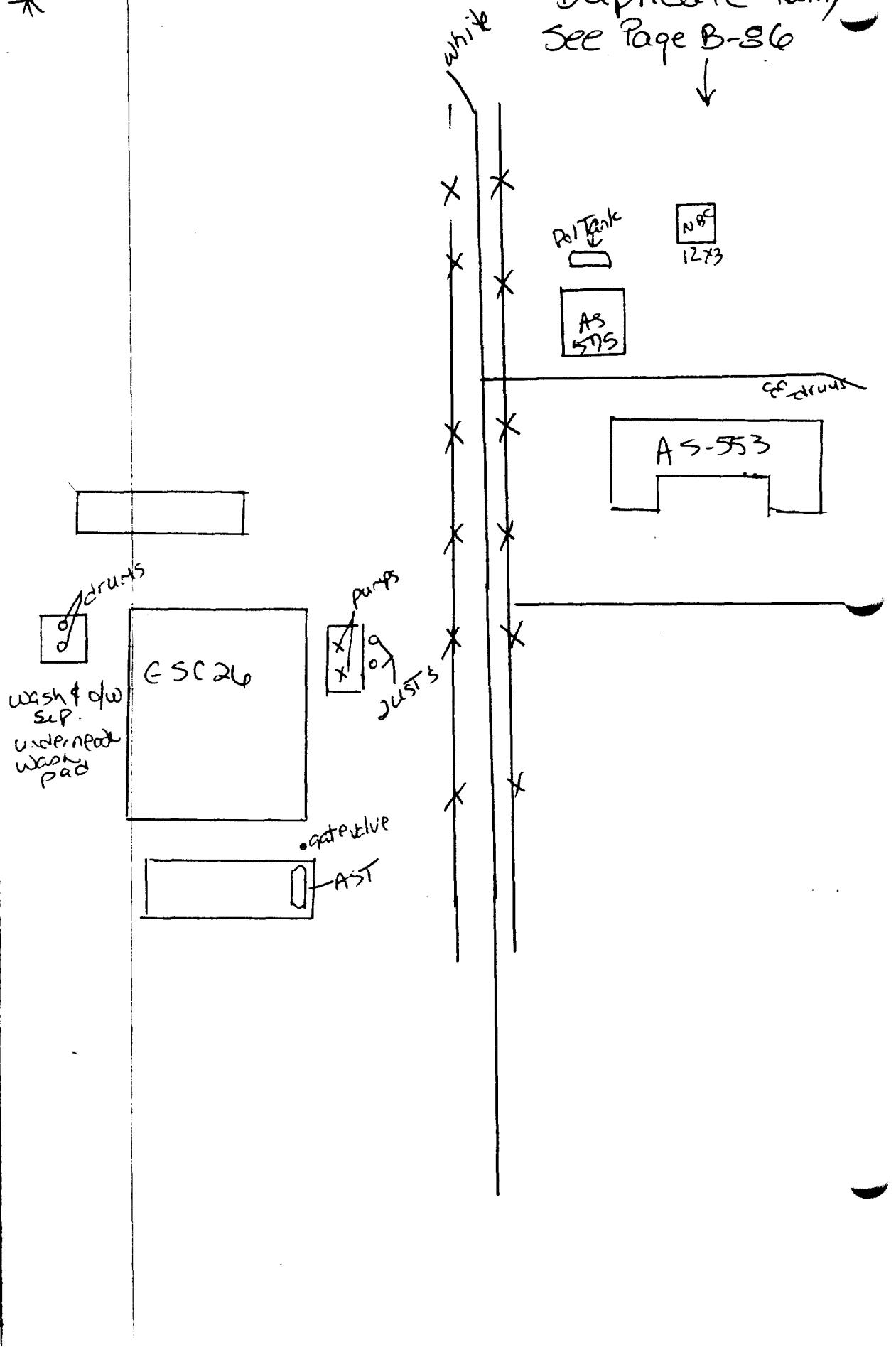

B135

12-09-93

See page B-102  
Rwm/Bm  
"Duplicate"

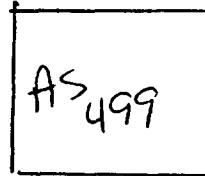
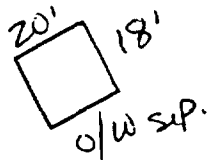
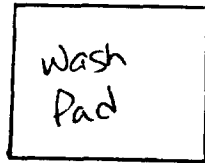

Runway  
↑  
↓

B-136

MCAS Fuel Farm

12-09-93

No Photo

Rwm/Bm

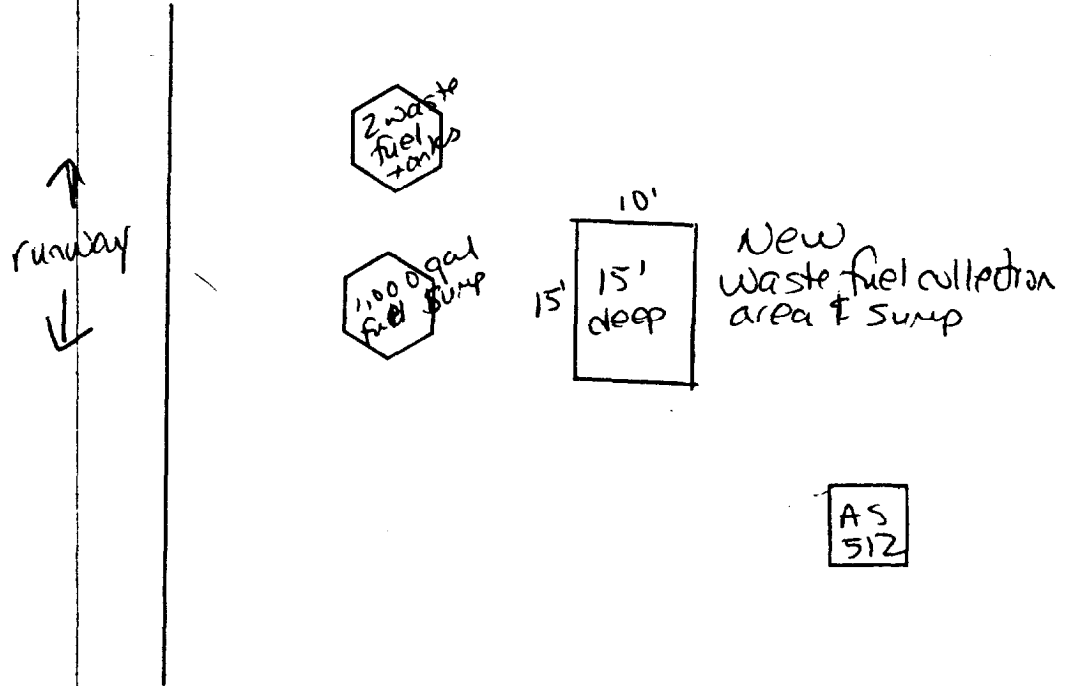

NOTE: No Photo since in Runway  
Could not find 2- oil/water separators.  
A new o/w was under construction  
2- waste fuel oil tanks were  
present.

B-137

See page B-111  
Rwm/Bm

12-09-93

"Duplicate"

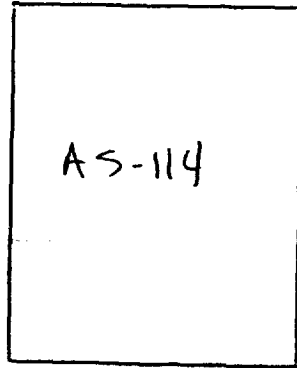

contaminated soil



used oil

drums



wash pad

ditch

B138

907-HWA

Roll 10 Photo 3  
cm

LOUIS STREET

To ~~S~~road Ferry

LOADING DOCK

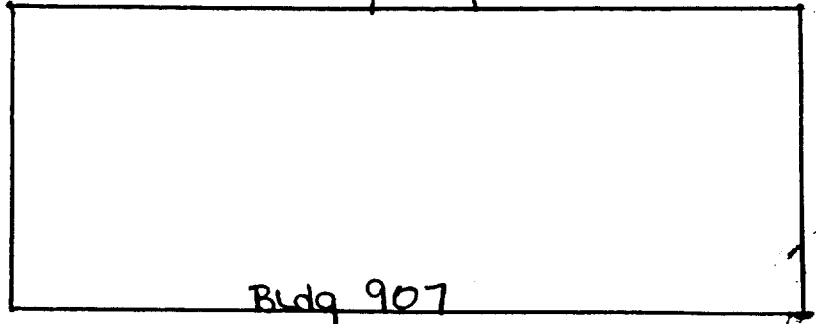

Bldg 907

FRANKLIN STREET



B-139

915 - HWA  
2nd FSSG

Roll 10 - PHOTO 5  
cm

FRANKLIN STREET

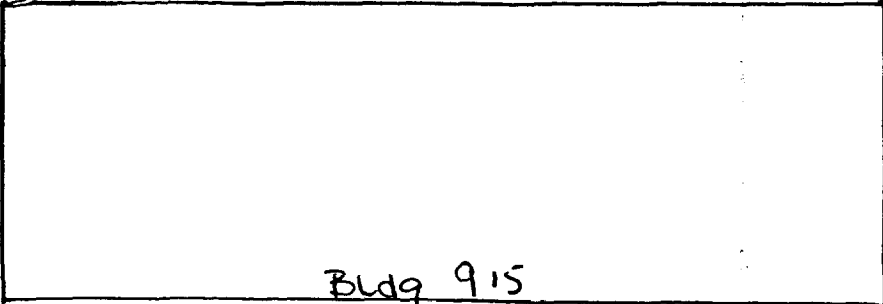

Bldg 915

"O" STREET

B-146 BF97-HWA-AST

Roll 10-Photo  
cm

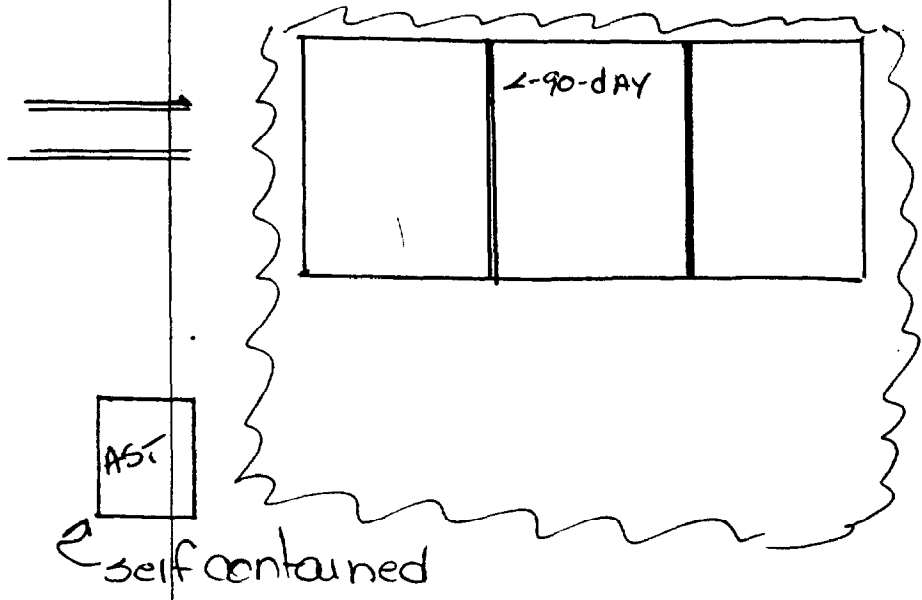

↑ photo

AS4117-HWA

3rd/1  
Roll 10 photo 8  
Cm

white street

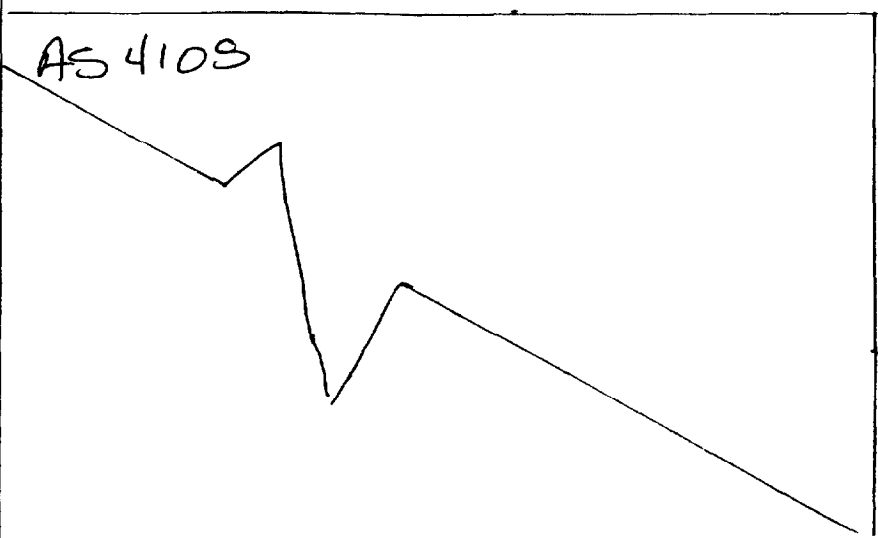
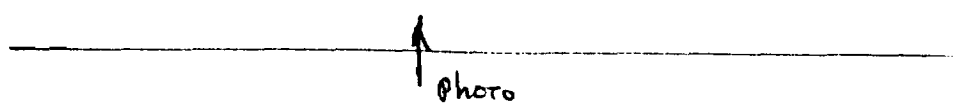
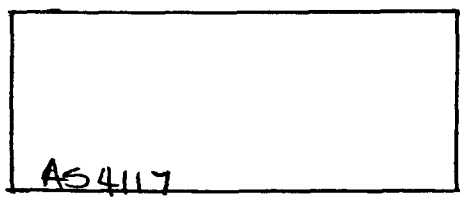

**APPENDIX D**  
**SITES BY UNIT TYPE**

**Table D-1**  
**< 90 Day H.W. Unit List**

Site Number	Page No.	Roll-Photo	Unit Name
A8-HWA	1	10-00	2nd Amphibious Assault Battalion, 2nd Marine Division
A47-HWA	2	1-2	2nd Amphibious Assault Battalion, 2nd Marine Division
SFC233-HWA	3	1-7	Supply Battalion, 2nd FSSG
SFC234-HWA	4	1-8	2nd Medical Battalion, 2nd FSSG
FC238-HWA	5	1-10	H&S Battalion, 2nd FSSG
SFC283-HWA	6	1-13	Maintenance Battalion, 2nd FSSG
SFC282-HWA	6	1-14	Maintenance Battalion, 2nd FSSG
FC285-HWA	8	1-17	Maintenance Battalion, 2nd FSSG
SFC37-HWA	9	1-18	Motor Transport, 2nd FSSG
SFC46-HWA	10	1-20	Operation Readiness Float, 2nd FSSG
FC51-HWA	11	1-22	Electronics Maintenance Company, 2nd FSSG
1601-HWA	12	1-23	Motor Transport Maintenance, 2nd FSSG
902-HWA	13	1-24/ 25	Engineer Maintenance Company, 2nd FSSG
SFC221-HWA	17	1-31	8th Engineers, 2nd FSSG
FC120-HWA	19	1-33	Land Support Battalion, 2nd FSSG
SFC145-HWA	19	1-35	Land Support Battalion, 2nd FSSG
FC134-HWA	20	1-37	Land Support Battalion, 2nd FSSG
SFC279-HWA	22	2-2	8th Motor Transport, 2nd FSSG
SM93-HWA	23	6-2	Marine Corps Support Services School Group
M144-HWA-AST	24	6-3	Marine Corps Support Services School Group
M90-HWA	25	6-4	Marine Corps Support Services School Group
1805-HWA	27	6-7	2nd Combat Engineer Battalion, 2nd Marine Division
1895-HWA-1	28	6-10	2nd Combat Engineer Battalion, 2nd Marine Division
1895-HWA-2	28	6-11	2nd Combat Engineer Battalion, 2nd Marine Division
1041-HWA	29	6-12	MCB Brig Company
1102/1131-HWA	32	2-5	MCB Maintenance
45-HWA	36	2-11	MCB Maintenance

**Table D-1**  
**< 90 Day H.W. Unit List**

Site Number	Page No.	Roll-Photo	Unit Name
1403-HWA	37	2-15	Training and Support Division
S1762-HWA	38	2-16	Morale, Welfare, and Recreation
TC773-HWA	39	2-18	School of Infantry
RR62-HWA	44	2-26	Rifle Range
M178-HWA	47	2-30	Field Medical Services
SFC235-HWA	49	3-3	8th Communication Battalion, 2nd SRIG
1605-HWA-1	50	3-4	8th Communication Battalion (Alpha Co-Radio), 2nd SRIG
1605-HWA-2	50	3-5	8th Communication Battalion (MagTaf), 2nd SRIG
1604-HWA	50	3-7	8th Communication Battalion, 2nd SRIG
1771-HWA	51	3-8	Headquarters & Service Company, 2nd Marine Expeditionary Forces
SFC237-HWA	52	3-9	2nd Anglico, 2nd SRIG
S1746-HWA	53	3-16	2nd Unmanned Aerial Vehicle, 2nd SRIG
FC365-HWA	54	3-13	2nd Radio Battalion, 2nd SRIG
SFC236-HWA	55	3-15	2nd Radio Battalion (Motor Transport), 2nd SRIG
1827-HWA-1	56	3-17	Intelligence Company 2nd SRIG
1827-HWA-2	56	3-18	Intelligence Company, 2nd SRIG
S1892-HWA	60	3-24	Communication Company, Headquarters Battalion, 2D Marine Division
1780-HWA	61	3-25	Truck Company Maintenance, Headquarters Battalion, 2D Marine Division
S1836-HWA	69	4-9	6th Marines Regiment, 2nd Marine Division
1829-O/W-1	69	4-10	6th Marines Regiment, 2nd Marine Division
SFC284-HWA	71	4-15	Unknown
S1854-HWA	B002	5-1	2nd Tank Battalion, 2nd Marine Division
1205-HWA	B004	5-4	H&S Company, 2nd Marine Expeditionary Forces
H36-HWA	B005	5-5	Engineering Maintenance Section, 2nd Marine Expeditionary Forces
BB51-HWA	B008	5-8	MC Engineering School
SBB135-HWA	B011	5-11	MC Engineering School

**Table D-1**  
**< 90 Day H.W. Unit List**

Site Number	Page No.	Roll-Photo	Unit Name
HP100-HWA	B016	5-17/ 18	8th Marine Regiment, 2nd Marine Division
HP104-HWA	B017	None	Communication Center, 8th Marine Regiment, 2nd Marine Division
1450-HWA	B018	5-21	5/10th Artillery Battalion, 10th Marine Regiment, 2nd Marine Division
HP250-HWA	B026	5-30	2nd Marine Division
NH118-HWA	B029	5-33	Naval Hospital
908-HWA	B032	6-13	Logistic
1502-HWA	B036	6-18	Logistic
A1-HWA	B043	6-25	2nd Amphibious Assault Battalion, 2nd Marine Division
TT2453-HWA	B046	6-29	MCB Auto Hobby Tarawa Terrace
BA130-HWA	B048	6-31	Motor T - 2nd Reconnaissance Battalion, 2nd Marine Division
575-HWA	B053	None	Motor T, 2nd Light Armory Infantry Battalion, 2nd Marine Division
1775-HWA	B070	7-21	1st/2nd/3rd BN-Maintenance, 10th Marine Regiment, 2nd Marine Division
1327/1343-HWA	B075	7-28	HQ Motor T, 10th Marine Regiment, 2nd Marine Division
AS431-HWA	B083	8-4	HMT 204/HMH 362, MAG-26, 2nd Marine Aircraft Wing
AS515-HWA-E	B086	8-7	HMM 266/ HMM 261, MAG-26, 2nd Marine Aircraft Wing
AS574-HWA	B087	8-8	HMM 261, MAG-26, 2nd Marine Aircraft Wing
AS525-HWA	B088	8-9	MALS 26 Maintenance, MAG-26, 2nd Marine Aircraft Wing
AS3905-HWA	B089	8-10	HMH 461/HMH 464, MAG-26/29, 2nd Marine Aircraft Wing
AS4112-HWA	B091	8-13	HMM 365, MAG-29, 2nd Marine Aircraft Wing
AS4134-HWA	B092	8-14	MALS 29 Maintenance, MAG-29, 2nd Marine Aircraft Wing
AS4114-HWA	B093	8-15	MALS 29 Maintenance, MAG-29, 2nd Marine Aircraft Wing
AS4115-HWA	B095	8-18	HMLA 167/HMM 263, MAG-26/29, 2nd Marine Aircraft Wing
AS4135-HWA	B096	10-9	MALS 29 GSE, MAG-29, 2nd Marine Aircraft Wing

**Table D-1**  
**< 90 Day H.W. Unit List**

<b>Site Number</b>	<b>Page No.</b>	<b>Roll-Photo</b>	<b>Unit Name</b>
AS4158-HWA	B105	8-29	MWSS272, MWSG-27, 2nd Marine Aircraft Wing
AS605-HWA	B113	9-1	MCAS < 90 Day H.W. Accumulation Area
907-HWA	B134	10-3	Medlog, 2nd Supply Battalion, 2nd FSSG
915-HWA	B135	10-5	2nd Supply Battalion, 2nd FSSG
SF97-HWA-AST	B136	10-6	MSSG-22, 2nd FSSG
AS4117-HWA	B137	10-8	HMM 162, MAG-29, 2nd Marine Aircraft Wing



**Table D-2  
Oil/Water Separator Unit List**

Site Number	Page No.	Roll-Photo	Unit Name
SA42-O/W	2	1-3	2nd Amphibious Assault Battalion
A47-0/W-1	2	1-4	2nd Amphibious Assault Battalion, 2nd Marine Division
A47-0/W-2	2	1-5	2nd Amphibious Assault Battalion, 2nd Marine Division
SFC268-O/W	3	1-6	Supply Battalion, 2nd FSSG
FC255-O/W	5	1-11	H&S Battalion, 2nd FSSG
FC280-O/W	6	1-15	Maintenance Battalion, 2nd FSSG
FC281-O/W	7	1-16	Maintenance Battalion, 2nd FSSG
FC40-O/W	9	1-19	Motor Transport, 2nd FSSG
FC45-O/W	10	1-21	Operation Readiness Float, 2nd FSSG
FC51-0/W	11	1-22	Electronics Maintenance Company, 2nd FSSG
816-O/W	14	1-26/ 27	8th Engineers, 2nd FSSG
GP190-O/W	15	1-28/ 29	8th Engineers, 2nd FSSG
739-O/W	16	1-30	8th Engineers, 2nd FSSG
FC200-O/W	18	1-32	8th Engineers, 2nd FSSG
FC120-O/W	19	1-34	Land Support Battalion, 2nd FSSG
FC134-O/W	20	1-36	Land Support Battalion, 2nd FSSG
FC270-O/W	21	2-1	8th Motor Transport, 2nd FSSG
M119-O/W	23	6-1	Marine Corps Support Services School Group
SM187-O/W	26	6-5/6	Marine Corps Support Services School Group
1859-O/W	27	6-8/9	2nd Combat Engineer Battalion, 2nd Marine Division
1203-O/W	30	2-3	MCB Maintenance
1105-O/W	31	2-4	MCB Maintenance
1700-O/W-1	33	2-6	MCB Maintenance
1700-O/W-2	33	2-7	MCB Maintenance
S1735-O/W	34	2-8/9	MCB Maintenance
738-O/W	35	2-10	MCB Maintenance
S792-O/W	36	2-13	MCB Maintenance
TC773-O/W	39	2-17	School of Infantry

**Table D-2  
Oil/Water Separator Unit List**

Site Number	Page No.	Roll-Photo	Unit Name
TC777-O/W	40	2-19	School of Infantry
G694-O/W-Rack	41	2-20/ 21/22	MCB Maintenance
M628-O/W	43	2-25	MCB Maintenance
SRR80-O/W	45	2-27	Rifle Range
RR15-O/W-1	46	2-28	MCB Maintenance
RR15-O/W-2	46	2-29	MCB Maintenance
FC230-O/W-1	48	10-0/1	8th Communication Battalion, 2nd SRIG
FC230-O/W-2	49	3-2	8th Communication Battalion, 2nd SRIG
S1619-O/W	50	3-6	8th Communication Battalion, 2nd SRIG
FC251-O/W	52	3-10	2nd Anglico, 2nd SRIG
1747-O/W-1	53	3-11	2nd Unmanned Aerial Vehicle, 2nd SRIG
1747-O/W-2	53	3-12	2nd Unmanned Aerial Vehicle, 2nd SRIG
SFC244-O/W	55	3-14	2nd Radio Battalion (Motor Transport), 2nd SRIG
SM632-O/W	57	3-19	Base Maintenance
M107-O/W-1	58	3-20	Motor Transport School Company.
M107-O/W-2	58	3-21	Motor Transport School Company.
1860-O/W	60	3-23	Communication Company, Headquarters Battalion, 2D Marine Division
1780-O/W-1	61	3-26	Truck Company Maintenance, Headquarters Battalion, 2D Marine Division
1780-O/W-2	61	3-27	Truck Company Maintenance, Headquarters Battalion, 2D Marine Division
1780-O/W-3	61	3-29	Truck Company Maintenance, Headquarters Battalion, 2D Marine Division
S1753-O/W-AST	62	None	Small Craft Company, Headquarters, 2D Marine Division
S1745-O/W	63	4-2	Truck Company Maintenance, Headquarters Battalion, 2D Marine Division
1601-O/W	66	4-5	Unknown
1829-O/W-1	69	4-10	6th Marines Regiment, 2nd Marine Division

**Table D-2  
Oil/Water Separator Unit List**

Site Number	Page No.	Roll-Photo	Unit Name
1829-O/W-2	69	4-11	6th Marines Regiment, 2nd Marine Division
P804-O/W-1	70	4-12	Unknown
P804-O/W-2	70	4-13	Unknown
FC285-O/W	71	4-14	Unknown
S1854-O/W-1	B001	5-2	2nd Tank Battalion, 2nd Marine Division
S1854-O/W-2	B001	5-3	2nd Tank Battalion, 2nd Marine Division
BB51-O/W	B006	5-6	MC Engineering School
BB150-O/W	B007	5-7	MC Engineering School
BB52-O/W-2	B010	5-10	MC Engineering School
SBB169-O/W	B012	5-12	MC Engineering School
SBB241-O/W	B013	5-14	MC Engineering School
BB293-O/W	B014	5-15	MC Engineering School
HP100-O/W	B015	5-16	Motor T, 8th Marine Regiment, 2nd Marine Division
1450-O/W-1	B019	5-22	5/10th Artillery Battalion, 10th Marine Regiment, 2nd Marine Division
1450-O/W-2	B020	5-23	5/10th Artillery Battalion, 10th Marine Regiment, 2nd Marine Division
BB9-O/W	B023	5-26	MCB Steam Plant
HP250-O/W	B025	5-29	2nd Marine Division
HP250-O/W-2	B027	5-31	32nd Communication, 2nd Marine Division
H118-O/W	B028	5-32	Naval Hospital
2615-O/W	B030	5-34	MCB O' Club
PT33-Pond-O/W	B031	5-35	MCB
961-O/W	B033	6-14	Logistic
1407/1408-O/W	B034	6-15	Logistic
1502-O/W-1	B035	6-16/ 17	Logistic
1502-O/W-2	B036	6-35	Logistic
AS118-O/W	B038	6-20 8-32	Logistic
AS22-O/W	B039	6-21	2nd Amphibious Assault Battalion, 2nd Marine Division
SA16-O/W	B041	6-23	2nd Amphibious Assault Battalion, 2nd Marine Division

**Table D-2  
Oil/Water Separator Unit List**

Site Number	Page No.	Roll-Photo	Unit Name
SA36 O/W	B042	6-24	2nd Amphibious Assault Battalion, 2nd Marine Division
BA130-O/W	B047	6-30	Motor T - 2nd Reconnaissance Battalion, 2nd Marine Division
1053-O/W	B049	6-32	Morale, Welfare, and Recreation Car Wash
S1132-O/W	B051	6-34	Unknown
1610-O/W	B052	6-36/ 37	MCB Auto Shop
575-O/W	B053	None	Motor T, 2nd Light Army Infantry Battalion, 2nd Marine Division
25-O/W	B057	7-4	MCB Dry Cleaners
S947-O/W	B062	7/10/ 11	MCB Recycling Center
1916-O/W	B068	7-20	MCB Golf Course
1775-O/W-UST	B071	7-22	1st/2nd/3rd BN-Maintenance, 10th Marine Regiment, 2nd Marine Division
1445-O/W	B073	7-26	Communication, 10th Marine Regiment, 2nd Marine Division
1343-O/W	B074	7-27	HQ Motor T, 10th Marine Regiment, 2nd Marine Division
1106/1107-O/W	B077	7-32	Motor T Auto Hobby
1205/1206-O/W	B078	7-33	Motor T, H&S Company, 2nd Marine Expeditionary Forces
1301/1309-O/W	B079	7-34	HQ & Service Company, 2nd SRIG
1405/1406-O/W	B080	8-2	Unknown
1505/1506-O/W	B082	8-0	Motor T
AS504-O/W	B084	8-5	HMT 204, MAG-26, 2nd Marine Aircraft Wing
AS3905-O/W	B090	8-12	HMH 461/HMH 464, MAG-26/29, 2nd Marine Aircraft Wing
AS4135-O/W	B096	10-10	MALS 29 GSE, MAG-29, 2nd Marine Aircraft Wing
AS515-O/W	B098	8-20/ 21	HMH 362, MAG-26, 2nd Marine Aircraft Wing
AS576-O/W	B099	8-22	HMM 365, MAG-29, 2nd Marine Aircraft Wing
AS-Pit-O/W	B100	None	MCAS
AS592-O/W	B101	8-24	MCAS Engine Test Cell, HMLA 269, MAG-29, 2nd Marine Aircraft Wing

**Table D-2  
Oil/Water Separator Unit List**

Site Number	Page No.	Roll-Photo	Unit Name
AS499-O/W	B102	8-25 9-11	MCAS
AS4159-O/W	B103	8-26	MWSS272, MWSG-27, 2nd Marine Aircraft Wing
AS4158-O/W	B104	8-28	MWSS272, MWSG-27, 2nd Marine Aircraft Wing
AS143-O/W	B106	8-30	MCAS Supply Dept.
AS123-O/W	B108	None	Morale, Welfare, and Recreation
AS605-O/W	B113	9-1	MCAS < 90 Day H.W. Accumulation Area
CG1-O/W	B114	9-2	MATCS-28, MACG-28, 2nd Marine Aircraft Wing
SAS3503-O/W	B118	9-8	MCAS
STC874-O/W	B123	9-13	MCAS DRMO
TC811-O/W	B124	9-16	MCB Security
SA45-O/W	B127	9-22	2nd. Amphibious Assault Battalion
AS141-O/W	B133	None	MCB

**Table D-3  
AST Unit List**

Site Number	Page No.	Roll-Photo	Unit Name
FC285-AST	8	1-17	Maintenance Battalion, 2nd FSSG
902-AST	13	1-24/ 25	8th Engineers, 2nd FSSG
M144-HWA-AST	24	6-3	Marine Corps Support Services School Group
1771-HWA-AST	51	3-8	Headquarters & Service Company, 2nd Marine Expeditionary Forces
FC241-AST	55	3-15	2nd Radio Battalion (Motor Transport), 2nd SRIG
M200-AST	59	10-7	Unknown
S1753-O/W-AST	62	10-2	Small Craft Company, Headquarters, 2D Marine Division
728-AST	64	4-3	Marina Gottschalk
1601-AST	65	4-4	2nd FSSG
1205-AST	B004	5-4	H&S Company, 2nd Marine Expeditionary Forces
H36-AST	B005	5-5	Engineering Maintenance Section, 2nd Marine Expeditionary Forces
BB51-AST	B009	5-9	MC Engineering School
SBB169-AST	B012	5-13	MC Engineering School
HP250-AST	B026	5-30	2nd Marine Division
TT2453-AST	B046	6-29	MCB Auto Hobby Tarawa Terrace
BA130-AST	B047	None	Motor T - 2nd Reconnaissance Battalion, 2nd Marine Division
575-AST	B053	None	Motor T, 2nd Light Armory Infantry Battalion, 2nd Marine Division
43-AST	B058	7-5	MCB Security
S946-AST	B063	7-12	MCB Recycling Center
913-AST	B065	7-15	MCB Recycling Center
TP45-AST	B066	7-18	MCB Truck Driving School
1106/1107-AST	B077	7-30	Motor T Auto Hobby
1301/1309-AST	B079	7-34	HQ & Service Company, 2nd SRIG
1612-AST	B081	None	Motor T
1505/1506-AST	B082	8-0	Unknown
AS431-AST	B083	8-4	HMT 204/HMH 362, MAG-26, 2nd Marine Aircraft Wing

**Table D-3  
AST Unit List**

Site Number	Page No.	Roll-Photo	Unit Name
AS504-AST	B085	8-6	HMH 362, MAG-26, 2nd Marine Aircraft Wing
AS574-AST	B087	8-8	HMM 261, MAG-26, 2nd Marine Aircraft Wing
AS525-AST	B088	8-9	MALS 26 Maintenance, MAG-26, 2nd Marine Aircraft Wing
AS3905-AST	B089	8-11	HMH 461/HMH 464, MAG-26/29, 2nd Marine Aircraft Wing
AS4112-AST	B091	None	HMM 365, MAG-29, 2nd Marine Aircraft Wing
AS4114-AST	B093	8-15	MALS 29 Maintenance, MAG-29, 2nd Marine Aircraft Wing
AS4108-AST	B094	8-16	HMLA 269, MAG-29, 2nd Marine Aircraft Wing
AS4115-AST	B095	8-17	HMLA 167/HMM 263, MAG-26/29, 2nd Marine Aircraft Wing
AS576-AST	B099	8-22	HMM 365, MAG-29, 2nd Marine Aircraft Wing
AS4159-AST	B103	8-27	MWSS272, MWSG-27, 2nd Marine Aircraft Wing
AS118-AST	B110	8-33	Motor T, MCB Logistic
AS114-AST	B111	8-34/ 35	MCAS Auto Hobby Shop
AS320-AST	B112	9-0	MCAS Flight Simulator
AS4158-AST	B115	9-4	MWSS272, MWSG-27, 2nd Marine Aircraft Wing
AS3504-AST	B118	None	MCAS AST
SAS3503-AST	B118	9-8	MCAS AST
45-AST-2	B129	9-21	MCB
BB177-AST	B131	9-26	Morale Welfare and Recreation
SF97-HWA-AST	B136	10-6	MSSG-22, 2nd FSSG

**Table D-4**  
**Basin/Backwash Unit List**

<b>Site Number</b>	<b>Page No.</b>	<b>Roll-Photo</b>	<b>Unit Name</b>
SLCH785-Basin	36	2-12	MCB Maintenance
SAS137-Basin	42	2-24	Marine Corps Air Station
SM269-Basin	59	3-22	Unknown
1700-Basin-B	67	4-7	Base Maintenance
AS415-Basin	72	2-23	MCB Maintenance
BB9-Basin	B023	5-27	MCB Steam Plant
TC364-Basin	B037	6-19	Logistic
S1001-Basin	B050	6-33	MCB Rail Head
540-Backwash	B055	7-2	MCB Pool
236-Backwash	B056	7-3	MCB Pool
BB190-Backwash	B131	9-25	MCB



**Table D-5  
UST Unit List**

Site Number	Page No.	Roll-Photo	Unit Name
1780-UST-1	61	3-26	Truck Company Maintenance, Headquarters Battalion, 2D Marine Division
1780-UST-2	61	3-28	Truck Company Maintenance, Headquarters Battalion, 2D Marine Division
S1854-UST-2	B003	None	2nd Tank Battalion, 2nd Marine Division
S1854-UST-1	B003	None	2nd Tank Battalion, 2nd Marine Division
HP100-UST	B015	5-19	Motor T, 8th Marine Regiment, 2nd Marine Division
NH118-UST	B029	None	Naval Hospital
575-UST	B053	None	Motor T, 2nd Light Armory Infantry Battalion, 2nd Marine Division
946-UST	B060	7-13	MCB Recycling Center
600-UST	B069	None	MCB Golf Course
1775-UST	B072	7-23/ 24/25	1st/2nd/3rd BN-Maintenance, 10th Marine Regiment, 2nd Marine Division
1323-UST	B076	7-29	HQ Battery-Motor T, 10th Marine Regiment, 2nd Marine Division
1106/1107-UST	B077	7-31	Motor T Auto Hobby
AS4135-UST	B096	8-19	MALS 29 GSE, MAG-29, 2nd. Marine Aircraft Wing
AS-Pit-UST	B100	8-23	MCAS
AS605-UST	B113	9-1	MCAS < 90 Day H.W. Accumulation Area
CG1-UST	B114	9-3	MATCS-28, MACG-28, 2nd Marine Aircraft Wing
BB161-UST	B130	9-23/ 24	MC Engineer. School

**Table D-6**  
**Wash/Grease Rack Unit List**

Site Number	Page No.	Roll-Photo	Unit Name
G694-O/W-Rack	41	2-20/ 21/22	MCB Maintenance
FC19-Rack	68	4-8	Unknown
H36-Rack	B005	None	Engineering Maintenance Section, 2nd Marine Expeditionary Forces
A1-Rack	B044	6-26	2nd Amphibious Assault Battalion, 2nd Marine Division
575-Rack	B054	None	Motor T, 2nd Light Armory Infantry Battalion, 2nd Marine Division
TP45-Rack	B067	7-19	MCB Truck Driving School
AS119-Rack	B107	8-31	MCAS Base Motor T
STC868-Rack	B123	9-14	MCAS DRMO
SM264-Rack	B125	9-17	Unknown
M105-Rack	B126	9-18	Unknown

**Table D-7  
Other Unit List**

Site Number	Page No.	Roll-Photo	Unit Name
Release (FC270)	22	None	8th Motor Transport, 2nd FSSG
TT2453-Release	B046	6-29	MCB Auto Hobby Tarawa Terrace
BB224-Pile	B022	5-25	Unknown
PT33-Pile	B031	5-36	MCB
AS22-Pile	B040	6-22	2nd Amphibious Assault Battalion, 2nd Marine Division
ST32-Pile	B045	6-28	MCB Maintenance
S947-Pile	B061	7-8/9	MCB Recycling Center
STC872-Pile	B123	9-15	MCAS DRMO
2611-Container	B024	5-28	MCB Parking Lot
1014-Container	B059	7-6/7	MCB Former PCB Storage Yard
S947-Container	B064	7-14	MCB Recycling Center
AS226-Still	B097	None	MCAS
034 Ditch	B021	5-24	5/10th Artillery Battalion, 10th Marine Regiment, 2nd Marine Division
AS-Curtis-Ditch	B116	9-6	MCAS Drainage Ditch Curtis Road
AS-Longstaff-Ditch	B117	9-7	MCAS Drainage Ditch longstaff Road
AS3003-Ditch	B119	9-9	MCAS Drainage Ditch
AS-Primington-Ditch	B120	9-10	MCAS Drainage Ditch Primington Road
AS5020-Ditch	B122	9-12	MCAS Drainage Ditch By Ordnance
1700-Pond-A	67	4-6	MCB Maintenance
PT33-Pond-O/W	B031	5-35	MCB
45-Pond	B128	9-19/ 20	MCB